

Installation, Commissioning and Servicing instruction manual

Floor Standing oil-fired Condensing Boiler using Conventional Flue & Room Sealed Flue

# Greenstar Danesmoor Utility Regular <sup>2022+</sup> & Utility System <sup>2022+</sup> 12/18, 18/25, & 25/32

For fully pumped open vent or sealed central heating systems and domestic hot water cylinders  
These appliances are for use with Kerosene (Class C2) only.

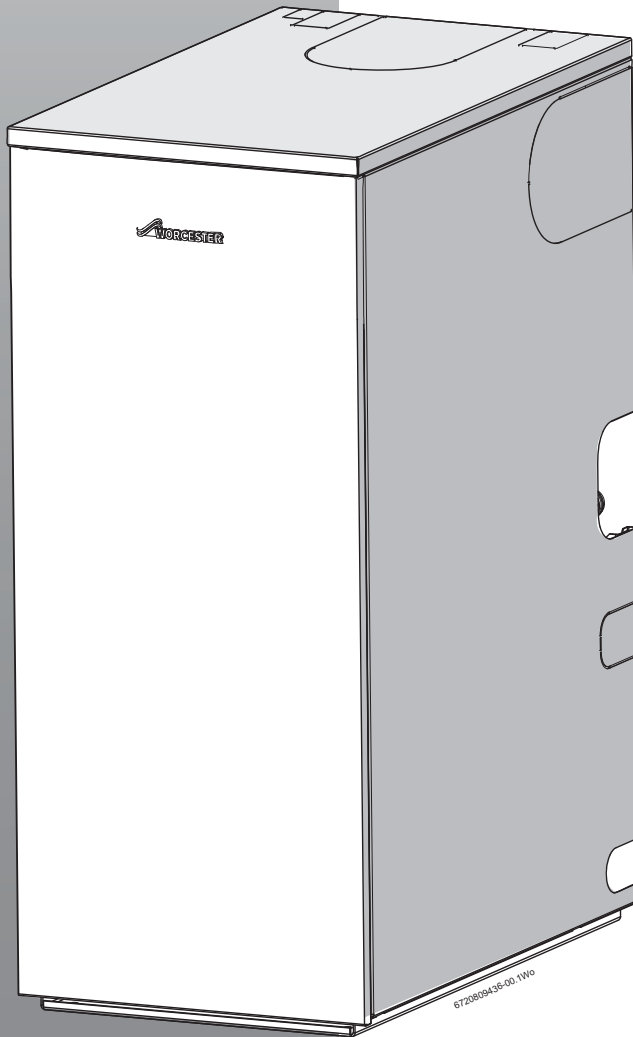

## Contents

<b>1</b>	<b>Key to symbols and safety instructions</b>	<b>3</b>		
1.1	Key to symbols	3		
1.2	General safety instructions	3		
<b>2</b>	<b>Installation regulations</b>	<b>5</b>		
2.1	Complying with the building regulations	5		
<b>3</b>	<b>Appliance information</b>	<b>6</b>		
3.1	General information	6		
3.2	Technical data	6		
3.3	Energy efficiency	7		
3.4	Layout and components			
	- 18/25 System appliance shown	8		
3.5	Layout and components			
	- 18/25 Regular appliance shown	10		
<b>4</b>	<b>Pre-Installation</b>	<b>11</b>		
4.1	Cleaning primary systems	11		
4.1.1	Before cleaning the system:	11		
4.1.2	Flushing the system	11		
4.1.3	Inhibitor	11		
4.1.4	Artificially softened water	11		
4.2	Mains supply	11		
4.2.1	Electrical supply	11		
4.3	Oil supply	12		
4.3.1	Single pipe gravity feed system:	12		
4.3.2	Double pipe sub-gravity feed system:	12		
4.3.3	Single pipe suction lift with de-aerator:	12		
4.3.4	Pipework	13		
4.3.5	Boiler isolation valve	13		
4.4	Water systems and pipework	13		
4.5	Condensate discharge	15		
4.5.1	Condensate pipe work	15		
4.5.2	Internal connections	15		
4.5.3	External connections	16		
4.6	Pressure relief pipework	17		
4.7	Boiler locations and clearances	17		
4.8	Flue gas system considerations	19		
4.8.1	Combustion air quality	19		
4.8.2	Flue terminal positions	19		
4.9	Flue options	22		
4.9.1	Conventional flue (CF)	22		
4.9.2	Room sealed flue options	23		
4.10	Plume management	24		
<b>5</b>	<b>Installation</b>	<b>26</b>		
5.1	Unpacking the boiler	26		
5.2	Pipework positions and flue opening	27		
5.3	Boiler installation	29		
5.4	Flue installation	29		
5.4.1	Flue damper installation	30		
5.4.2	Installation notes	30		
5.5	Combustion chamber (18/25 Regular shown)	31		
5.6	Pipework connections	32		
5.7	Oil burner and pump	33		
5.8	Refitting components	34		
5.9	Electrical	35		
<b>6</b>	<b>Commissioning</b>	<b>40</b>		
6.1	Pre-Commissioning checks - 18/25 Regular shown	40		
6.2	Filling the system	40		
6.3	Water treatment	41		
6.4	Starting the appliance	41		
6.4.1	Single pipe gravity feed system:	41		
6.4.2	Double pipe sub-gravity feed systems and single pipe suction lift with de-aerator:	41		
6.4.3	Pump adjustments	42		
6.4.4	Burner head setting	42		
6.4.5	Boiler lockout indicator on:	43		
6.4.6	Combustion checks	43		
6.4.7	Central heating	45		
6.5	Finishing commissioning	45		
6.5.1	Hand over	46		
6.5.2	Appliance guarantee	46		
<b>7</b>	<b>Service and Spares</b>	<b>47</b>		
7.1	Inspection and service - 18/25 Regular shown	47		
7.2	Pre-service checks	47		
7.3	Service requirements	48		
7.4	Sealed system only	48		
7.5	Clean the burner	48		
7.6	Oil burner nozzle	48		
7.7	Pump filter	49		
7.8	External oil filter	49		
7.9	Combustion chamber - 18/25 Regular shown	49		
7.10	Oil supply system and tank	50		
7.11	Clean the boiler - Manifold access	50		
7.12	Re-commissioning the burner	51		
7.13	After service hand over	52		
7.14	Spares	52		
<b>8</b>	<b>Fault finding and diagnosis</b>	<b>53</b>		
8.1	Burner functions	53		
8.2	Heating and hot water	54		
8.3	Boiler function	55		
8.4	Logic for the 535 SE/LD RDB control box	56		
8.5	Riello control box 12/18 model	57		
8.5.3	Fault finding	57		
8.5.4	Flame sensing photocell 12/18 models	59		
8.5.5	Flame sensing photocell 18/25 and 25/32 models	59		
8.6	Oil supply vacuum testing	59		
8.7	Air pressure switch and flue overheat reset	59		
8.8	Air pressure switch connections	59		
8.9	Oil appliance commissioning checklist	60		
8.10	Service interval record	61		

# 1 Key to symbols and safety instructions

## 1.1 Key to symbols

### Warnings

	<p>Warnings in this document are identified by a warning triangle printed against a grey background.</p> <p>Keywords at the start of a warning indicate the type and seriousness of the ensuing risk if measures to prevent the risk are not taken.</p>
---	---

The following keywords are defined and can be used in this document:

- **NOTICE** indicates a situation that could result in damage to property or equipment.
- **CAUTION** indicates a situation that could result in minor to medium injury.
- **WARNING** indicates a situation that could result in severe injury or death.
- **DANGER** indicates a situation that will result in severe injury or death.

### Important information

	<p>This symbol indicates important information where there is no risk to people or property.</p>
---	--

### Additional symbols

Symbol	Meaning
<b>1.</b>	a numbered step in an action sequence
▶	a step in an action sequence
→	a reference to a related part in the document or to other related documents
①	a reference number to identify or refer to a part or item
.	a list entry
-	a list entry (second level)

Table 1 Symbols

### Examples of additional symbols used

#### A numbered step in an action sequence

A sequence of numbered steps or actions carried out in a specific order to complete a task.

1. First action
2. Second action
3. Third action
- etc.

#### A step in an action sequence

A sequence of defined actions or steps carried out in order to complete a task.

- ▶ Action
- ▶ Next action
- ▶ etc

#### A reference to a related part in the document or to other related documents.

To refer the reader to a specific figure/table/section within the manual.

→ e.g. figure 1.

#### A reference number to identify or refer to a part or item.

In a related figure, items or parts identified by a sequential number.

### List entries, first and second levels

- A single component/item
- A component/list, made up of multiple parts/items.
  - Sub component or sublist of main component/list.
  - etc.

### Abbreviations used in this manual

∅	Diameter
CH	Central Heating
DHW	Domestic Hot Water
DCW	Domestic Cold water
HE	Heat Exchanger
TRV	Thermostatic Radiator Valve
IP	Ingress Protection
CF	Conventional Flue
RS	Room sealed
N/A	Not Allowed
SEDBUK	Seasonal Efficiency of Domestic Boilers in the UK
OFTEC	Oil Firing Technical Association for the Petroleum Industry
WRAS	Water Regulations Advisory Scheme
IET	Institute of Engineering and Technology
LABC	Local Authority Building Control Body
DWTA	Domestic Water Treatment Association

### Read these instructions before starting any installation

These instructions are applicable to the Worcester appliance model(s) stated on the front cover of this manual only and must not be used with any other make or model of appliance.

The instructions apply in the UK and Eire only and must be followed except for any statutory obligation.

This appliance must be installed by a competent person, failure to install correctly could lead to prosecution.

## 1.2 General safety instructions

These installation instructions are intended for heating engineers, plumbers, and electricians.

- ▶ Read any installation instructions (boiler, heating controls, etc.) carefully before starting the installation.
- ▶ Observe the safety instructions and warnings.
- ▶ Observe national and regional regulations, technical rules and guidelines.
- ▶ Record all work carried out.

### Oil fumes or leaks from the appliance

If you smell oil fumes, observe the following rules.

- ▶ Extinguish any naked flames
- ▶ Isolate the electrical supply
- ▶ Isolate the fuel supply to the boiler
- ▶ Open windows and doors
- ▶ Rectify the fault

### Health and safety

The appliance contains no asbestos and no substances have been used in the construction process that contravene the COSHH Regulations (Control of Substances Hazardous to Health Regulations). Where applicable, the CE mark indicates compliance with relative EU Directives.

### Combustible and corrosive materials

Do not store or use any combustible materials (paper, thinners, paints etc.) inside or within the vicinity of the appliance.

The combustion air must be kept clear of chemically aggressive substances which can corrode the appliance and invalidate any warranty.

### Handling instructions and guidelines

It is advised that more than one person is involved in the transfer of the packaged appliance from the van to the point of installation.

It is advised that no attempt should be made to move the packaged appliance without the use of a suitable truck.

At all times the correct method for handling heavy objects should be strictly observed.

- ▶ Lift only a manageable weight, or ask for help.
- ▶ When lifting, bend the knees, and keep the back straight and feet apart.
- ▶ Do not lift and twist at the same time.
- ▶ Lift and carry items close to the body.
- ▶ Wear protective clothing and gloves to protect from any sharp edges.

### Intended use

This boiler must only be used as a heat appliance in a heating system for domestic purposes.

Any other use is considered inappropriate. Any damage that results from such use is excluded from liability.

### Appliance operation

This appliance can be used by children aged from 8 years and above and persons with reduced physical, sensory or mental capabilities or lack of experience and knowledge, if they have been given supervision or instruction concerning the use of the appliance, in a safe way, and understand the hazards involved.

Children shall not play with the appliance.

Cleaning and user maintenance shall not be made by children without supervision.

### Installation, commissioning and servicing

Installation, commissioning and servicing must only be carried out by a competent registered engineer.

- ▶ Only use original spares.
- ▶ Advise the user to have the system regularly serviced by a competent, qualified engineer (such as OFTEC registered personnel) using approved spares, to help maintain the economy, safety and reliability of the appliance.

### Fitting and Modification

Fitting the appliance and any controls to the appliance may only be carried out by a competent engineer in accordance with these instructions and the relevant Installation Regulations.

Flue systems must not be modified in any way other than as described in the fitting instructions.

Any misuse or unauthorised modifications to the appliance, flue or associated components and systems could invalidate the warranty. The manufacturer accepts no liability arising from any such actions, excluding statutory rights.

### Electrical work

Electrical work must only be carried out by a qualified electrician.

- ▶ Before starting electrical work:
  - Isolate the mains electrical supply and secure against unintentional re-connection.
  - Check for zero potential.
- ▶ Also observe connection diagrams of other system components.

### Handover to the user

When handing over, instruct the user how to operate the heating system and inform them about its operating conditions.

- ▶ Explain how to operate the heating system and draw the user's attention to any safety-relevant action.
- ▶ Explain that modifications and repairs must only be carried out by an authorised contractor.
- ▶ Advise the user to have the system serviced annually by a competent, OFTEC registered engineer.
- ▶ Leave the installation instructions with the completed commissioning form and the operating instructions with the user.

## 2 Installation regulations

### 2.1 Complying with the building regulations

This heating appliance forms part of the controlled services for the building. It is law that all controlled services for buildings must comply with building regulations. You must be able to satisfy your Local Authority Building Control Body (LABC) that the work carried out concerning the installation and commissioning of this heating appliance has been carried out to a satisfactory standard.

OFTEC operate a competent persons scheme and registered installers are able to certify that their work complies with building regulations. Under the scheme;

- OFTEC must be informed about every installation.
- OFTEC will issue a building regulations compliance certificate to the householder and will notify the LABC.

OFTEC provide controlled document forms CD10 and CD11 for use during installation and commissioning respectively.

Other organisations operate self-certification schemes e.g. NAPIT and BESCA Ltd. and it may be possible for installers who are members of these organisations to self certify their work.

Alternatively you must submit a building control notice to the LABC before installing any boiler. The LABC will then arrange regular inspection visits during the work to ensure that the installation complies with the regulations.

#### Installation

Failure to install appliances correctly could lead to prosecution.

The appliance should be installed by a competent person. The person installing the appliance should be aware of the Health and Safety at Work Act and take appropriate action to ensure that the regulations are adhered to. In order to give optimum efficiency and trouble free operation the appliance must be commissioned by a qualified OFTEC engineer.

The compliance with a British Standard does not, in itself, confer immunity from legal obligations. In particular the installation of this appliance must be in accordance with the relevant requirements of the following British Standards and regulations in respect of the safe installation of equipment:

- BS 5410: part 1: Code of practice for Liquid Fuelled Boilers.
- BS 799: part 5: Specification for Oil Storage Tanks.
- BS 7593: Code of Practice for treatment of water in domestic hot water central heating systems.
- BS 5449: part 1: Specification for forced circulation hot water central heating for domestic premises.
- BS 5955: part 8: Specification for the installation of thermoplastic pipes and associated fittings for use in domestic hot and cold water services and heating systems.
- BS 7291: Thermoplastic pipes and associated fittings for hot and cold water for domestic purposes and heating installations in buildings.
- BS 7074: part 1: Application, selection and installation of expansion vessels and ancillary equipment for sealed water systems.
- BS 1254-2: Copper and copper alloys plumbing fittings part 2: Fittings with compression ends for use with copper tubes.
- BS 7671: IET Wiring Regulations, current edition.
- BS 1362: Specification for general purpose fuse links for domestic and similar purposes.

BS EN 12828 Heating systems in buildings. Design for water-based heating systems.

The Building Regulations Part G, Part J and L1 England and Wales; Part F, Part G and Part J Section III Scotland; Part L and Part F Northern Ireland.

Local water company bye-laws.

The Control of Pollution (Oil) Regulations.

OFTEC Standards.

Where no specific instruction is given, reference should be made to the relevant codes of practice.

#### Installations in Eire (Republic of Ireland)

The Installation must be performed by a competent and suitably trained person in accordance with the following Eire regulations.

Current Building Regulations - Republic of Ireland

ETCI rules for electrical installation

#### For further guidance see:

OFTEC Technical book three - Regional requirements: Republic of Ireland

### 3 Appliance information

#### 3.1 General information

##### Standard package:

- A - Floor standing oil fired condensing boiler
- B - Literature pack:
  - Greenstar Danesmoor Installation, Commissioning and Servicing instruction manual
  - User Instructions
  - Fascia information card
  - Guarantee registration card
- C - BSP plug, one inch (Regular only)
- D - ErP label
- E - Flue damper

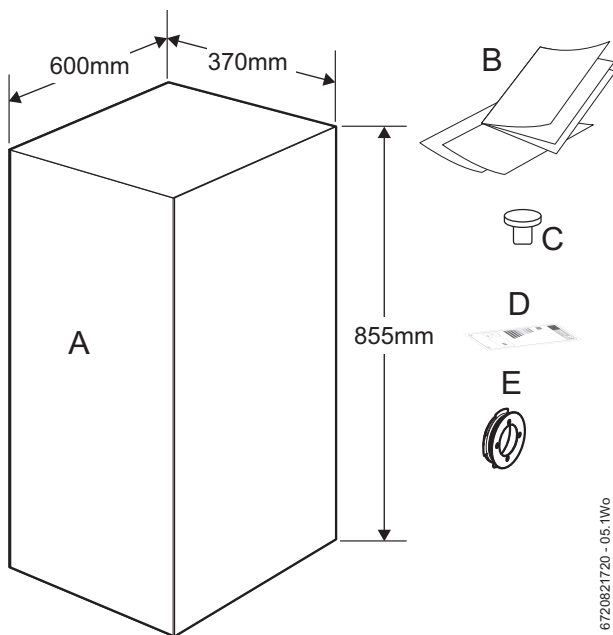

#### 3.2 Technical data

Description	Units	12/18	18/25	25/32
<b>Central heating</b>				
Central heat output (max)	kW	18	25	32
Primary water capacity (total)	litres	20	21	22
Maximum static head	metres	30	30	30
Minimum static head	metres	1	1	1
Water side resistance (20°C difference)	mbar	20	30	56
Maximum available pump head (20°C difference) Utility System	mH <sub>2</sub> O	5.2	4.3	4.1
Maximum permissible sealed system operating pressure in accordance with WRAS guidelines	bar	2.5	2.5	2.5
<b>Flue</b>				
Exit flue gas mass flow	kg/hr	29	40	51
<b>Pipework connections</b>				
Fuel line (compression)	mm	10	10	10
Flow Utility	BSP	1"	1"	1"
Flow Utility System	mm	22	22	28
Utility flow and optional vent/air vent	BSP	1	1	1
Return	mm	22	22	28
Condensate (Polypropylene)	mm	21.5	21.5	21.5
PRV outlet - Utility System	mm	15	15	15
<b>Electrical</b>				
Electrical power supply voltage	ac ..V	230	230	230
Frequency	Hz	50	50	50
<b>Thermostats</b>				
Boiler flow temperature range	°C	55/81	55/81	55/81
Control thermostat differential	°C	5	5	5
Boiler high limit thermostat set point	°C	95	95	95
Boiler manual reset overheat thermostat set point	°C	105	105	105
Flue manual reset overheat thermostat set point	°C	110	110	110
<b>General data</b>				
Maximum hearth temperature	°C	<100	<100	<100
SEDBUK 2009	%	90.7	90.6	90.5
SEDBUK 2005	%	93.0	92.9	92.7
Appliance protection rating	IP	20	20	20
Weight (excluding packaging) Utility Regular	kg	104	108	115
Weight (excluding packaging) Utility System	kg	112	112	122

### 3.3 Energy efficiency

The following product data satisfy the requirements of the EU Regulations No. 811/2013 and No. 812/2013 supplementing Directive 2010/30/EU.

Product data	Symbol	Unit	7731600245	7731600246	7731600247	7731600254	7731600255	7731600256
Product type	–	–	Danesmoor Utility Regular <sup>2022+</sup> 12/18	Danesmoor Utility Regular <sup>2022+</sup> 18/25	Danesmoor Utility Regular <sup>2022+</sup> 25/32	Danesmoor Utility System <sup>2022+</sup> 12/18	Danesmoor Utility System <sup>2022+</sup> 18/25	Danesmoor Utility System <sup>2022+</sup> 25/32
Condensing boiler	–	–	Yes	Yes	Yes	Yes	Yes	Yes
Low temperature boiler	–	–	No	No	No	No	No	No
B1 boiler	–	–	No	No	No	No	No	No
Cogeneration space heater (CHP)	–	–	No	No	No	No	No	No
Combination heater	–	–	No	No	No	No	No	No
Rated heat output	$P_{\text{rated}}$	kW	18	25	32	18	25	32
Seasonal space heating energy efficiency	$\eta_s$	%	92	92	92	92	92	92
Energy efficiency class	–	–	A	A	A	A	A	A
<b>Useful heat output</b>								
At rated heat output and high temperature regime <sup>1)</sup>	$P_4$	kW	18.2	25.1	32.9	18.2	25.1	32.9
At 30 % of rated heat output and low temperature regime <sup>2)</sup>	$P_1$	kW	5.6	7.8	10.0	5.6	7.8	10.0
<b>Useful efficiency</b>								
At rated heat output and high temperature regime <sup>1)</sup>	$\eta_4$	%	91.8	91.9	91.5	91.8	91.9	91.5
At 30 % of rated heat output and low temperature regime <sup>2)</sup>	$\eta_1$	%	98.5	97.8	97.3	98.5	97.8	97.3
<b>Auxiliary electricity consumption</b>								
At full load	$e_{\text{max}}$	kW	0.165	0.159	0.150	0.165	0.159	0.150
At part load	$e_{\text{min}}$	kW	0.053	0.049	0.047	0.053	0.049	0.047
In standby mode	$P_{\text{SB}}$	kW	0	0	0	0	0	0
<b>Other items</b>								
Standby heat loss	$P_{\text{stby}}$	kW	0.166	0.159	0.161	0.166	0.159	0.161
Ignition burner power consumption	$P_{\text{ign}}$	kW	-	-	-	-	-	-
Emissions of nitrogen oxides	NOx	mg/kWh	110	103	109	110	103	109
Annual energy consumption	$Q_{\text{HE}}$	GJ	57	78	103	57	78	103
Sound power level, indoors	$L_{\text{WA}}$	dB(A)	57	56	54	55	56	55

Table 2 Product data for energy consumption

- 1) High-temperature regime means 60 °C return temperature at heater inlet and 80 °C feed temperature at heater outlet.
- 2) Low temperature means for condensing boilers 30 °C, for low-temperature boilers 37 °C and for other heaters 50 °C return temperature (at heater inlet).

3.4 Layout and components - 18/25 System appliance shown

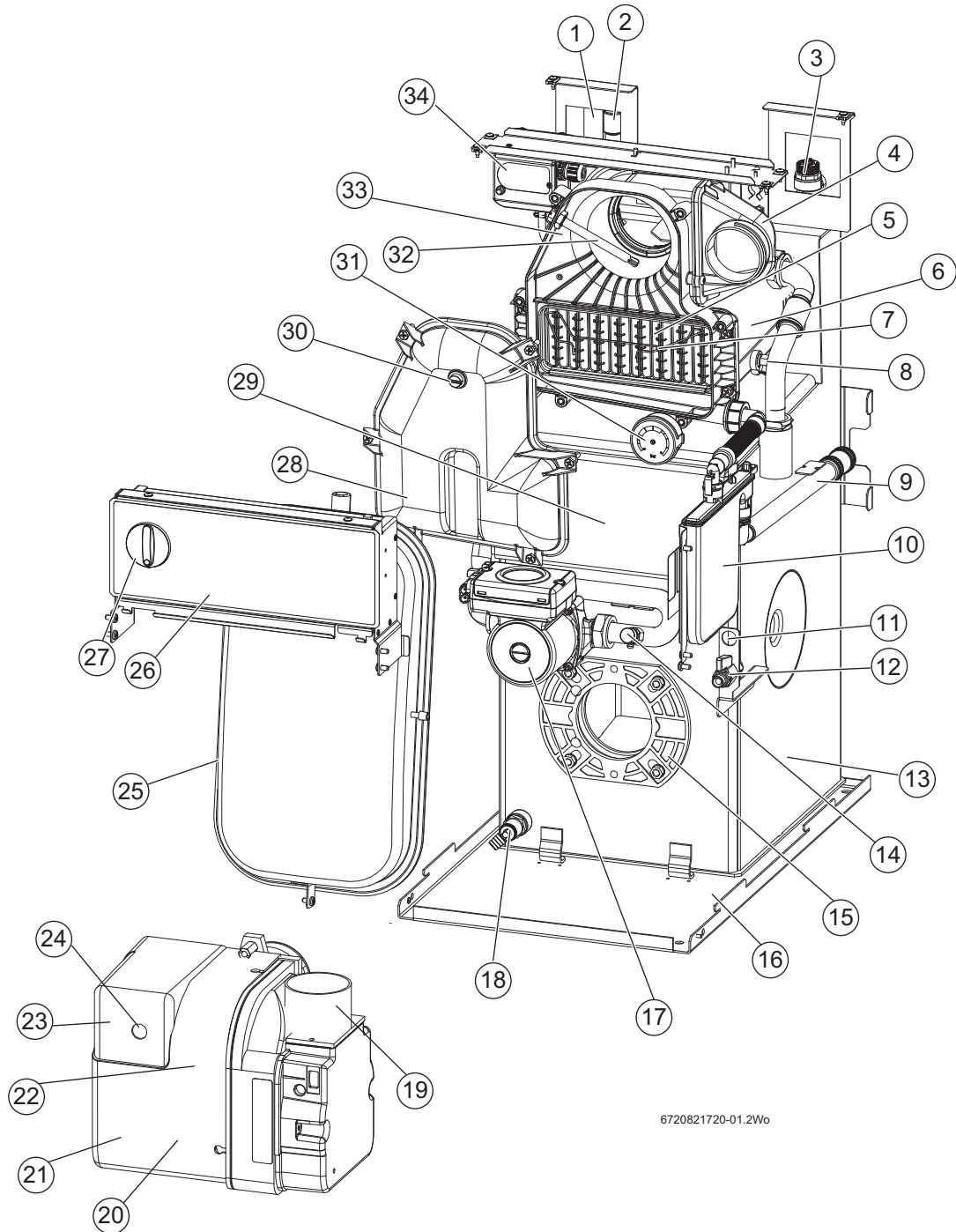

Fig. 1 System appliance shown

Figure 1 does not include the top, front, left, and right hand side panel			
1	Return connection	21	Oil pump (behind plastic cover)
2	Flow connection	22	Riello RDB burner
3	Pressure relief valve	23	Burner control box (behind plastic cover)
4	Air inlet casing	24	Lock out reset button (on the front of the burner control box)
5	Secondary heat exchanger baffles	25	Expansion vessel
6	Secondary heat exchanger	26	Control box assembly
7	Baffle retaining clip	27	Temperature control knob
8	Secondary Heat exchange drain point	28	Flue manifold access cover
9	Condensate discharge	29	Combustion chamber access door (primary baffle inside)
10	Condensate trap	30	Flue gas sampling point
11	Optional oil return position	31	System pressure gauge
12	Oil isolating valve	32	Flue overheat thermostat phial
13	Primary heat exchanger	33	Flue manifold
14	Pump drain point	34	Air pressure switch
15	Burner mount plate	35	Burner lead connector socket
16	Base plate and oil drip tray	36	Flue thermostat reset
17	Circulating pump	37	Expansion vessel retaining bracket
18	Primary heat exchanger drain point	38	High limit thermostat reset
19	Burner air intake	39	Auto reset thermostat
20	Burner motor (behind plastic cover)	40	Control & manual reset overheat thermostat phial
		41	Auto-reset high-limit thermostat phial

Table 3 Appliance component details

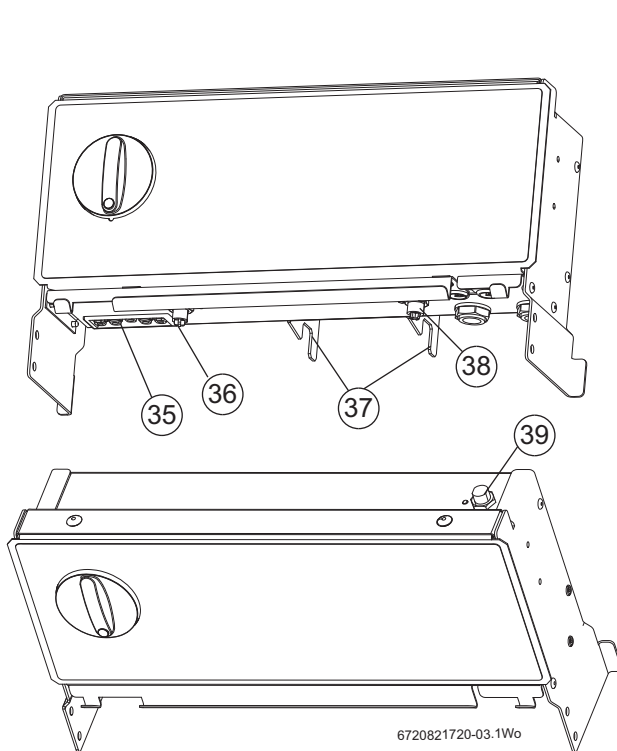

Fig. 2 Control panel thermostat detail

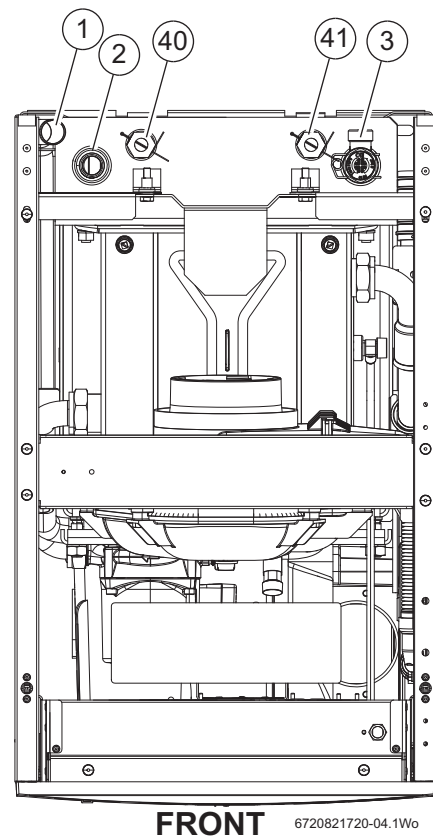

Fig. 3 Top view connections

### 3.5 Layout and components - 18/25 Regular appliance shown

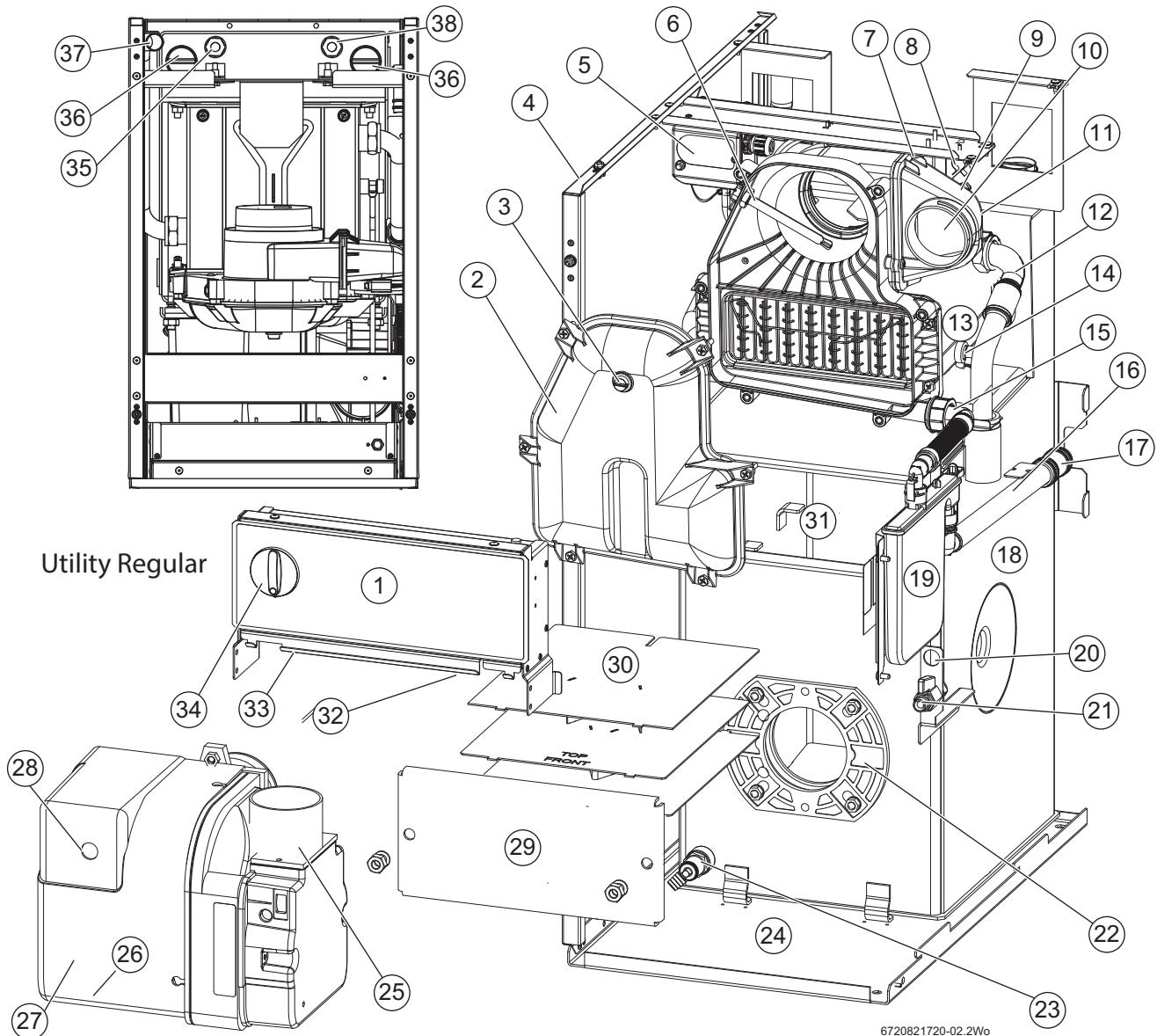



Fig. 4 18/25 Regular appliance shown

**Figure 4 does not include the top, front, and right hand side panel.**

1	Control box assembly	20	Optional oil return position
2	Flue manifold access cover	21	Oil isolating valve
3	Flue gas sampling point	22	Burner mounting plate
4	Casing side panel	23	Primary heat exchanger drain
5	Air pressure switch	24	Base plate and oil drip tray
6	Flue overheat thermostat phial	25	Burner air intake - connected by flexible duct [10] to air inlet casing [9]
7	Power cable clip	26	Burner motor - behind plastic cover
8	Fire valve sensor clip	27	Oil pump - behind plastic cover
9	Air inlet casing	28	Lockout reset button (on front of burner control box)
10	Flexible air duct (connecting to air intake [25] on burner)	29	Combustion chamber access door
11	Secondary heat exchanger bleed point (one on either side)	30	One piece baffle arrangement
12	Heat exchanger flow pipe	31	Combustion chamber
13	Secondary heat exchanger	32	Boiler overheat reset button
14	Secondary heat exchanger drain	33	Flue overheat reset button
15	Flexible condensate drain pipe connection	34	Temperature control knob
16	Condensate drain pipe	35	Control & manual reset overheat thermostat phial
17	Condensate outlet	36	Flow/Optional combined feed and vent
18	Primary heat exchanger	37	Return
19	Condensate trap	38	Auto-reset high-limit thermostat phial

## 4 Pre-Installation

### 4.1 Cleaning primary systems

 **DANGER:** Danger to life through electric shock!

- ▶ Before carrying out any work on electrical components, isolate them from the power supply (230 V AC) (fuse, circuit breaker) and secure against unintentional reconnection.

 **NOTICE:** Risk of damage to appliance or accessories!

- ▶ All the following pre-installation sections must be read and requirements met before starting the appliance or flue installations.

 **NOTICE:** Risk of damage to system or appliance!

Debris from the system can damage the appliance and reduce efficiency. Failure to comply with the guidelines for the use of water treatment with the appliance will invalidate the appliance guarantee and contravene the Building Regulations.

- ▶ It is a requirement of the Building Services Compliance Guide which is a second tier document to the Building Regulations to flush and inhibit the primary water system in accordance with BS 7593.
- ▶ It is recommended that you fit a primary water cleanser to the system. Worcester recommends fitting a filter that will help remove both magnetite and non-magnetic debris.

#### 4.1.1 Before cleaning the system:

- ▶ Ensure that the system and pipe work is in good working order.
- ▶ **Where possible keep the existing appliance/circulating pump in place when flushing the system.**

#### Follow the guidance of BS7593:

Treatment of water in domestic hot water central heating and also the flushing guidelines below.

#### 4.1.2 Flushing the system

- ▶ Fill the system with cold water and check for leaks.
- ▶ Open vented systems only:
  - Turn off the water to the system header tank.
- ▶ Open all drain cocks and drain the system.
- ▶ Close drain cocks and add a suitable flushing agent at the correct strength for the system conditions in accordance with the manufacturer's instructions.
- ▶ Circulate the flushing agent before the boiler is fired up.
- ▶ Run the boiler/system at normal operating temperature as directed by the manufacturer of the flushing agent.
- ▶ Drain and thoroughly flush the system to remove the flushing agent and debris.
- ▶ It may be necessary to use a power flushing machine to aid the cleansing procedure in some circumstances.
- ▶ Close the drain cocks and manual air vents.
- ▶ Add a suitable inhibitor to the system in accordance with the manufacturers instructions.
- ▶ Open vented systems only:
  - Turn on the water to the system header tank and allow the system to fill.
- ▶ Sealed systems only:
  - Fill the system to between 1 and 1.5 bar via a WRAS approved filling loop.
- ▶ Vent any air from the boiler and system.

#### 4.1.3 Inhibitor

Add a suitable inhibitor or combined inhibitor/anti-freeze, if the system is exposed to freezing conditions, to the heating system in accordance with the DWTA code of practice and manufacturer's guidelines.

 The inhibitor or combined inhibitor/anti-freeze must not cause damage to the materials within the boiler (mild steel, stainless steel, copper and brass) and any other materials/components within the system.

- ▶ The concentration level of inhibitor in the system should be checked every 12 months or sooner if system content is lost.

 **WARNING:** Sealing agents

- ▶ In cases where all attempts to find a system micro leak have failed, Worcester, Bosch Group supports the use of Fernox F4 leak sealer.

#### Water treatment products

Suitable water treatment products can be obtain from the following manufacturers:

ADEY	01242 546700 www.adey.com
FERNOX	0330 100 7750 www.fernox.com
SENTINEL	01928 704330 www.sentinelprotects.com/uk

#### 4.1.4 Artificially softened water

It is possible to have an ion exchange water softener fitted to the cold water system of the property. However, the boiler requires an untreated cold water connection taken from the mains supply, before the water softener, to the primary water filling point of the heating system. Alternatively there are water softening/treatment devices that do not adjust or alter the pH levels of the water. With these devices it may not be necessary to provide an untreated water by-pass to the primary water filling point of the heat system.

 **NOTICE:**

- ▶ Salt based, softened water must not be used to fill the central heating system.

## 4.2 Mains supply

### 4.2.1 Electrical supply

- Supply: 230V - 50 Hz
- Cable: PVC insulated 0.75 mm<sup>2</sup> (24 x 0.2mm) temperature rated to 90°C.
- External 5A fuse to BS1362.
- The appliance must be earthed.
- This appliance must not be connected to a three phase supply.
- Wiring must comply with the latest IET wiring regulations.
- It must be possible to isolate the appliance from the electrical supply with at least a 3mm contact separation in both poles supplying the appliance.
- Wiring between the appliance and the electrical supply must comply with IET wiring regulations and any local regulations that may apply for fixed wiring to a stationary appliance.
- Any additional components that are connected to the boiler with mains electrical supply must not have a separate supply.

### 4.3 Oil supply

**NOTICE:** Contaminated oil supplies can damage the appliance.  
Failure to ensure that the oil supply is clear of contaminants may invalidate the appliance warranty.

- ▶ Ensure the oil supply is free of contaminants and measures are taken to prevent contamination of the appliance.

**NOTICE:** Liquid fuel supply pipes should be provided with mains equipotential bonding in accordance with BS 7671.

- **This appliance is suitable for Kerosene (Class C2) only, no other fuel must be used.**
- Plastic or steel tanks should be installed to BS 5410. A steel tank should conform to BS 799: part 5 and have a slope of 1:24 away from the outlet with a sludge cock at the lower end.
- **Do not use galvanised steel tanks or pipework for the oil system.**
- **Do not use soldered joints on the oil supply pipework.**

**Key to Oil supply illustrations, figures 5, 6 & 7**

1	Oil storage tank
2	Full base (plastic tank)
3	Isolating valve
4	Oil strainer and water separator
5	Fire valve to BS 5410
6	External wall
7	Oil filter (70µm max filtration size)
8	Fire valve sensor
9	Oil pump
10	Oil burner
11	Non-return valve
12	De-aerator
13	Appliance isolation valve
14	Sleeve

Table 4 Key to oil supply feed system

#### 4.3.1 Single pipe gravity feed system:

The oil storage tank [1] must be positioned so that the oil level does not exceed 4 metres above the level of the burner oil pump [9] and in addition the oil level must be at least 300mm above the oil pump [9]. Where the maximum oil level in the oil storage tank exceeds 4 metres, a head breaking device must be installed between the tank [1] and the burner oil pump [9].

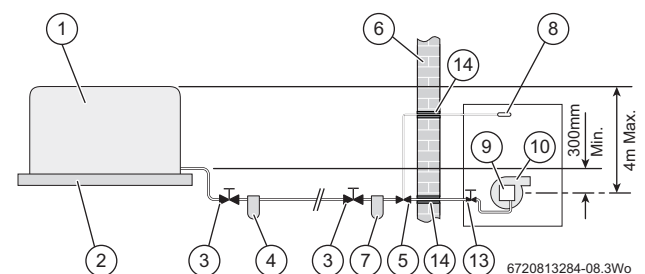

Fig. 5 Single pipe feed

**i** All dimensions are in metres unless otherwise stated. The maximum pipe run figures are based on using copper pipe with an inside diameter of 2mm less than the outside diameter.

#### Maximum pipe run for single pipe suction lift with de-aerator

#### Maximum pipe run for single pipe gravity fed system

Head (m)	10mmØ	12mmØ	Head (m)	10mmØ	12mmØ
0.5	12	30	2.5	62	100
1.0	25	69	3.0	74	100
1.5	37	91	3.5	87	100
2.0	49	100	4.0	99	100

#### 4.3.2 Double pipe sub-gravity feed system:

Maximum suction height 3.5 m. Non-return valves must be fitted to the inlet and return oil line between the oil pump [9] and oil storage tank [1].

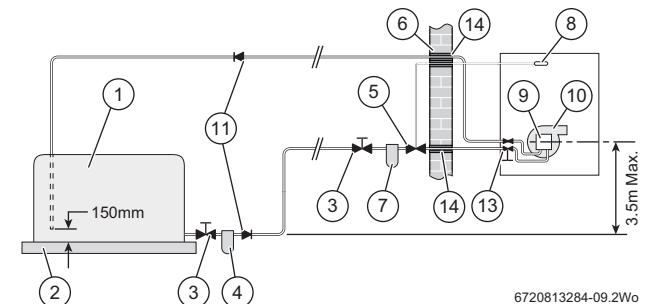

Fig. 6 Double pipe feed

#### Maximum pipe run for double pipe sub-gravity feed system

Head (m)	10mmØ	12mmØ	Head (m)	10mmØ	12mmØ
0	50	100	2.0	26	66
0.5	44	100	2.5	20	50
1.0	38	95	3.0	14	37
1.5	32	80	3.5	8	22

#### 4.3.3 Single pipe suction lift with de-aerator:

Maximum suction height 3.5 metres. The oil tank [1] must be positioned below the oil pump [9]. Create an inlet and return loop between the de-aerator [12] and oil pump [9].

A non-return valve must be incorporated within the de-aerator or fitted to the oil line between the oil storage tank [1] and the de-aerator [12].

A top feed oil tank fitted with a de-aerator using an internal non-return valve should have any non-return valves fitted in the base of the tank to the suction line removed to assist purging air from the oil line.

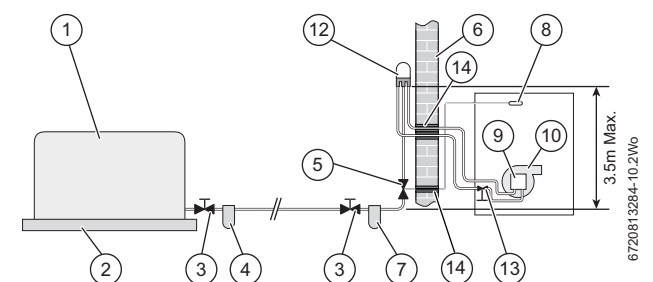

Fig. 7 De-aerator feed

Head (m)	FUEL FLOW RATE			
	2.5kg/h 8mmØ	5kg/h 8mmØ	10kg/h 8mmØ	10kg/h 10mmØ
0	100	55	26	100
0.5	95	45	23	100
1.0	80	40	20	90
1.5	70	35	17	75
2.0	60	30	14	65
2.5	45	25	11	50
3.0	35	15	8	35
3.5	25	10	5	20

[NOTE:] The table and illustration above is a guide only and does not in any way override the de-aerator manufacturer's instructions

#### 4.3.4 Pipework

- ▶ Refer to the oil supply sections Single pipe gravity feed system: 4.3.1, Double pipe sub-gravity feed system: 4.3.2 & Single pipe suction lift with de-aerator: 4.3.3 for oil supply pipework configurations.

Oil supply pipework considerations:

- Lay the oil supply pipe as straight and level as possible to avoid air pockets and unnecessary friction losses.
  - Route away from the boiler access door or other hot surfaces.
- Install a manual isolating valve to the oil supply pipe, as close to the oil storage tank as possible.
- Fit an oil strainer and water separator to the oil supply pipe, near the oil storage tank.
  - Fit an additional oil filter (70 µm max filtration size) close to the boiler, but not inside the boiler casing.
- Fit a fire valve in accordance with BS 5410.
  - The fire valve should be fitted externally to the building with the fire valve sensor located within the appliance case.
  - A fire valve with a shut off temperature of 85°C or higher must be fitted to avoid the possibility of nuisance shut offs.
  - A capillary type valve provides a neat and simple installation. Alternatively, a fusible link or electrical system may be used.
- Under no circumstances should a combination isolating/fire valve be used as the sole fire protection device.

#### 4.3.5 Boiler isolation valve

- ▶ Use copper pipe of the correct diameter according to the information shown in oil supply sections 4.3.1, 4.3.2 & 4.3.3.
  - If using soft copper pipe (R220) with a compression fitting, an insert must be used to prevent the pipe from collapsing or distorting when the fitting is tightened.
- ▶ Slide nut [1] and olive [5] onto the oil supply pipe [4].
- ▶ Slide insert [3] into the pipe.
- ▶ Offer the pipe to the fitting [2] and tighten the nut [1].

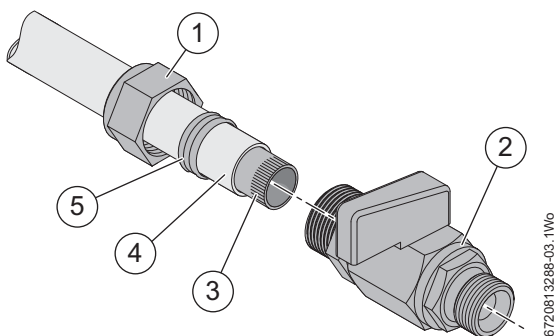

Fig. 8 Isolation valve bracket removed for clarity

- ▶ Use flexible hoses to connect to the oil pump.

## 4.4 Water systems and pipework

**NOTICE:**

▶ The boiler should not be allowed to operate with a return temperature of less than 30°C when the system is up to operating temperature.

- i** Oil burners cannot modulate to accommodate a reduction in heating loads. If the heating load can be significantly reduced due to TRV's or zoning of the heating circuits, consideration should be given as to how short cycling of the burner could be prevented. Burner run times should remain greater than 2 minutes during normal operation.
- A buffer vessel or thermal store should be considered to help prevent excessive short cycling of a single appliance, or a low loss header could be used to divide the heating duty between multiple lower output appliances.

#### Primary system plastic pipework:

- Any plastic pipework used for the CH system must have a polymeric barrier, complying with BS 7921 and installed to BS 5955 with 1000mm (minimum) length of copper or steel pipe connected to the boiler.
- Plastic pipework used for underfloor heating must be correctly controlled with a thermostatic blending valve limiting the temperature of the circuits to approximately 50°C with 1000mm (minimum) length of copper or steel pipe connected to the boiler, and a 20K differential must be maintained at the appliance.

#### Primary system/connections/valves:

- Do not use galvanised pipes or radiators.
- All system connections, taps and mixing valves must be capable of sustaining a pressure of 3 bar.
- Radiator valves should conform to BS 2767:10.
- All other valves should conform to BS 1010.
- An automatic bypass valve must be connected between the heating flow and return where TRVs are used on all radiators, fitted to give at least a 3 metre circuit when activated.
- Drain cocks are required at all the lowest points on the system.
- Air vents are required at all high points on the system.

#### Open vent primary system (Regular only)

- The open vent pipe (F) and feed and expansion pipe (H) must rise continuously from the appliance.
- The feed and expansion cistern (E) must be positioned to provide a static head (S) of at least 1 metre above the highest point in the heating system to the water level in the feed and expansion cistern.
- Ensure adequate space is left in the expansion cistern for expansion of the system water.
- No valve shall be fitted in the open vent pipe (F) or the feed and expansion pipe (H).
- The open vent pipe (F) must be at least 22mmØ.

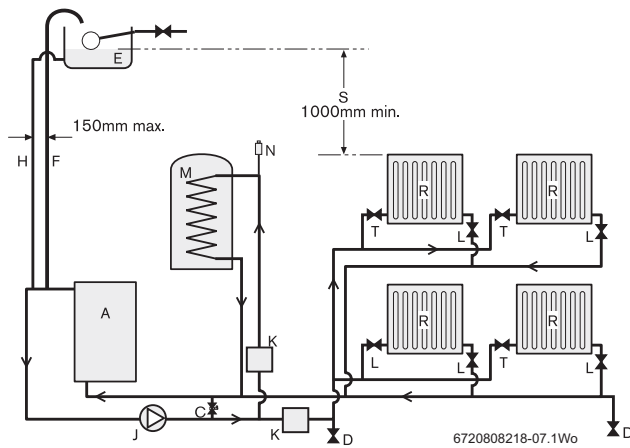

Fig. 9 Regular boiler, open vent layout

- [A] Regular appliance
- [A1] System appliance
- [B] Expansion vessel\*
- [C] Automatic bypass valve
- [D] Drain cock
- [E] Feed and expansion cistern
- [F] Open vent 22mmØ min.
- [G] Pressure gauge\*
- [H] Feed and expansion 15mmØ min.
- [J] Circulating pump\*
- [K] Zone valves
- [K1] Three port valve
- [L] Lockshield valve
- [M] Hot water cylinder
- [N] Automatic air vent
- [P] Pressure relief valve\*
- [P1] Pressure relief discharge\*
- [R] Radiators
- [T] Thermostatic radiator valve TRV
- [U] To filling system
- [NOTE] \* Components included in the System boiler

**Fully pumped sealed primary system:**

- A pressure relief valve (P), spring loaded safety valve set to operate at 3bar, must be fitted to the heating flow pipe as close as possible to the boiler or onto one of the boiler top 1" BSP outlets.
- An expansion vessel (B) must be fitted to the heating return pipe as close as possible to the boiler and pressurised for the system volume according to the instructions supplied with the vessel.
- A pressure gauge (G), 3 bar minimum, must be fitted to the heating flow pipe or one of the boiler 1" BSP outlets.
- An automatic air vent (N) must be fitted.

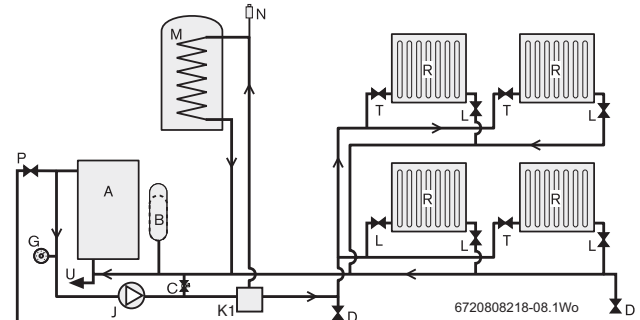

Fig. 10 Regular boiler, system layout

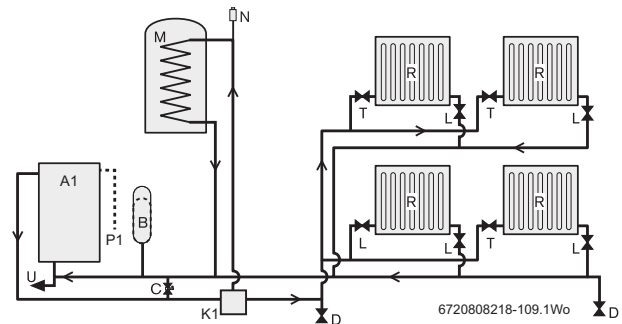

Fig. 11 System boiler system layout

**Filling primary sealed systems**

**NOTICE: FILLING THE SYSTEM**

▶ The system must not be filled with salt based softened water.

- Where the system volume is more than 180 litres at 0.5 bar or exceeds 2.65 bar at maximum heating temperature an extra expansion vessel (B) must be fitted as close as possible to the appliance in the central heating return.
- Pressurise the extra expansion vessel (B) to the same figure as the expansion vessel built into the appliance (system boilers).
- Filling the system must comply with one of the methods shown in the figure below.
- The filling point must be at low level and must never be a permanent connection to the mains water supply.
- Filling loops must be WRAS approved.

**SYSTEM FILL**

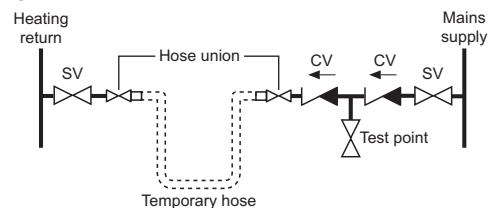

Fig. 12

- [SV] Stop valve
- [CV] Check valve

### 4.5 Condensate discharge

For correct installation and trouble free operation of the appliance the following advice should be followed:

1. All condensate pipework must 'fall' from the appliance by a minimum of 3 degrees (52mm per metre) to ensure adequate condensate flow.
2. The pipework route must allow air to be supplied back to the appliance for correct operation of the condensate trap.
3. Connection to a rainwater down pipe must include an air break.

Also:

- Keep external pipework as short as possible and not exceed 3 metres length.
- External pipework should be increased to a minimum diameter of 32mm and ideally be insulated.
- Minimise the number of bends and connectors.
- Remove burrs after cutting pipe.
- Remove surplus solvent from the interior of the pipe.

#### 4.5.1 Condensate pipe work



Follow **HHIC** guidance and recommendations for condensate disposal



**NOTICE:**

- ▶ Where a new or replacement boiler is being installed, access to an internal "gravity discharge" point should be one of the factors considered in determining boiler location.
- ▶ The condensate pipe must be nominally 21.5mm Ø polypropylene pipe.
- ▶ The condensate pipe work must fall at least 52mm per metre towards the outlet and should take the shortest practicable route.
- ▶ Ensure there are no blockages in the pipe run.



**NOTICE:** Unheated internal areas.

- The condensate discharge may freeze in areas during prolonged cold temperatures.
- ▶ Internal pipe runs in unheated areas such as lofts, basements and garages should be treated as external runs.

Key to condensate illustrations, figures 12, 13, 14 & 15

1	Condensate discharge from boiler
2	Soil and vent stack
3	Minimum 450mm and up to three storeys
4	Visible air break at plug hole
5	Sink or basin with integrated overflow
6	75mm sink waste trap
7	Condensate pump

Table 5 Key to Internal condensate disposal methods

#### 4.5.2 Internal connections

In order to minimise risk of freezing during prolonged cold spells, the following methods of installing condensate drainage pipe should be adopted, in order of priority.

Wherever possible, the condensate drainage pipe should be routed and terminated so that the condensate drains away from the boiler under gravity to a suitable internal foul water discharge point such as an internal soil and vent stack. A suitable permanent connection to the foul waste pipe should be used.

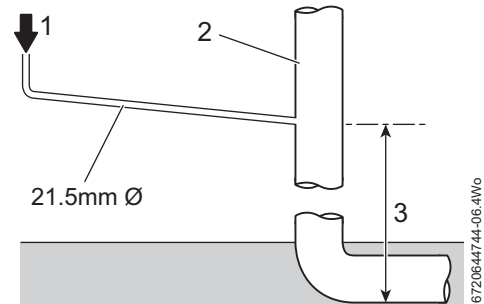

Fig. 13 Disposal to soil vent stack

Alternatively if the first option is not possible an internal kitchen, bathroom or washing machine waste pipe etc. can be used. Ensure that the condensate drain pipe is connected "down stream" of the waste trap.

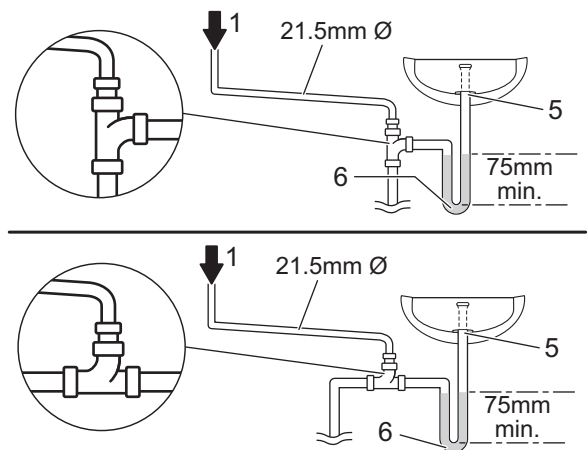

Fig. 14 Disposal to a waste pipe

#### CONDENSATE PUMP

Where "gravity discharge" to an internal termination is not physically possible, or where very long internal runs would be required to reach a suitable discharge point, condensate should be removed using a proprietary condensate pump, of a specification recommended by the boiler or condensate pump manufacturer.

The pump outlet pipe should discharge to a suitable internal foul water discharge point such as an internal soil and vent stack or if not possible to internal kitchen, bathroom or washing machine waste pipe etc. A suitable permanent connection to the foul waste pipe should be used.

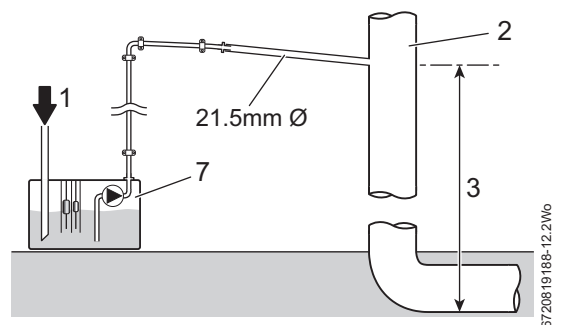

Fig. 15 Condensate pump disposal

**4.5.3 External connections**

**NOTICE:** Rainwater or external drain disposal  
Untreated condensate must not be allowed to flow into streams or rivers

- ▶ A rainwater down pipe or an external drain shall only be used for condensate disposal if the down pipe or external drain is connected to a combined foul and rainwater system
- ▶ Refer to BS 6798 for more information

**NOTICE:** Grey water systems  
Contamination of recovered water

- ▶ Condensate disposal shall not be allowed into a grey water recovery system that is intended for re-use

**NOTICE:** Freezing conditions

- ▶ Pipe work length should be kept to a minimum and the route as vertical as possible.
- ▶ When required, use only weather proof insulation.

**NOTICE:** Condensate waste

- ▶ Care should be taken when siting a soak-away to avoid obstructing existing services.

**Continued - Key to condensate illustrations, figures 13,14, 15 & 16**

8	Pipe work transition
9	Insulate and increase pipe size
10	External rain water pipe into foul water
11	External air break
12	Air gap
13	PVCu strap-on fitting
14	43mm 90 male/female bend
15	100mm Ø minimum plastic pipe
16	Drainage holes
17	Limestone chippings
18	Bottom of sealed tube
19	Increase size of soak-away with lime chippings if in clay soil

Table 6 Key to external condensate disposal methods

**i** Condensate drainage pipe can be run above or below ground. If the pipe work is run underground, care must be taken to ensure that the pipe work "fall" towards the disposal point is maintained

If no other discharge method is possible then the use of an externally run condensate drainage pipe terminating at a suitable foul water discharge point, or purpose-built soak away, may be considered. If this method is chosen then the following measures should be adopted:

- ▶ The external run be kept as short as possible and not exceed 3 metres.
- ▶ The pipe should be run internally as far as possible before going externally and the pipe diameter should be increased to 32mm before it passes through the wall to the exterior. The pipe should be insulated using suitable waterproof and weather resistant insulation, if not using a CondenseSure siphon.
- ▶ The external pipe should take the shortest and least exposed route to the discharge point, and should "fall" as steeply as possible away from the boiler, with no horizontal runs in which condensate might stand.
- ▶ The use of fittings, elbows etc. should be kept to a minimum and any internal "burrs" on cut pipe work should be removed so that the internal pipe section is as smooth as possible.

**FITTING AN EXTERNAL AIR BREAK**

- Refer to figure 16 when a rain water down pipe is used to dispose of condensate.
- An air break must be installed in the 43mm pipe work, between the boiler condensate outlet and the drainpipe, outside the property, to avoid flooding during adverse weather conditions.

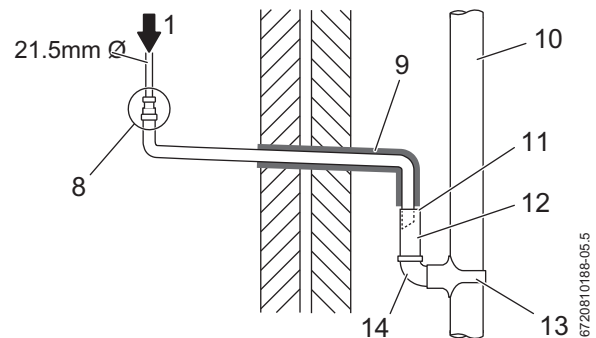

Fig. 16 Disposal into a rainwater down pipe

Where the pipe terminates over an open drain or gully, the pipe should terminate below the grating level, but above water level, in order to minimise "wind chill" at the open end.

The use of a drain cover (such as those used to prevent blockage by leaves) may offer further protection from wind chill.

Pipe drainage will be improved if the end is cut at 45° as opposed to a straight cut.

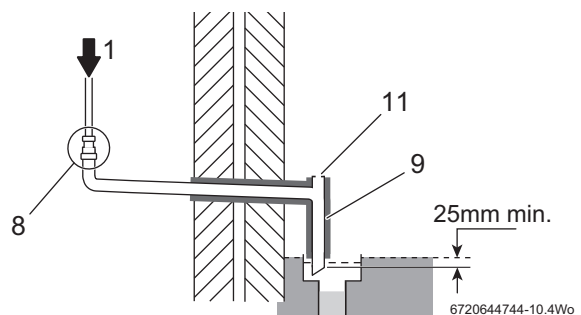

Fig. 17 External disposal

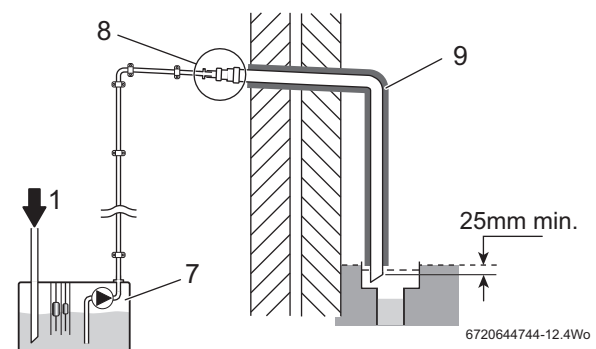

Fig. 18 Condensate pump to external disposal

**CONDENSATE SOAK AWAY**

- The condensate soak away must be sited at least 500mm away from building footings.
- The condensate drainage pipe may be run above or below the ground to the soak away. The examples shown on this page run above ground.
- The soak away must use a 100mm Ø plastic tube with two rows of three 12mm holes on 25mm centres and 50mm from the bottom of the tube. The holes must face away from the house.
- The tube must be surrounded by at least 100mm of limestone chippings to a depth of 400mm.



Minimum hole size for the condensate soak away must be 400mm deep by 300mmØ.

In situations where there are likely to be extremes of temperature or exposure, the use of a proprietary trace-heating system for external pipe work, incorporating an external frost thermostat, should be considered. If such a system is used, the requirement to use 32mm pipe does not apply. However, all other guidance above and the instructions for the trace heating system, should be closely followed.



**NOTICE:** Unheated internal areas.

- ▶ Internal pipe runs in unheated areas such as lofts, basements and garages should be treated as external runs and consideration should be given to using a CondenseSure siphon.

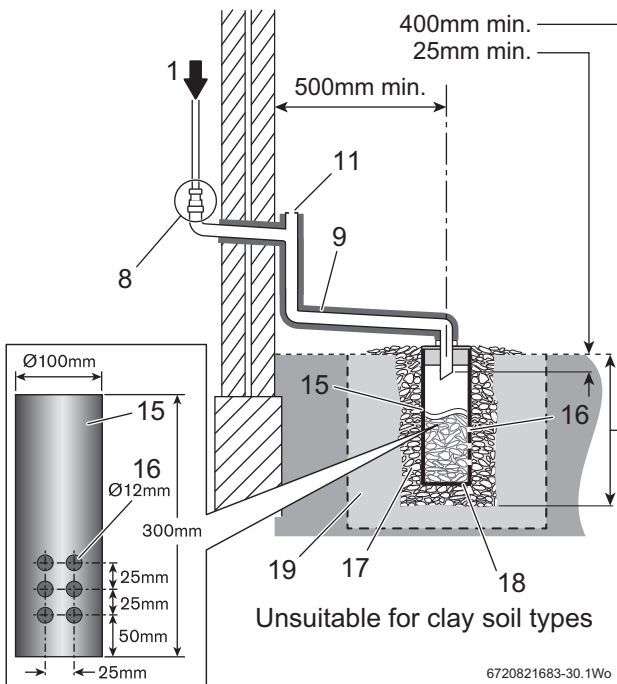

Fig. 19 To a soakaway

**4.6 Pressure relief pipework**

- The pressure relief discharge pipe (1) should be at least 15 mm diameter copper pipe and run downwards away from the boiler and discharge away from any electrical or other hazard, preferably to an external drain or soakaway.
- Pipe (3) should be finished with a partial bend, near the outlet to face the external wall (as shown) to help prevent freezing.

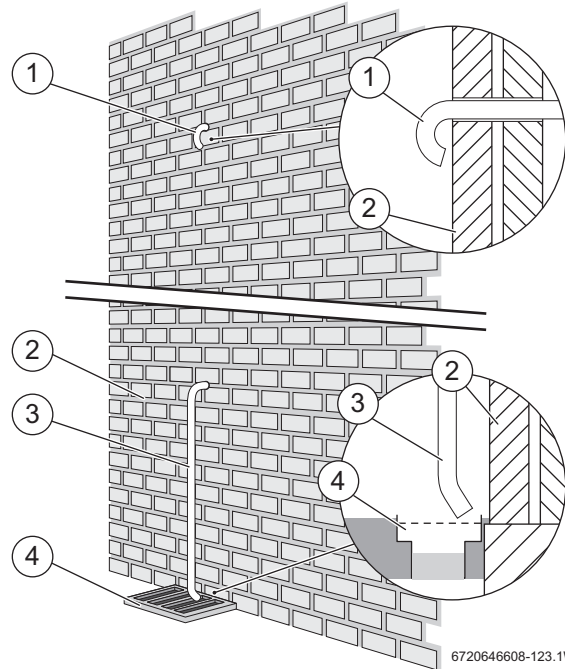

Fig. 20 Pressure relief pipe work

- [2] Outside wall
- [1, 3] PRV discharge pipe
- [4] External drain

**4.7 Boiler locations and clearances**



**WARNING:** Carbon Monoxide

- ▶ A carbon monoxide detector conforming to BS EN 50291-1 should be installed in accordance with the manufacturer's instructions.

This boiler is only suitable for installing internally within a property at a suitable location onto a fixed rigid surface of the same size as the boiler and capable of supporting the boiler weight.

The boiler must be installed on a flat level surface to ensure condensate does not enter the primary heat exchanger.

The boiler is not suitable for external installation unless a suitable enclosure is provided.

Roof space installations must fully conform to BS 5410 part 1 section 5.6.9.

**Open flue model (CF)**

In order to ensure clean and efficient combustion an adequate supply of air must be delivered to the combustion chamber.

To provide sufficient air a suitable inlet must be provided into the room or space in which the boiler is situated.

Output	12/18	18/25	25/32
Size cm <sup>2</sup>	99	138	165

An air brick or other form of continuous air supply may have to be built into the installation in order to ensure an adequate supply of air.

If the appliance is to be installed in a confined space or compartment two air vents are required, one at high level and one at low level.

The minimum free area of each vent is shown opposite and depends whether the air is taken from another room or from outside the building. Where the air is taken from another room that room must contain an air inlet as described above.

**Room sealed balanced flue models (RS)**

The appliance does not require a separate vent for combustion air. Installation in cupboards or compartments require permanent vents for cooling purposes, one at high level and one at low level, either direct to outside air or to a room. Both vents must pass to the same room or be on the same wall to the outside air.

The minimum air vent free area is given in the table opposite.

**Installation clearances**

Figure 21 shows the minimum space recommended to install the boiler only.

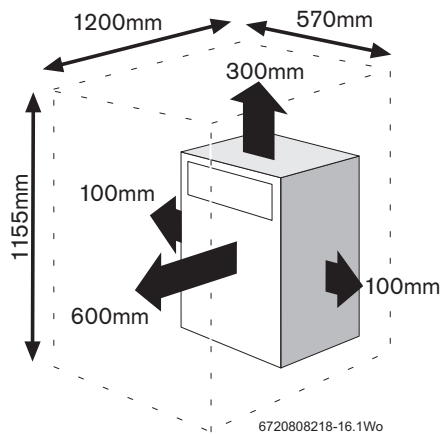

Fig. 21 Installation clearances

**Service clearances**

Figure 22 shows the minimum space required to carry out an annual service.

\* Remove the flue 'knock-out' panel sections if this clearance is less than 75mm.

The appliance is suitable for an under worktop installation providing that the worktop above the boiler (min 10mm clearance) is removable for maintenance and repair and the front of the boiler is not enclosed.

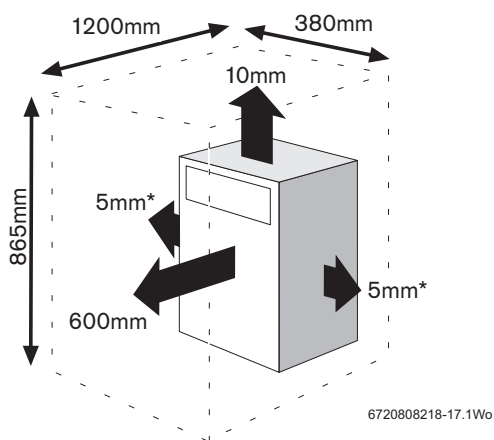

Fig. 22 Service clearances

**Maintenance clearances**

Figure 23 shows the clearances required for maintenance.

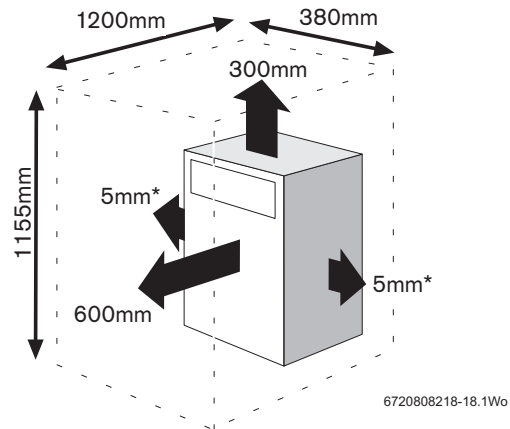

Fig. 23 Maintenance and repair clearances

**Minimum air vent area (cm<sup>3</sup>) for appliances installed in compartments**

Model	Internal ventilation		External ventilation	
	High level	Low level	High level	Low level
12/18	198	297	99	198
18/25	275	413	138	275
25/32	330	495	165	330

Table 7 Conventional flue

Model	Internal ventilation		External ventilation	
	High level	Low level	High level	Low level
12/18	198	198	99	99
18/25	275	275	138	138
25/32	330	330	165	165

Table 8 Room sealed flue

**Compartments**

Follow the requirements of BS 5410 and note:

- Minimum clearances must be maintained.
- An access door is required to install, service and maintain the boiler and any ancillary equipment.
- If fitting the boiler into an airing cupboard use a non-combustible material (if perforated, maximum hole sizes of 13mm) to separate the boiler from the airing space.

**Venting compartments**

There must be sufficient clearance around the appliance to allow proper circulation of ventilation air. The clearances required for installation and servicing will normally be adequate for ventilation.

- Ventilation must be provided for boilers fitted into compartments as described in BS 5410.
- Combustion air must not be taken from a room or internal space containing a bath or shower and must not communicate with a protected area such as a hall, stairway, landing, corridor, lobby, shaft, garage etc.
- Air vents must allow access for clean free air and must be sited to comply with the flue terminal position requirements.
- Air ducting runs must not exceed 3m.
- Low level air vents must be less than 450mm from the floor.
- A warning label must be added to the vents with a statement to the effect: "Do not block this vent. Do not use for storage."

**Rooms containing a bath or shower**

**WARNING:** Conventional flues

- ▶ Conventional flue boilers must not be installed in a bathroom

**WARNING:** Electric shock

- ▶ Any switch or appliance using mains electricity must not be within reach of a person using the bath or shower.

**i** In all cases the installation must be in accordance with the latest amendments in the latest edition of the IET wiring regulations (BS7671)

Refer to figure 24, the boiler must not be installed in zones 1 or 2. The boiler can be installed outside the shaded areas.

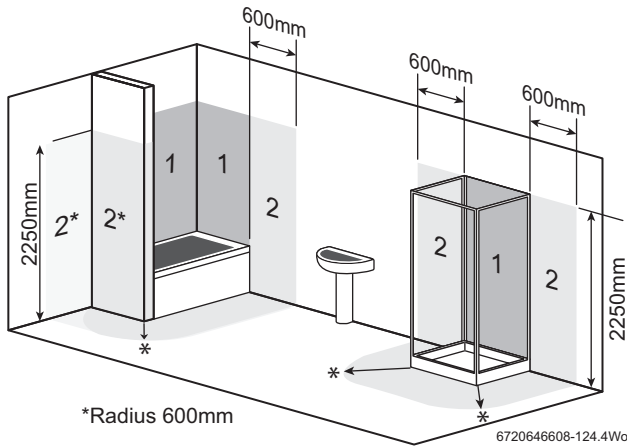

Fig. 24 Bathroom zones

- [2\*] Without end wall, zone 2 must extend 600mm from the bath
- [\*] 600mm radius from the bath or shower

**4.8 Flue gas system considerations**

**CAUTION:** Non accessible flue systems:

- ▶ Where a flue system is not going to be accessible, provision must be made for service and inspection.
- ▶ Flue gas system must comply with local standards and regulations.

**Room air dependant operation**

The boiler primarily operates as a “room air sealed” unit, however the boiler can be operated as a “room air dependant” unit, if required. Provide sufficient boiler room ventilation when operating the appliance room air dependent.

- ▶ Do not obstruct or block any ventilation openings.
- ▶ Ventilation openings must always be kept clear.

**4.8.1 Combustion air quality**

To avoid corrosion, combustion air must be free from aggressive substances (e.g. hydrogen halide, chlorines and fluorine).

**NOTICE:** Damage to appliance from contaminated combustion air and contaminated air in the vicinity of the appliance!

- ▶ Never operate the boiler in a dusty chemically aggressive environment i.e. spray painting, hair dressing and farming facilities.
- ▶ Never operate the boiler in places where using or storing trichlorethane, hydrogen halide and other aggressive chemical substances. These substances can be contained in spray cans, various glues, primers, paints and cleaning substances. In this case, the appliance must be connected in a room sealed configuration.

**4.8.2 Flue terminal positions**

**i** All measurements are the minimum clearances required

- Flue terminals must be positioned to avoid combustion products entering into buildings.
- The flue must be fitted and terminated in accordance with the recommendations of the latest version of BS 5410:1.
- The flue must not cause an obstruction.
- Discharge from the flue outlet must not cause a nuisance or dispute.
- Flue gases have a tendency to plume and in certain weather conditions a white plume of condensation will be discharged from the flue outlet which could be regarded as a nuisance, for example, near security lighting.
- There should be no restriction preventing the clearance of combustion products from the terminal.
- The air inlet/outlet duct and the terminal of the boiler must not be closer than 25mm to any combustible material. Detailed recommendations on protection of combustible materials are given in the latest version of BS 5410:1.
- Where a vertical flue terminates in an area that is enclosed on 3 sides, the flue must be no more than 1,000mm below the lowest roof line. You must ensure that all clearances are maintained and that products of combustion disperse safely from the area.
- Dimensions from a flue terminal to a fanned air inlet to be determined by the ventilation equipment manufacturer.
- A protective stainless steel terminal guard, must be fitted if the terminal is 2 metres or less, above a surface where people have access.
- See “Contact Information” on the back cover for flue guard information.

- Avoid discharging flue gases into car ports or narrow passageways.

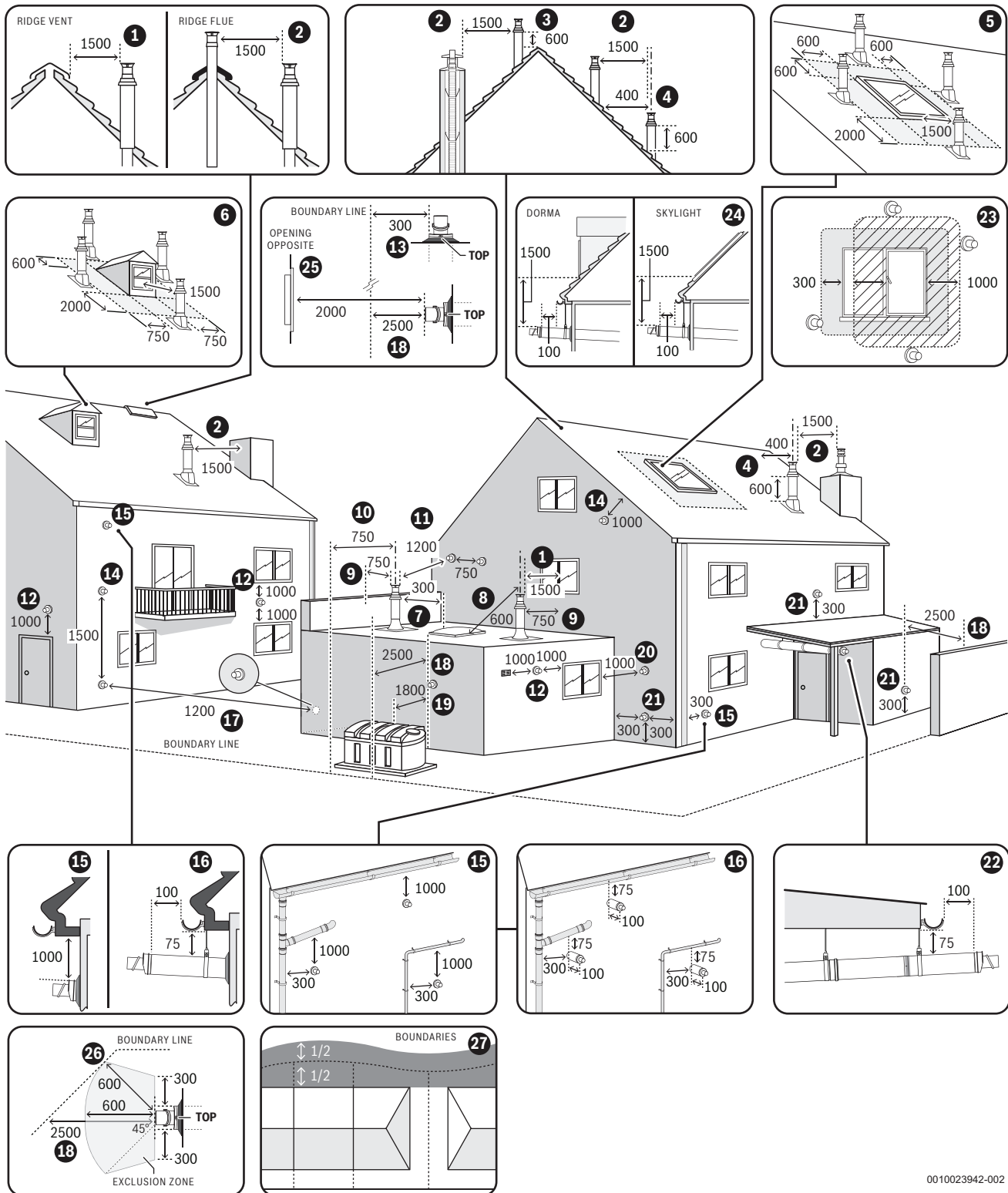

0010023942-002

Fig. 25 Flue terminal positions



**NOTICE:**

- ▶ All measurements are the minimum clearances required.
- ▶ Terminals must be positioned so to avoid combustion products entering the building.
- ▶ Support the flue at approximately one metre intervals and at a change of direction, use suitable brackets and fittings:  
- flue bracket 125mm x 1- Part No.: 7 716 191 179
- ▶ In spite of the dimensions given here, the terminal must not be closer than 300mm to combustible material, in the case of a thatched roof double this dimension.
- ▶ Terminals must be positioned so to avoid products of combustion accumulating in stagnant pockets around the building or entering the building.
- ▶ Terminals must be at least 1.8m from an oil storage tank unless a wall with of at least 30 minutes fire resistance and extending 300mm wider and higher than the tank is between the tank and the terminal.

**Key to illustration 25:**

1. 1,500mm measured between an opening or vented window and vertical flue terminal. This measurement can be reduced to 1000mm providing the flue terminal is at least 300mm above the opening.
2. Minimum clearance to an additional flue, 1,500mm between room sealed flues or room sealed flue and open flue, 1,000mm between open flues.
3. 600mm above a vertical structure less than 750mm from the side of the terminal.
4. The flue must extend at least 600mm above the intersection of the roof (flat and pitched) and be 400mm horizontally from a pitched roof or 500mm in regions with heavy snow fall
5. The flue must not penetrate the roof in the shaded area. The flue must be at least 2,000mm from the opening or vent when sited below the window, 600mm when sited to either side or above. The terminal must be at least 1,500mm room sealed, 1,000mm open flue from the opening or vent when measured horizontally.
6. The flue must not penetrate the roof in the shaded area. The flue must be at least 1,000mm from the opening or vent when sited below the window, 750mm when sited to either side and 300mm above. The terminal must be at least 1,500mm room sealed, 1,000mm open flue from the opening or vent when measured horizontally.
7. 300mm minimum clearance measured from a non opening skylight to a vertical flue. Vertical flue clearance,
8. 600mm minimum clearance measured from an opening or vented skylight to a vertical flue. If the terminal is within 1,500mm of the opening or vented skylight then it must be at least 600mm above the opening.
9. 750mm clearance to a structure from a vertical flue.  
Not required if the terminal is 600mm above the structure.
10. 750mm adjacent to a boundary line unless it will cause a nuisance. BS 5410: Part 1 recommended that care is taken when siting terminal in relation to boundary lines.
11. 1,200mm separation measured between a vertical flue and a horizontal flue terminal. Not required if the horizontal flue is 1,500mm above vertical flue terminal.
12. 1,000mm (BS 5410-1) above, below and either side of an opening door, air vent or opening window. These clearances are required by BS 5410 Part 1 to reduce a possible plumbing nuisance. If 1,000mm cannot be achieved then the distance can be reduced to 600mm to comply with Approved Document J of the building regulations if it will not cause a nuisance or dispute.

13. 300mm adjacent to a boundary line unless it will cause a nuisance. BS 5410: Part 1 recommended that care is taken when siting terminal in relation to boundary lines.
14. 1,500mm vertically between terminals and the same wall.
15. 1,000mm (BS 5410-1) below eaves, gutters and sanitary pipe and 300mm from vertical sanitary pipes and drains.  
If 1,000mm cannot be achieved then the distance below eaves, gutters and sanitary pipe can be reduced to comply with Approved Document J of the building regulations if it will not cause a nuisance or dispute. 75mm if combustible material is protected or 600mm without protection to combustible material.<sup>1)</sup>
16. The dimension below eaves, gutters, pipes and drains can be reduced to 75mm, as long as the flue terminal is extended by 100mm past any overhang. The telescopic flue joint must be sealed with suitable silicone sealant if it is external to the building
17. 1,200mm between terminals facing each other.
18. 2,500mm (BS 5410-1) distance to a surface or boundary line. If 2,500mm cannot be achieved then the distance can be reduced to 600mm to comply with Approved Document J of the building regulations if it will not cause a nuisance or dispute.
19. Terminals must be at least 1,800mm from an oil storage tank unless a wall with of at least 30 minutes fire resistance and extending 300mm wider and higher than the tank is between the tank and the terminal. The flue air intake must be at least 900mm away from the oil storage tank vent.
20. 1000mm diagonally to an opening door, air vent or opening window.
21. 300mm to an internal or external corner. 300mm above a surface, such as the ground/ floor level or roof surface.
22. The dimension below eaves, balconies and car ports can be reduced to 75mm, as long as the flue terminal is extended to clear any overhang. The telescopic flue joint of the terminal must be sealed with suitable silicon sealant if it is external to the building.
23. 1,000mm (BS 5410-1) from an opening or vented window, 300mm to a fixed unvented window. If 1,000mm cannot be achieved then the distance from an opening or vented window can be reduced to 600mm to comply with Approved Document J of the building regulations if it will not cause a nuisance or dispute.
24. The flue terminal must be at least 1,500mm from the opening or vented skylight when sited below the opening or vented skylight.
25. Proximity of flue duct outlet to boundaries, 2000mm distance to an opening in adjacent building facing a terminal. BS 5410: Part 1 recommended that care is taken when siting terminal in relation to boundary lines.
26. The distance between a boundary facing a flue terminal can be measured diagonally from the point of discharge with a minimum distance of 600mm which must be maintained. The exclusion zone ensures compliance with Approved Document J of the building regulations.
27. For the purpose of determining suitable flue terminal positions for oil appliances discharging over public boundaries, the boundary can be considered to extend to the centre line of any adjacent routes or waterways e.g. paths, streets, rights of way, canals, rivers or railways.



**NOTICE:**

- ▶ Installations in car ports are not recommended.
- ▶ Dimensions from a flue terminal to a fanned air inlet to be determined by the ventilation equipment manufacturer.

1) A way of providing protection of combustible material would be to fit a heat shield at least 750mm wide.

## 4.9 Flue options

### 4.9.1 Conventional flue (CF)

- Open (conventional) flued appliances must not be installed in a bedroom, bathroom, bed-sitting room, or garage.
- The flue system must be in accordance with BS 5410 : Part 1 and the current Building Regulations.
- The flue must be constructed of materials suitable for use with condensing combustion products.
- External flue systems must be of the insulated type.
- Brick and masonry chimneys must be lined with a suitable non-combustible material and properly jointed to withstand the effects of the working temperature (minimum rating of material 120°C) of the appliance and any condensate which may form.
- All flue joints must be sealed to prevent the leakage of condensate and combustion products.
- Ensure that joints are made so that the condensate runs away and is not collected within the joint.



The flue can be increased in size from the boiler take off point providing the joint is correctly sealed. Never reduce the flue diameter from the boiler take off point.

#### CF Sizing:

- ▶ 12/18 and 18/25 = 100/103mmØ
- ▶ 25/32 = 130mmØ\*

#### \* Unless installing a Worcester Greenstar Oilfit Conventional Flexible flue.

- Because the flue operates at a lower temperature on a condensing boiler compared to that of a conventional appliance, the flue draught will be lower. Typically the draught will be between 0.5mmwg and 4.4mmwg, measured with the flue warm but the burner not firing. The actual figure will vary depending on weather conditions, flue height and position.
- The flue should be vertical and contain as few bends as possible, a maximum of two 135° bends should be used.
- The flue outlet must be extended beyond the eaves of the building and where possible, above the apex.
- Fit a suitable anti down-draught terminal where down draughts are experienced.

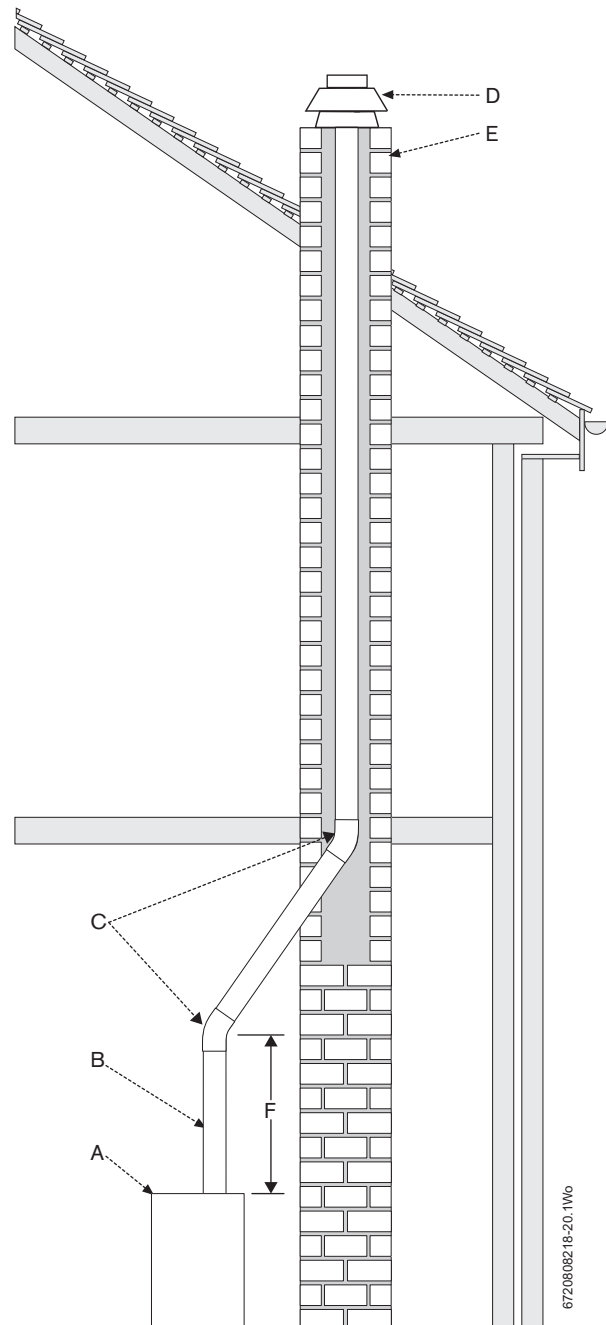

Fig. 26 Conventional flue

- [A] Boiler
- [B] Stainless steel flue
- [C] Max. two bends at 135°
- [D] Anti down-draught terminal
- [E] Chimney
- [F] Height to first bend from top of boiler (min. 600mm)

**4.9.2 Room sealed flue options**

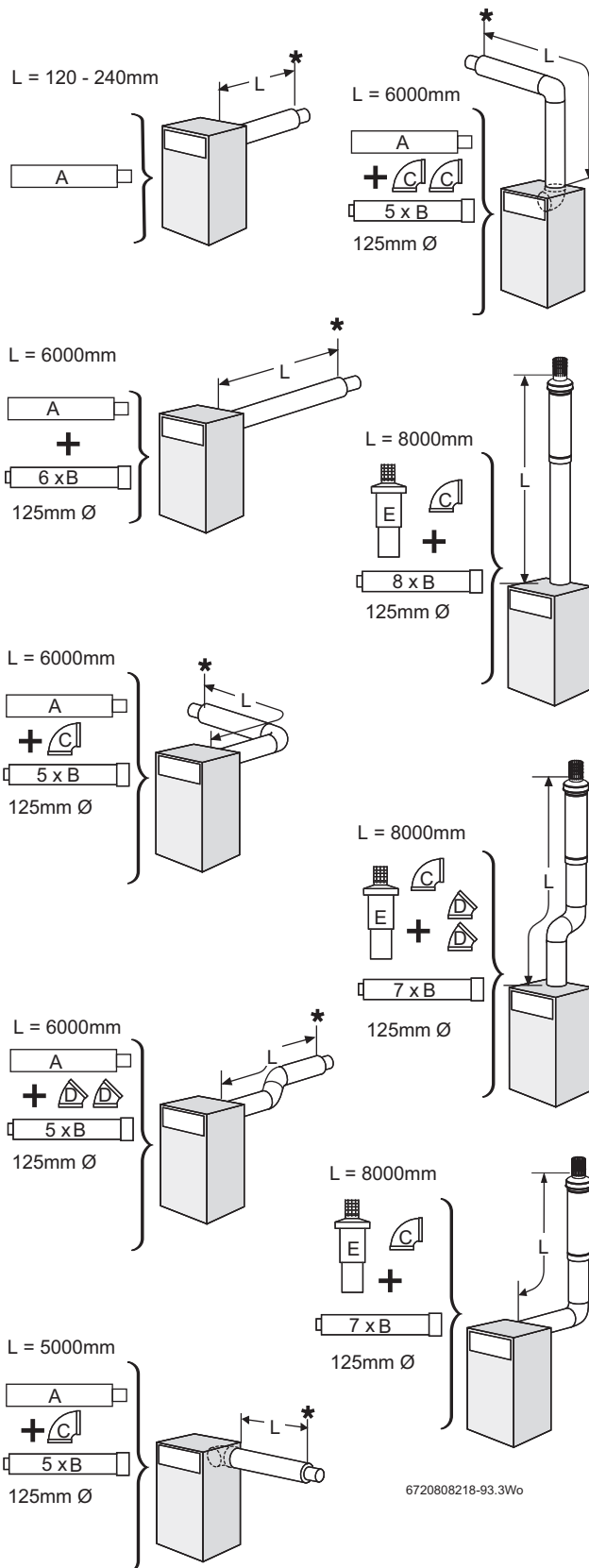

Fig. 27 Room sealed flue options

- [A] Flue terminal
- [B] Flue extension
- [C] 90° bend
- [D] 45° bend
- [E] Vertical flue terminal

Figure 27 shows the components used and the maximum flue length (L) for each flue configuration.

In all cases L is measured from the outside of the boiler casing.

- To achieve the maximum flue length (L), a flue section will have to be reduced in length.
- Only the flue terminal or straight flue extensions can be reduced in length by cutting.
- The flue terminal end can be fitted from the inside or outside of the building.



All horizontal sections must rise away from the boiler by 52mm per metre (3°) to allow the condensate to drain back to the boiler.

**Calculating the flue length**

Measure the total flue length required, noting that the maximum straight flue length including the terminal is:

Horizontal 80/125mm Ø: 6000mm (excluding 120mm of terminal extending outside the building)

Vertical 80/125mm Ø: 8000mm (measured from the boiler top panel).

Then reduce the total straight flue length for each extra flue bend (excluding the vertical flue kit 90° elbow) by:

- 1000mm for 90°
- 500mm for 45°

**Flue extension lengths**

Horizontal & Vertical 80/125mm Ø: 1000mm overall length.

Effective length when engaged into sockets within the flue run is 950mm.

**Flue terminal lengths**

Horizontal 80/125mm Ø: 720mm

Vertical 80/125mm Ø: 1080mm + cage

\* to outside wall.

## 4.10 PLUME MANAGEMENT

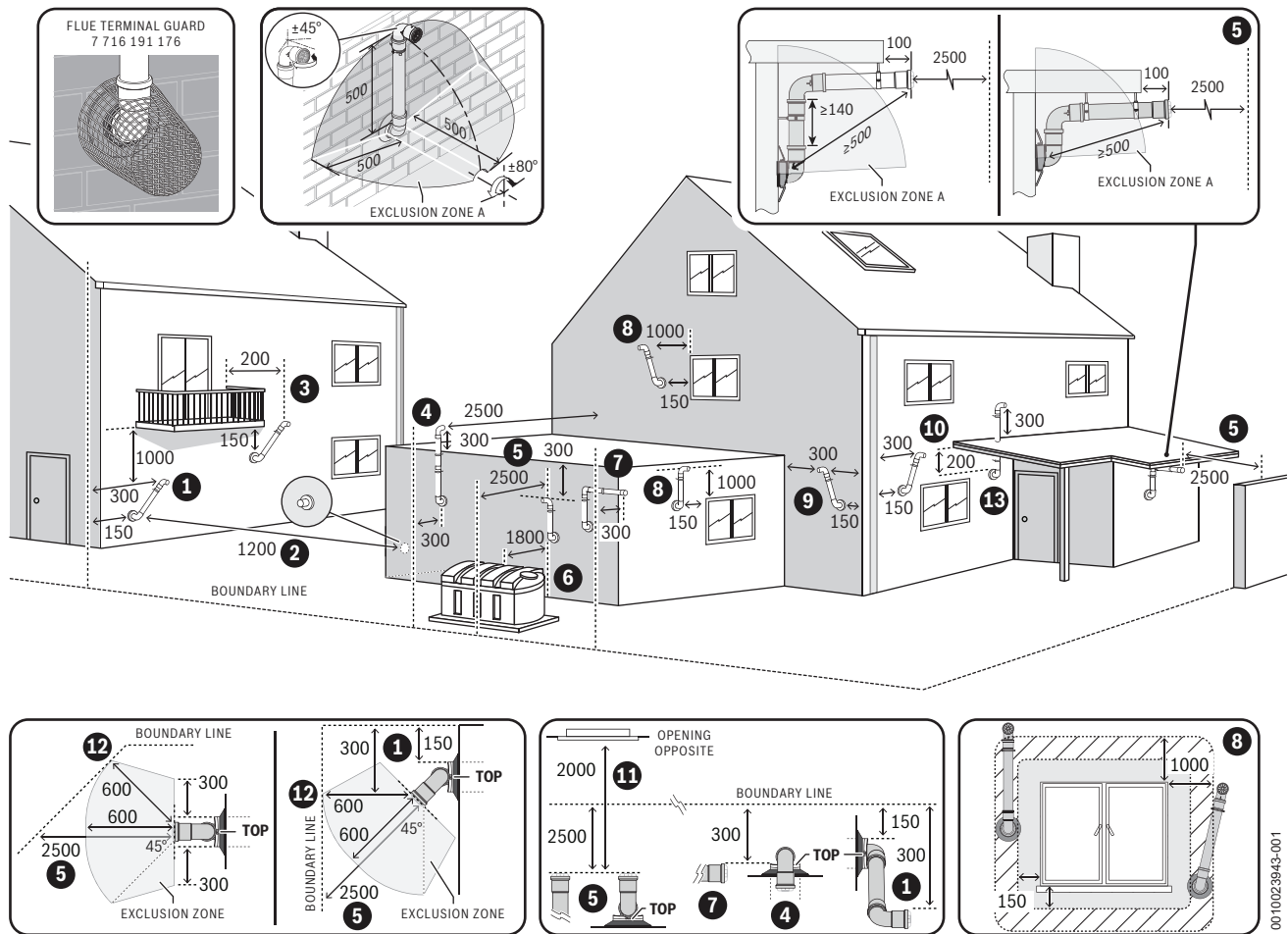

Fig. 28 Plume terminal positions



### NOTICE:

- ▶ All measurements are the minimum clearances required.
- ▶ Terminals must be positioned so to avoid combustion products entering the building.
- ▶ Support the flue at approximately one metre intervals and at a change of direction, use suitable brackets and fittings.

### KEY TO ILLUSTRATION

1. Plume Management kit air intake can be reduced to 150mm providing the flue exhaust outlet is no less than 300mm adjacent to a boundary line.
2. 1,200mm between the terminals on opposing walls. Where two plume management kits are used 1200mm must be maintained between both opposing terminals and air inlets. Each terminal should use a minimum length of 500mm plume management
3. Below balcony or overhang. The air intake clearance can be reduced to 150mm providing the flue exhaust outlet has a 1000mm clearance in BS 5410-1.
4. 300mm distance from a boundary line to the air intake as long as the exhaust terminal faces away from the boundary line. The exhaust terminal must have a minimum 300mm clearance to a surface below and there must be at least 2,500mm (BS 5410-1) clearance when measured horizontally in a straight line from the exhaust outlet to any other surface. If 2,500mm cannot be achieved then the flue exhaust outlet distance can be reduced to 600mm to comply with Approved Document J of the building regulations if it will not cause a nuisance or dispute.
5. 2,500mm (BS 5410-1) distance to a surface or boundary line. If 2,500mm cannot be achieved then the distance can be reduced to 600mm to comply with Approved Document J of the building regulations if it will not cause a nuisance or dispute.
6. Terminals must be at least 1,800mm from an oil storage tank unless a wall with of at least 30 minutes fire resistance and extending 300mm wider and higher than the tank is between the tank and the terminal. The flue air intake must be at least 900mm away from the oil storage tank vent.
7. 300mm adjacent to a boundary line unless it will cause a nuisance. BS 5410: Part 1 recommended that care is taken when siting terminal in relation to boundary lines.
8. Above, below and either side of an opening door, air vent or opening window. Using a Plume Management kit the air intake measurement can be reduced to 150mm providing the flue exhaust outlet has a 1,000mm (BS 5410-1) clearance. If 1,000mm cannot be achieved then the flue exhaust outlet distance can be reduced to 600mm to comply with Approved Document J of the building regulations if it will not cause a nuisance or dispute.
9. Internal/external corners. The air intake clearance can be reduced to 150mm providing the flue exhaust outlet has a 300mm clearance.
10. Vertical sanitary pipe: 150mm to the flue air intake and 300mm to the flue exhaust outlet.
11. Proximity of flue duct outlet to boundaries, minimum 2,000mm distance to an opening in adjacent building facing a terminal. BS 5410: Part 1 recommended that care is taken when siting terminal in relation to boundary lines.

12. The distance between a boundary facing a terminal can be measured diagonally from the point of discharge with a minimum distance of 600mm which must be maintained. The exclusion zone ensures compliance with Approved Document J of the building regulations,
13. A plume management kit must not be terminated within the confines of a carport or other covered, partially enclosed extension. The exhaust terminal must be sited at least 300 mm beyond the footprint of the structure, and maintain a distance of at least 600mm to any opening sited within the confines of the structure.

The exhaust terminal can also be routed through the roof of the carport providing 25mm clearance is provided around the flue pipe to any flammable material and that it extends at least 300mm above the roof. The air intake must have a minimum 150mm clearance to any opening in the building in order to ensure the integrity of the structure is maintained. If the air intake is sited within the footprint of the carport then the carport must have at least one completely open side.



- ▶ The flue cannot be lower than 1,000mm from the top of a light well due to the build up of combustion products.
  - ▶ Plume kits running horizontally must have at least a 3° fall back to the appliance for proper disposal of condensate. The initial plume kit horizontal run will have at least a 10° fall back to the appliance, due to the terminal elbow design, for proper disposal of the condensate.
-

## 5 Installation

### 5.1 Unpacking the boiler



**CAUTION:** Lifting and carrying

- ▶ Lift only a manageable weight, or ask for help.
- ▶ When lifting or putting things down, bend your knees, keep your back straight, and feet apart.
- ▶ Do not lift and twist at the same time.
- ▶ Lift and carry object close to your body.
- ▶ Wear protective clothing and gloves to protect against sharp edges.



**NOTICE:** Before installation

- ▶ All the previous Pre-Installation sections must be read and requirements met before starting boiler or flue installation.

#### Unpacking

It is advised that at least two or more people are involved in the transfer of the packaged boiler from the van to the point of delivery.

1. Once the packaged boiler has been delivered, the outer carton is removed first.  
Care should be taken when releasing the straps. If a sharp implement is used make sure the outer carton is not pierced and that the implement is used in such a way so that it may not cause personal injury. All sharp objects must be covered or the blade retracted after use and put away in a safe place.
2. Lift carton up and away from the boiler.
  - ▶ Remove the plastic bag and upper front protection cover from the boiler and place safely aside.
  - ▶ Two or more people are required to move the boiler. taking care not to damage the boiler, panels or the floor.



**NOTICE: Heavy objects**

- ▶ At all times the correct method for handling heavy objects should be strictly observed.

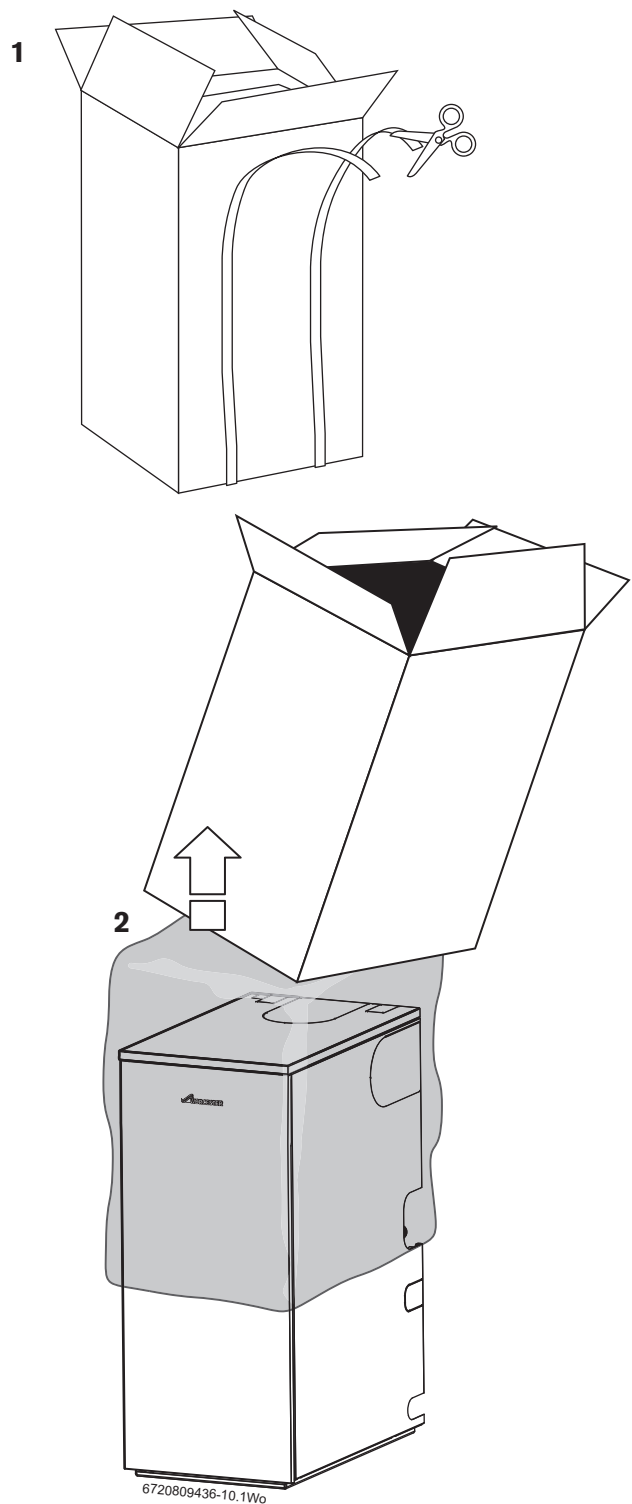

Fig. 29 Unpacking

## 5.2 Pipework positions and flue opening

**CAUTION: Drilling**  
 ▶ Ensure there are no pipes, electrical cables, damp proof courses or other hazards before drilling.

### Safety

All relevant safety precautions must be undertaken. Protective clothing, footwear, gloves and safety goggles must be worn as appropriate.

### Pipework connections - Regular

- A - Flow connections (optional combined feed and vent) 1" BSP
- B - Return connections 22mmØ copper on 12/18, 18/25 models and 28mmØ copper on 25/32 models
- C - Condensate outlet 21.5mm Ø
- D - Flue outlet
- E - Oil pipe optional centres
- F - Optional oil line return line connection

**i** For servicing purposes, keep condensate discharge pipe away from components and pipework connections.

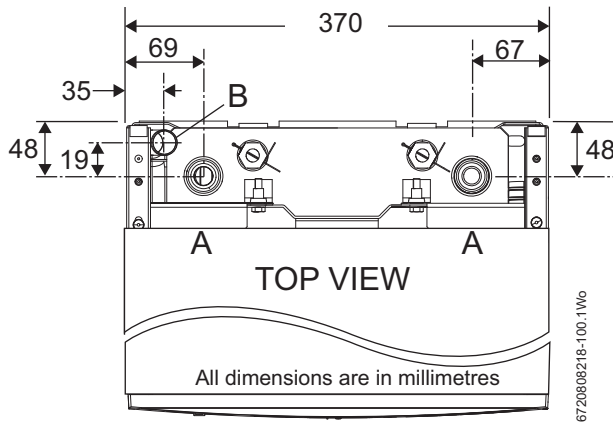

Fig. 30 Top view of Regular boiler pipe connections

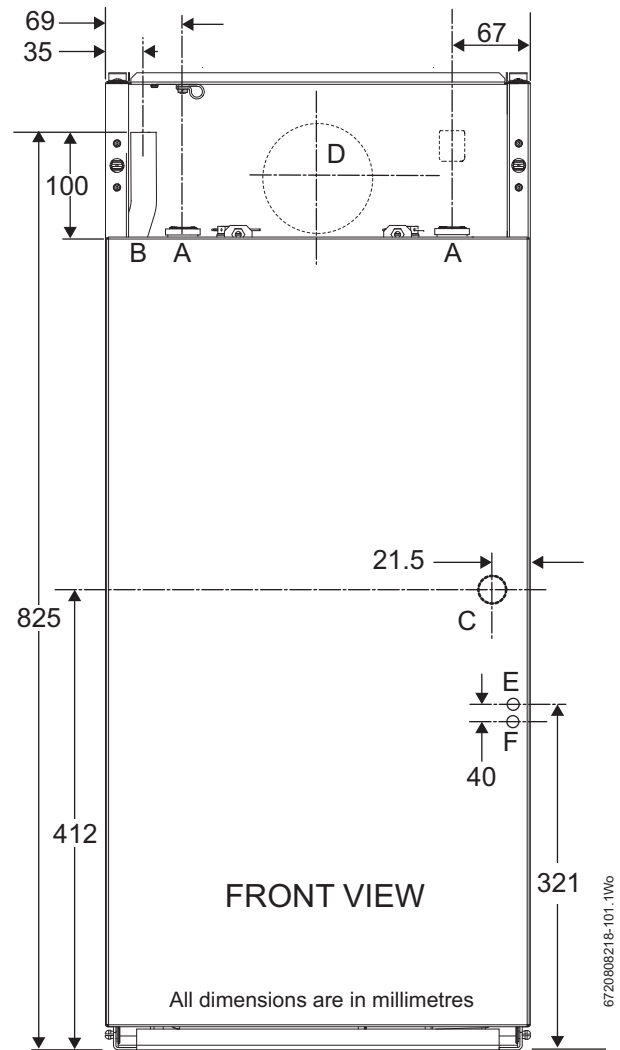

Fig. 31 Front view of Regular boiler pipe connections

**Pipework connections - System**

- A - Flow connections 12/18 & 18/25 - 22mm Ø, 25/32 - 28mm Ø
- B - Return connections 22mmØ copper on 12/18, 18/25 models and 28mmØ copper on 25/32 models
- C - Condensate outlet 21.5mm Ø
- D - Flue outlet
- E - Oil pipe optional centres
- F - Optional oil line return line connection
- PRV - 15mm Ø

**i** For servicing purposes, keep condensate and pressure relief discharge pipes away from components and pipework connections.

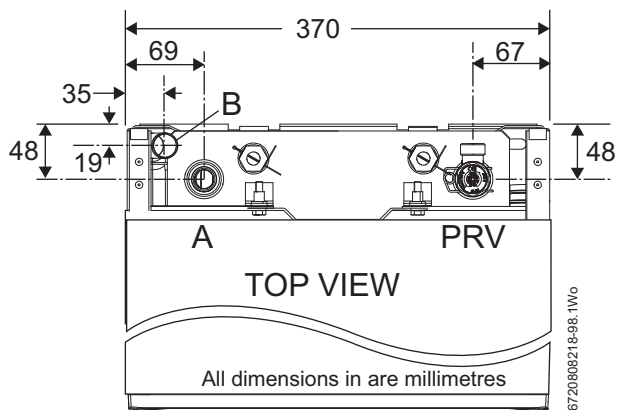

Fig. 32 Top view of System boiler pipe connections

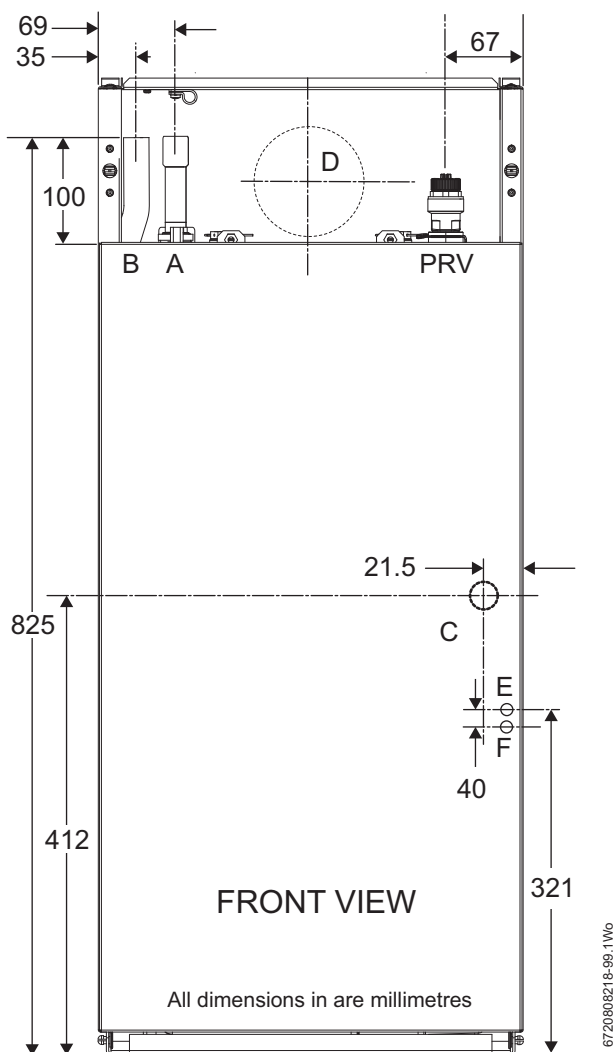

Fig. 33 Front view of System boiler pipe connections

**Flue centres**

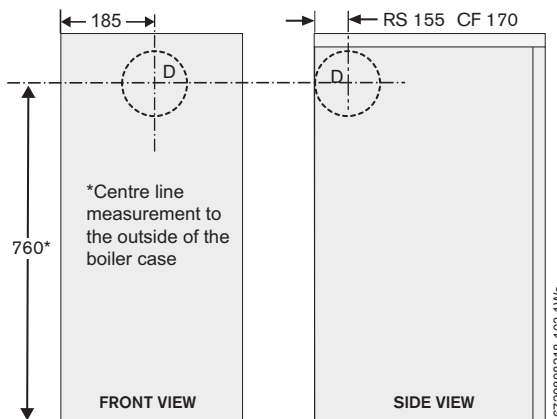

Fig. 34 Flue centres

**Flue opening**

- ▶ Follow figure 35 to mark the centre of the flue (1, & 2) for rear opening, (2 & 3) for side opening or (1 & 4) for top opening.

**i** All horizontal flue sections must rise away from the boiler by 52mm per metre to ensure that condensate flows back into the boiler for safe discharge via the condensate waste pipe.

- ▶ Make an opening (F, G or H) using a core drill or similar at a size relative to the wall thickness as shown below:

125mm Ø flue:	
Wall thickness mm	Flue hole size Ø mm
150 - 240	155
240 - 330	160
330 - 420	165
420 - 500	170

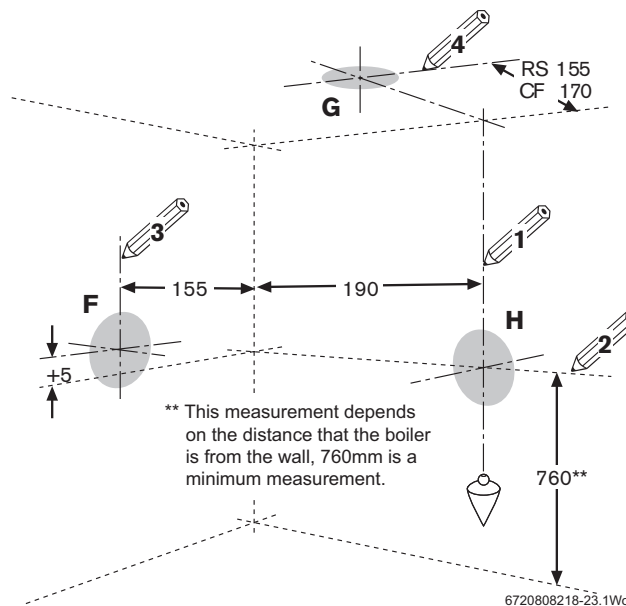
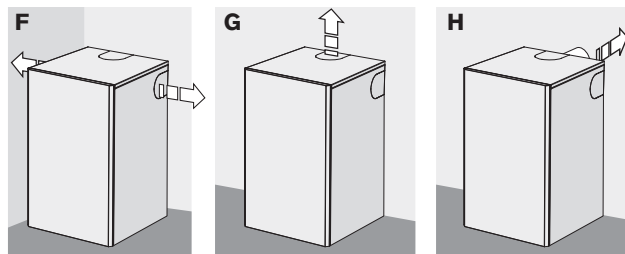

Fig. 35 Flue opening

### 5.3 Boiler installation

1. Lift the front of the top panel (A) upwards to disengage the ball stud connections (B) and pull forwards to release from the brackets (C) at the back to remove. Pull front panel (D) forward from the bottom and near the top disengaging the ball studs from their connections (E) and lift off the ledge (F) that runs along the bottom of the fascia to remove.
2. Unplug burner lead (G) from control box.

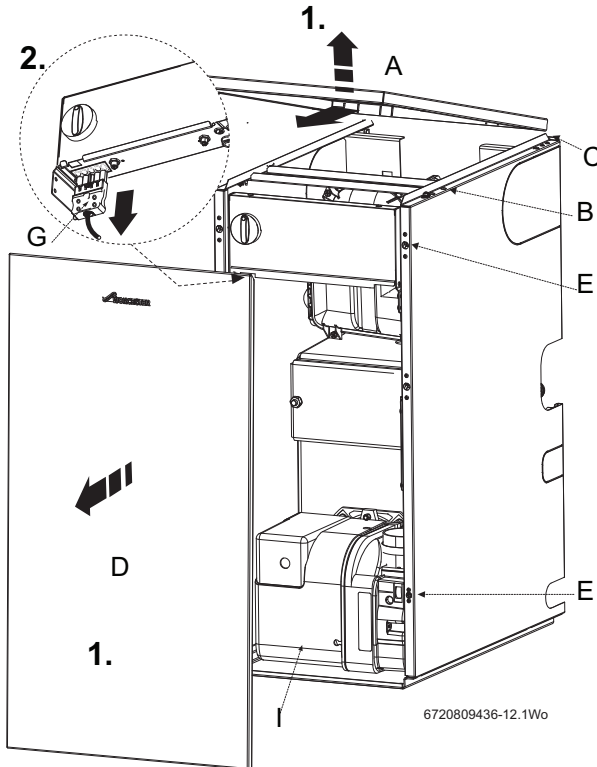

Fig. 36 Boiler installation

#### Utility system only:

- In the case of the Utility system boiler, remove the retaining screw [1] at the base of the expansion vessel.
- Pull the expansion vessel forward slightly and down to remove. Place the expansion vessel outside of the boiler, taking care not to kink or stretch the flexible hose.

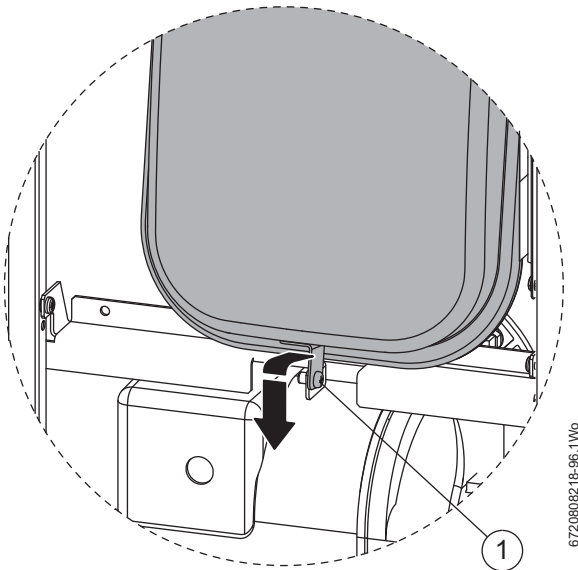

Fig. 37

3. Unscrew to loosen the retaining ring (H) that secures the flexible air supply tube to the burner and pull the flexible air supply tube free from the burner (see figure 38).

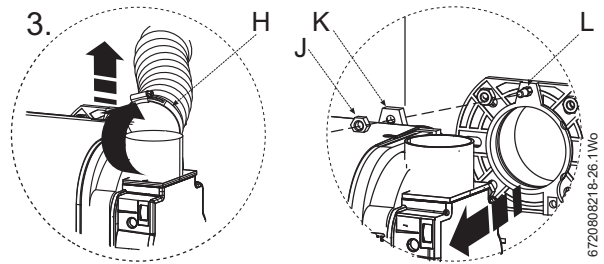

Fig. 38

- Undo and remove the retaining nut (J) on top of the burner. The burner mounting (K) can now be eased off the lug (L) on the burner collar to remove the burner from the heat exchanger. Store the burner and retaining nut safely away from the boiler.
- Carefully move the boiler into position observing at all times the correct method for handling heavy objects.

### 5.4 Flue installation

The flue can exit the boiler from outlets A, B, C or D allowing vertical (RS) and horizontal (RS low or high level) flues to be fitted. (CF position 'A' only).

Refer to the separate flue installation instructions supplied with the flue kits available for this boiler:

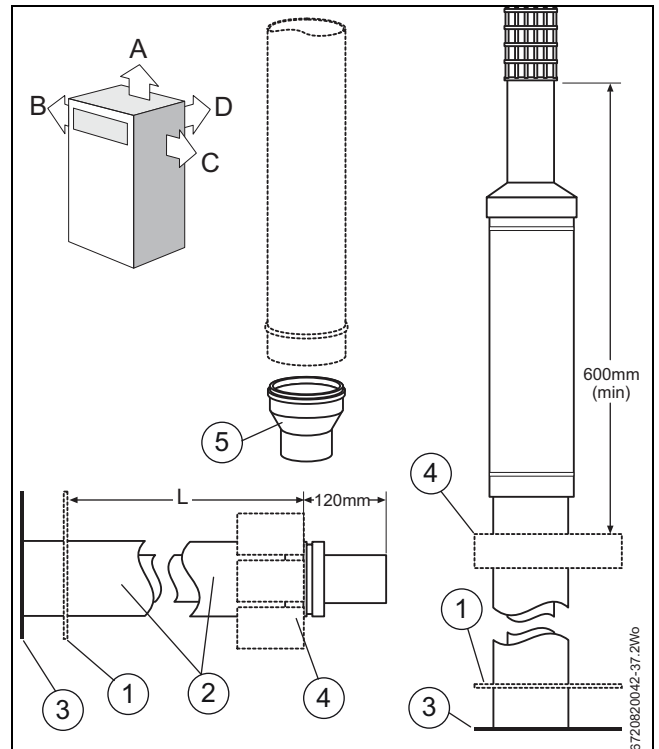

Fig. 39

- [1] Boiler outer casing
- [2] Outer flue tube
- [3] Outlet/elbow connection
- [4] Outside wall/roof
- [5] CF adaptor
- [L] Effective length of the flue

### 5.4.1 Flue damper installation



**NOTICE:** Fitting the flue damper  
Failure to fit the flue damper, when required will effect the performance of the boiler and may cause "Lockouts"



The flue damper is only fitted to models stated in the table below

Model range	Output (kW)	Flue damper fitted
<b>12/18</b>	13	Yes
	15	Yes
	18	Yes
<b>18/25</b>	18	Yes
	21,5	Yes
	25	Yes
<b>25/32</b>	25	No
	28	No
	32	Yes ≤ 4m flue length
	32	No > 4m flue length

Table 9

Insert the flue damper into the inner tube of the straight extension or 90° elbow and fit the flue as shown in figure 40. Ensure that the rubber seal is fitted into the inner tube.

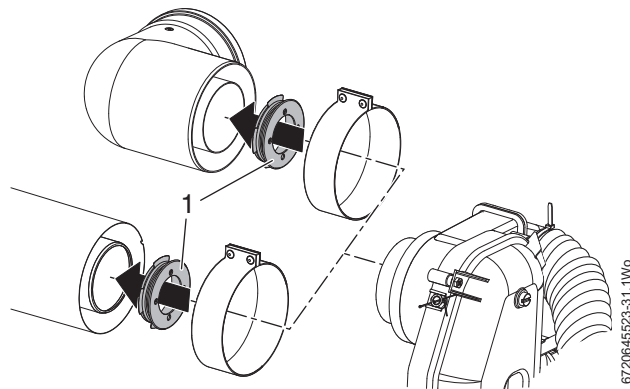

Fig. 40 Flue damper fitting

### 5.4.2 Installation notes

- ▶ If using an extension or horizontal terminal onto the boiler outlet, remove the flue elbow retaining bracket [6].



**WARNING:** Escaping flue gases  
The flue elbow and clamp may become loose.  
▶ The flue elbow retaining bracket [6] must be fitted if a flue elbow is used on the boiler outlet.

- ▶ When connecting a flue elbow [8] directly to the boiler flue outlet, loosen the flue elbow retaining bracket screws [7] before fitting the flue elbow. Insert the flue elbow with the flue retaining clamp [9] loosely fitted, then tighten the bracket screws [7].
- ▶ Orient the flue elbow into the required position and secure with the clamp.
- ▶ Ensure all flue seals are in good condition and seated properly.
- ▶ To ease assembly of flue components, grease seals lightly with the solvent-free grease supplied.
- ▶ A clamp should be installed for every 1m and at every change of direction.



The boiler is not designed to take the weight of the flue system, this must be supported externally to the boiler.

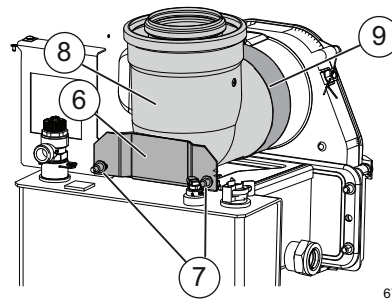

6720813284-25.1W0

Fig. 41

- ▶ All horizontal flue sections must rise by at least 52mm for each metre (3°) away from the boiler to ensure that condensate flows back into the boiler for safe discharge via the condensate waste pipe.
- ▶ The horizontal terminal must be installed at 3° to ensure that the condensate drains back to the boiler whilst also preventing rain ingress down the air duct.

**5.5 Combustion chamber (18/25 Regular shown)**

1. Remove the control box securing screws (A, bottom screw both sides) and loosen the pivot screws (B, top screw both sides).
2. Lower the control box into the service position.

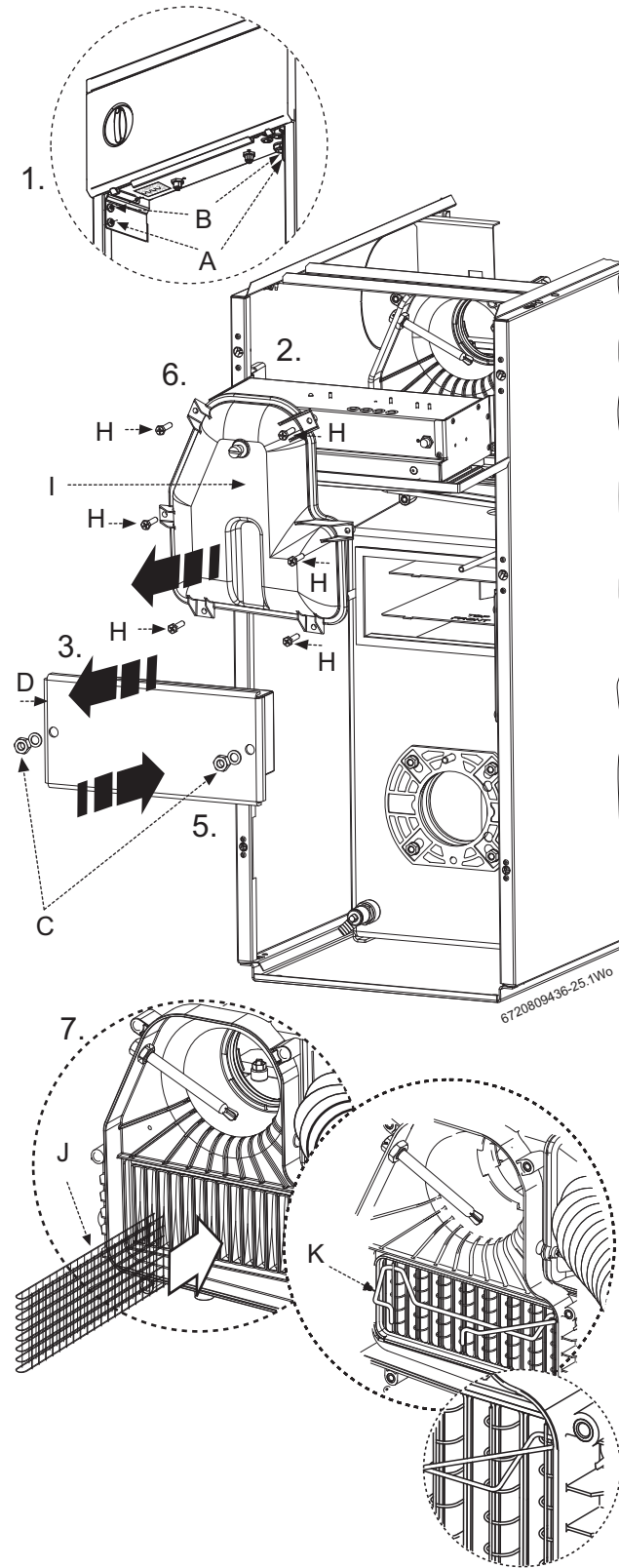

Fig. 42 Combustion chamber

3. Release retaining nuts and washers (C).  
Remove baffle/combustion chamber access door (D).
4. Ensure one piece baffle set (E) is in the right location (F), correctly resting on the baffle rests (G) on either side of the combustion chamber and pushed securely into place.  
Baffle sets for the 18/25 and 25/32 boilers are identified with tabs on the front and rear edge

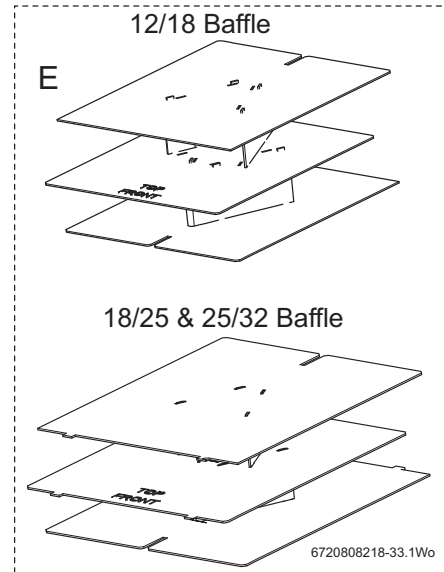

Fig. 43 Baffle arrangement

5. Secure baffle/combustion chamber access door (D) with nuts and washers (C). Tighten until door is firmly secured. Do not overtighten the nuts.
6. Release the screws (H) and remove flue manifold access cover (I).
7. Check that all the baffles (J) and baffle retainer (K) are correctly fitted to the secondary heat exchanger.  
Hook the retainer (K) over the end two baffles.
8. Check that the flue damper is correctly fitted, if required, refer to section 5.4.1

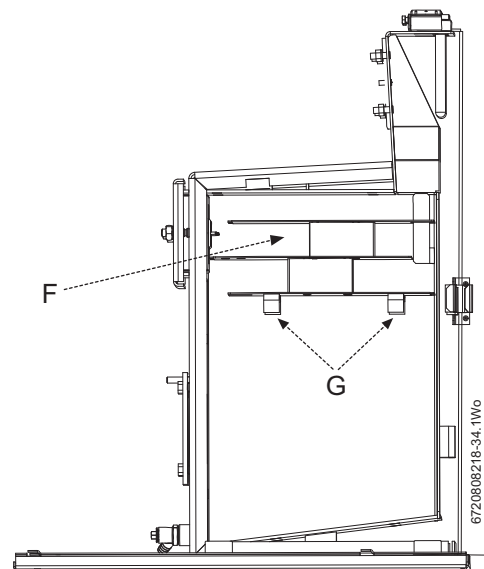

Fig. 44

**5.6 Pipework connections**

**CAUTION: MAINS SUPPLIES**

▶ Isolate the oil & water mains supply before starting any work and follow all relevant safety precautions.

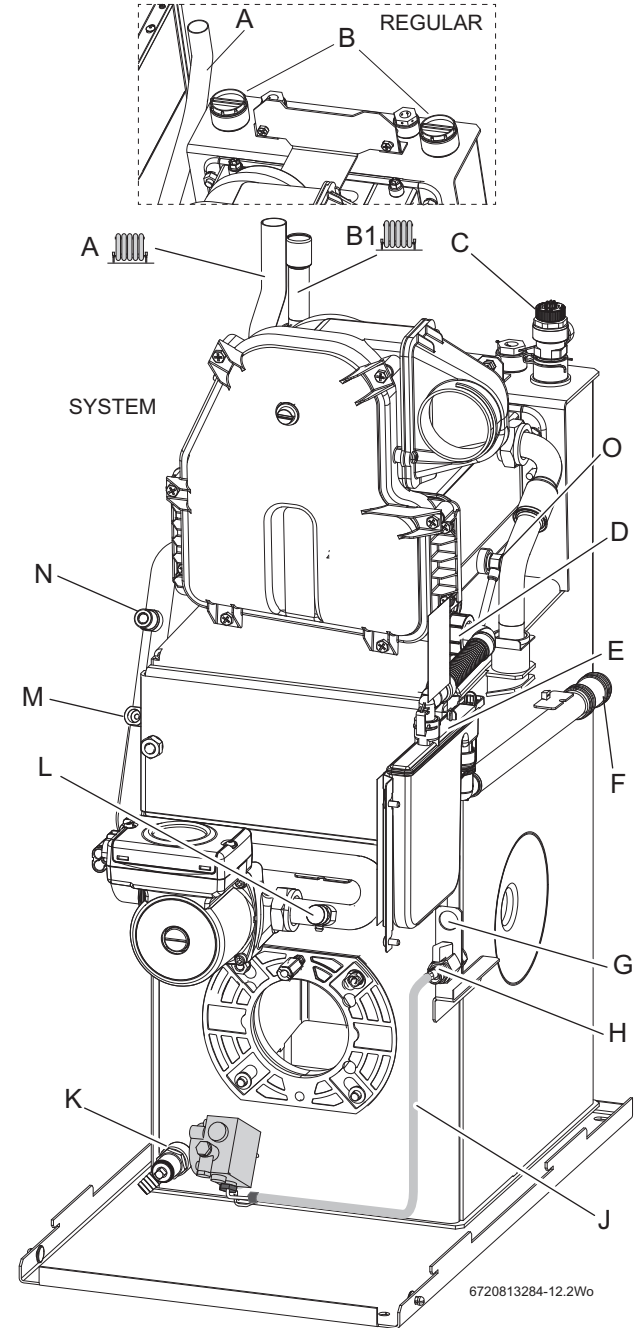

Fig. 45 Pipework connections

- [A] Return connection 22mm Ø copper (28mm Ø on 25/32 models)
- [B] Flow & optional combined feed and vent 1" BSP
- [B1] Flow connection 22mm copper (28mm on 25/32 models)
- [C] Pressure relief valve
- [D] Flue manifold condensate outlet
- [E] Condensate trap - supplied
- [F] Condensate outlet & flexible push fit connection (21.5mmØ)
- [G] Fixing point for optional oil return pipe
- [H] Oil isolating valve (10mmØ)
- [J] Flexible oil hose and routing
- [K] Primary Drain (hose connection)
- [L] Pump circuit drain point
- [M] Pressure gauge connection
- [N] Expansion vessel connection
- [O] Secondary heat exchanger drain point

**Water connections**

- i** Surplus water may be present due to factory testing.
- ▶ Remove the transit bungs from the boiler pipework connections.
  - ▶ Ensure all of the pipework is clean.
  - ▶ Align the water pipework and connect. The 12/18 and 18/25 return pipe only, may be cut to simplify pipe routing externally to the boiler.
  - ▶ Check that all the unused sockets have been capped.

**Return pipe connection**

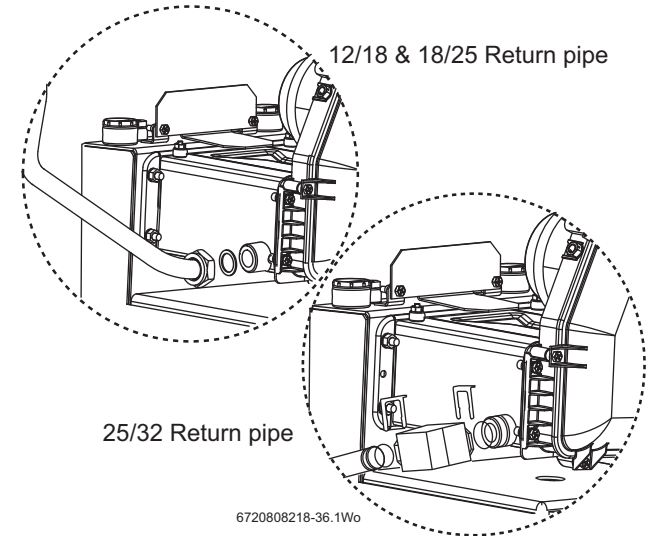

Fig. 46 Return pipes

**Oil supply connections**

- ▶ Refer to figure 45 and ensure that the isolating valve (H) is fully closed and route the oil supply pipe along the right side of the boiler and connect to the isolating valve (H).

**Condensate connection**

- ▶ Connect the 21.5mm polypropylene pipe (not supplied) to the condensate waste pipe flexible push fit connector (F) and terminate to waste. Do not use any solvents, adhesives or lubricants when pushing the pipe into the flexible push fit connector (F).
- ▶ Ensure that the condensate pipe runs away from the boiler at a constant fall of 52mm (minimum) for every metre.
- ▶ Carefully pour 500ml of water into the condensate collection (P) to fill condensate trap.
- ▶ Check the water is running away and the condensate pipework joints are water tight.
- ▶ Check the flue manifold seal (within the rim recess of the flue manifold access cover) is undamaged and seated correctly.
- ▶ Refit flue manifold access cover (R) and secure with screws (S).

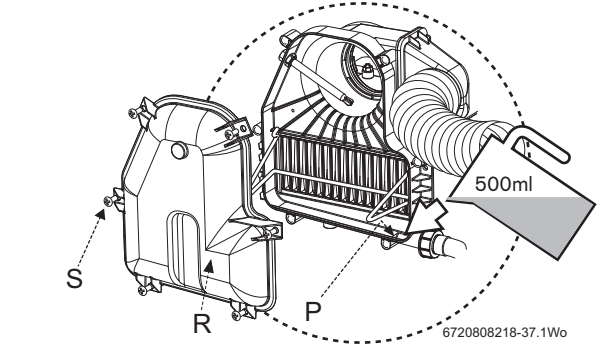

Fig. 47 Condensate

- [P] Condensate collection sump
- [R] Manifold access cover
- [S] Screws

**Fire valve**

Where required, check that the oil supply pipe has a fire valve fitted externally to the building with the fire valve sensor located within the appliance case.

A fire valve sensor clip [1] is provided for this purpose on the support bar between the side panels.

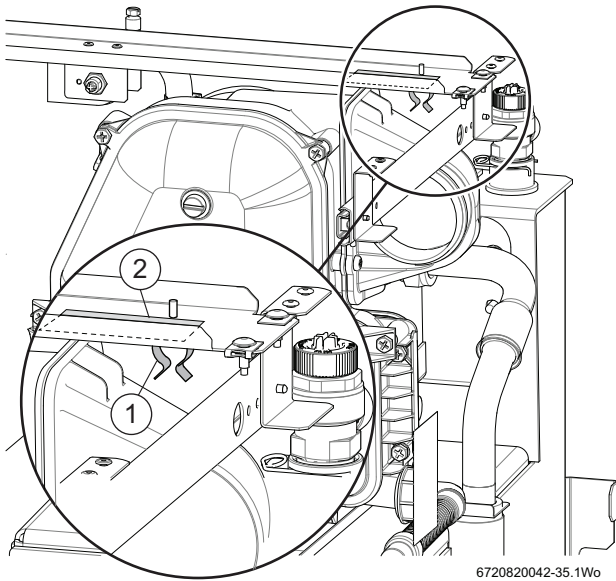

Fig. 48 Fire valve clip

- [1] Fire valve clip
- [2] Fire valve label

The fire valve label [2] states that the fire valve should be rated at 85°C or above to avoid nuisance cut outs.

**5.7 Oil burner and pump**

**CAUTION: MAINS SUPPLIES**

- ▶ Isolate the oil & water mains supply before starting any work and observe all relevant safety precautions.

**NOTICE: Nozzle orifice contamination**

- ▶ to avoid contamination do not dismantle, clean or touch the nozzle tip

**Oil burner nozzle**

Before removing or fitting a new nozzle refer to figure 49:

- ▶ Remove the screws [1] from the blast tube [2] and remove the blast tube

**i** There is a recirculation tube fitted to the 12/18 models, this does not need to be removed from the blast tube

- ▶ Unplug the HT leads [4]
- ▶ Loosen the screw [3] securing the break plate [5] and slide the unit off
- ▶ Use a suitable spanner to stop the nozzle body turning
- ▶ Remove the nozzle [8] and secure the new nozzle, hand tight
- ▶ Tighten the nozzle utilising the two spanners used during removal, do not overtighten
- ▶ Refit the break plate ensuring that the photocell and the break plate hole [5] are aligned and secure with the screw [3] into the seating provided [7]
- ▶ Reconnect the HT leads [4]
- ▶ Refit the blast tube [2] and secure with the screws [1]

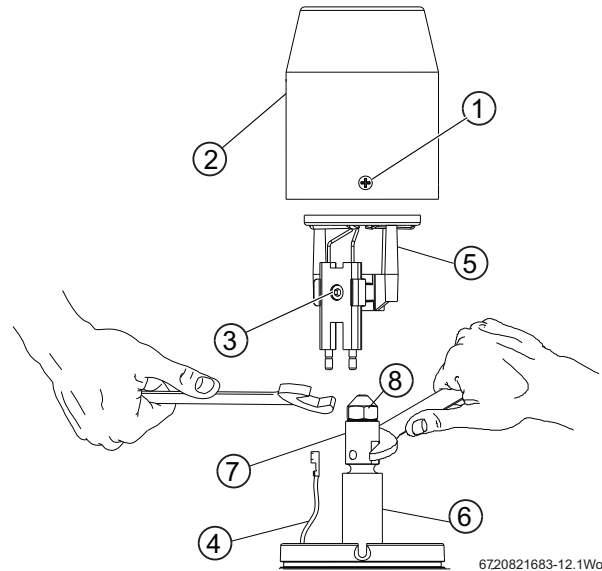

Fig. 49 Nozzle access

Refer to figure 50:

- ▶ Check that the nozzle [1] and the electrode [2] alignment settings are correct.
- ▶ Ensure that the nozzle [1] is aligned centrally within the combustion head [3].
- ▶ Inspect for any visible defects.

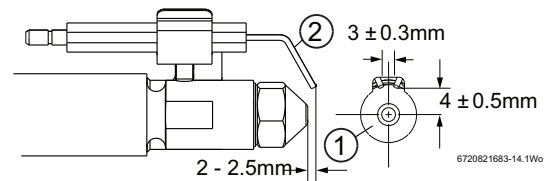

Fig. 50 Nozzle and electrode alignment

**Burner head adjustment**

The burner head adjustments are made to achieve the required output from the burner. The adjustments are made via a thumb-wheel on the burner. Refer to section 6.4.4 for setting information.

**Oil pump - Single pipe connection**

Connecting the oil pump for a single pipe system:

- ▶ The pump is factory set for single pipe operation with the flexible oil pipe fitted.
- ▶ Check connections before use.

**Oil pump - two pipe connection**

Converting the oil pump for a double pipe system:

1. Check the inlet pipe connection.
  - ▶ Unscrew the return plug [1].
  - ▶ Screw in by-pass screw [2] that is supplied in a plastic bag attached to the oil pump.
2. Connect the flexible oil pipe return hose [3] (not supplied) to the oil pump and return pipe fixing and tighten to secure (for routing see figure 45).

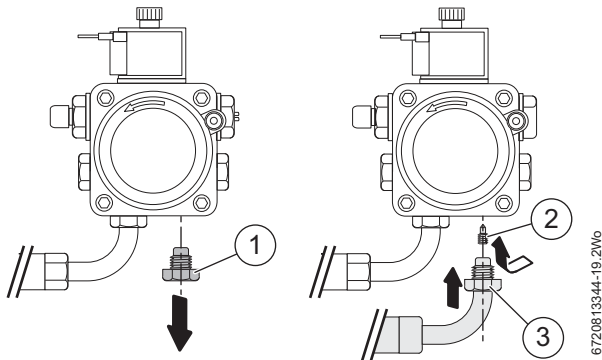

Fig. 51 Converting to double pipe system

- [1] Return plug
- [2] By-pass screw
- [3] Return pipe connection

**5.8 Refitting components**

**WARNING:** Flue gas leakage

The seal between the burner and the mounting flange must form a gas tight seal to prevent leakage of potentially dangerous gas from the combustion chamber.

- ▶ Unless the burner is level when pushing the burner into the flange the O-ring may not seat properly allowing flue gas to escape!
- ▶ Always check that the O-ring seal (Fig 52 item A) is in good condition before fitting the burner. Replace the O-ring seal if defective.

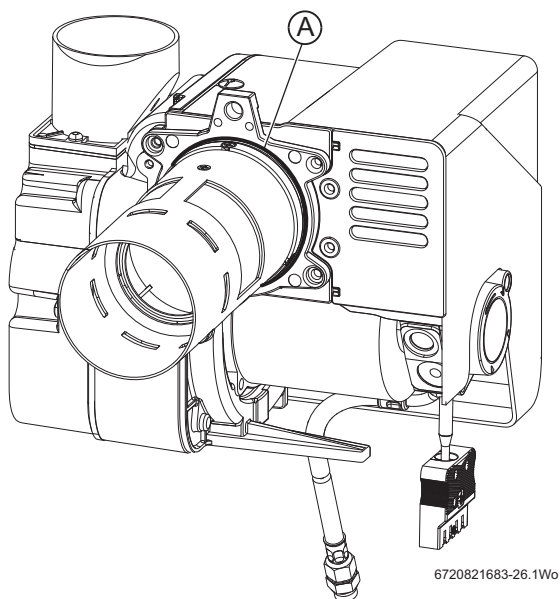

Fig. 52 12/18 Burner O-ring seal shown

Refer to figure 53

1. Align burner combustion head into the boiler collar.
  - ▶ Locate the burner retainer [A] over the threaded lug on the collar [B], ensure that the burner is level and push the burner firmly onto the flange ensuring the O-ring seal is fully engaged. Support the burner in position and secure with the retaining nut [C]. Tighten sufficiently to hold the burner but do not over tighten.
  - ▶ Check that the burner is seated correctly on its mounting flange and that the oil hose/s are routed correctly as shown in Fig. 37 and not trapped in front of or underneath the burner.
2. Attach air duct and tighten clip (D) to secure to the burner air intake.

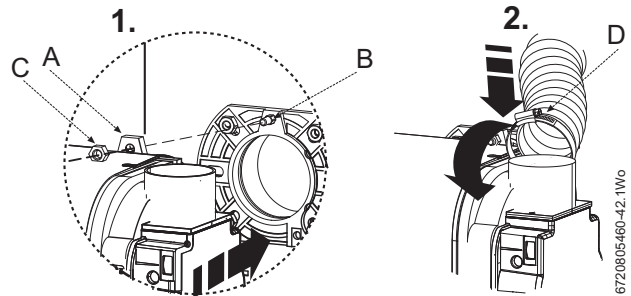

Fig. 53 Refitting the burner

3. Swing control box back up into operating position and retain in place by replacing the two securing screws (E) in the bottom locations.
  - ▶ Plug burner lead (F) into control box.

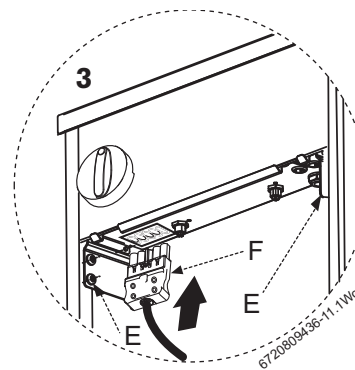

Fig. 54 Refitting the control panel

## 5.9 Electrical

**CAUTION: ISOLATE THE 230V ELECTRICITY SUPPLY**

- ▶ Ensure that the electricity supply is safely isolated and secured to prevent inadvertent re-connection. Information on safe isolation can be found in the Health and Safety Executive guidance HSG85. Using test equipment approved to GS38 confirm that the electricity supply is disconnected.

**i**

- ▶ The mains electrical supply to the boiler and system wiring centre must be common and through a common fused double pole isolator.
- ▶ The isolator shall be sited next to the boiler for new systems and where practicable, replacement boilers.
- ▶ The isolator must have a contact separation of 3mm minimum between all poles.
- ▶ Any additional components that are connected to the boiler with mains electrical supply must not have a separate supply.
- ▶ External 5 Amps.
- ▶ When stripping wires ensure copper strands do not fall into the control box.

### Access to 230V connections

1. Remove the four fascia retaining screws (A) and position the fascia assembly (B) on the two fascia location lugs (C) as shown.
2. Release screws (D) from cable clamp (E).
  - ▶ Feed sufficient power cable (F) through the cable clamp (E) and secure grip with screws (D).
  - ▶ Separate wires from cable end and strip to 6mm.

### 230V connections

3. Connect LIVE wire (Brown) to terminal L.
- ▶ Connect NEUTRAL wire (Blue) to terminal N.
- ▶ Connect EARTH wire (Green/Yellow) to the earth terminal

**i**

Route the power cable down the side panel using the clip on the support panel to the external connection point avoiding any potentially hot surfaces allowing sufficient cable to pivot the control box into the service position.

**NOTICE: External devices**

- ▶ The boiler and any external devices connected to the boiler must have a single point of isolation. See the following pages of electrical diagrams for details of different systems.

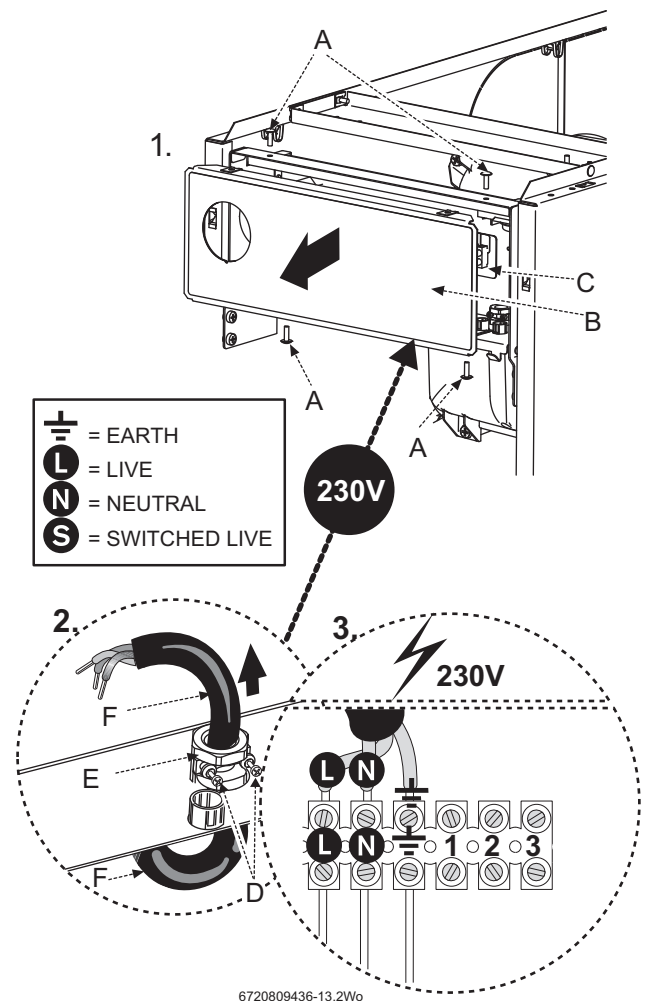
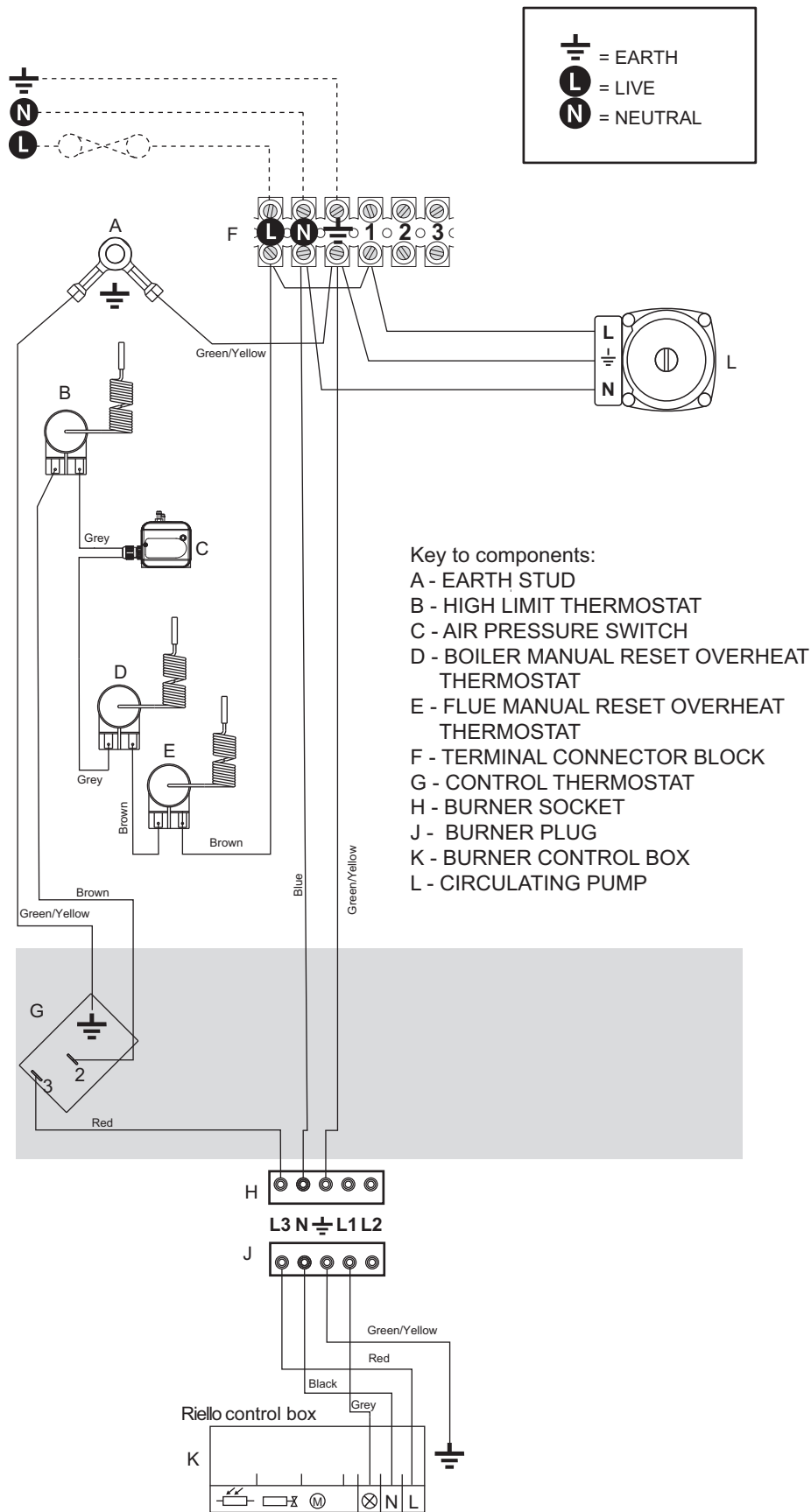

Fig. 55



**Utility System - 230V Standard wiring diagram**



6720809436-22.2Wo

Fig. 57

Utility - Remote 2 or 3 port valve control set using remote programmer

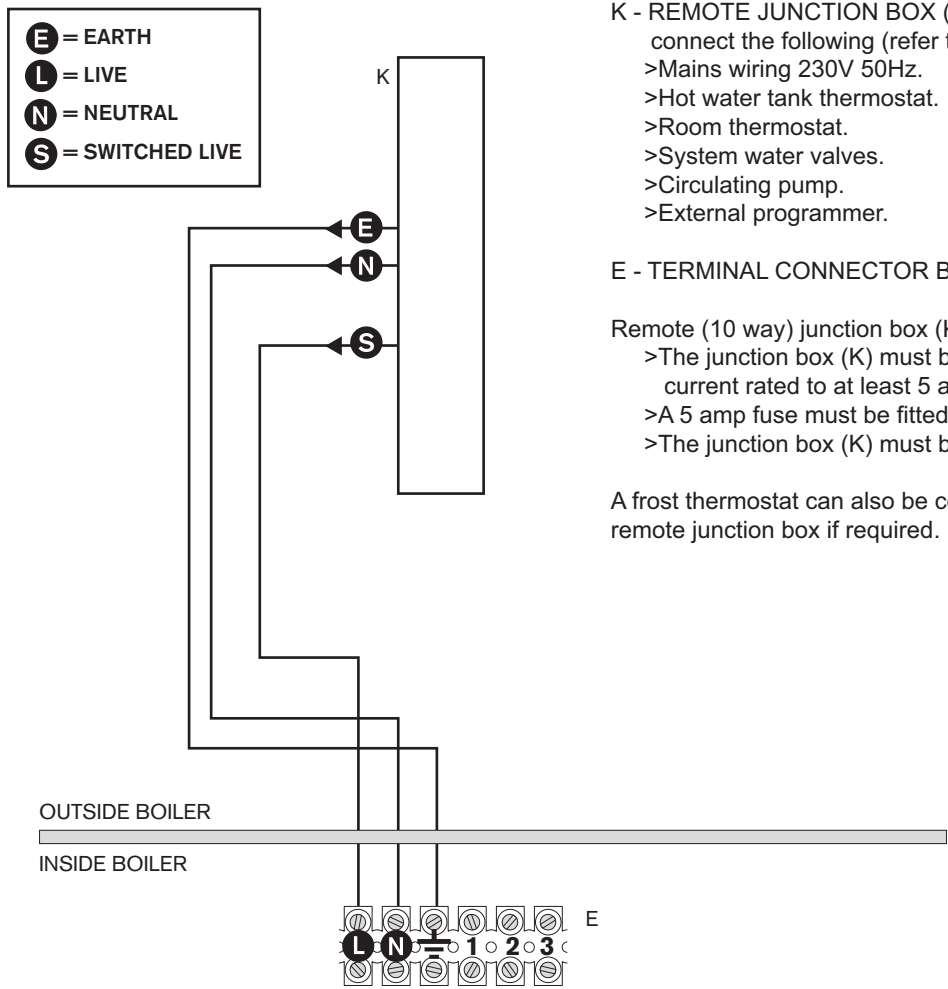

Key to components:

- K - REMOTE JUNCTION BOX (10-way) to connect the following (refer to manufacturers instructions):
  - >Mains wiring 230V 50Hz.
  - >Hot water tank thermostat.
  - >Room thermostat.
  - >System water valves.
  - >Circulating pump.
  - >External programmer.

E - TERMINAL CONNECTOR BLOCK.

Remote (10 way) junction box (K) requirements:

- >The junction box (K) must be a terminal block type, current rated to at least 5 amps.
- >A 5 amp fuse must be fitted to the mains supply.
- >The junction box (K) must be fitted externally to the boiler.

A frost thermostat can also be connected to the remote junction box if required.

6720809436-23.1Wo

Fig. 58

**Utility System - Remote 2 or 3 port valve control set using remote programmer**

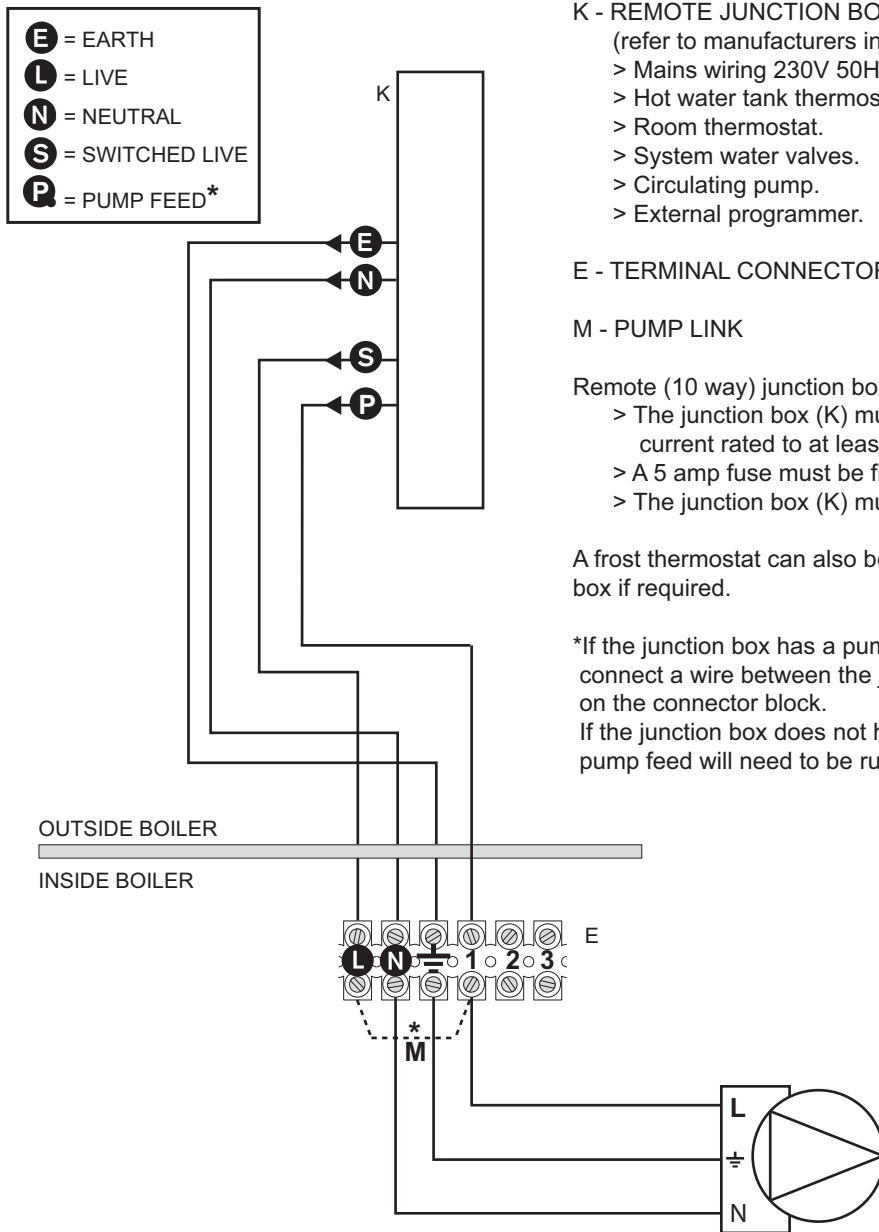

Key to components:

K - REMOTE JUNCTION BOX (10-way) to connect the following (refer to manufacturers instructions):

- > Mains wiring 230V 50Hz.
- > Hot water tank thermostat.
- > Room thermostat.
- > System water valves.
- > Circulating pump.
- > External programmer.

E - TERMINAL CONNECTOR BLOCK.

M - PUMP LINK

Remote (10 way) junction box (K) requirements:

- > The junction box (K) must be a terminal block type, current rated to at least 5 amps.
- > A 5 amp fuse must be fitted to the mains supply.
- > The junction box (K) must be fitted externally to the boiler.

A frost thermostat can also be connected to the remote junction box if required.

\*If the junction box has a pump overrun feature remove link (M) and connect a wire between the junction box pump feed and terminal 1 on the connector block.

If the junction box does not have a pump overrun feature no separate pump feed will need to be run to the boiler, leave link (M) in place.

6720809436-24.1Wo

Fig. 59

## 6 Commissioning

### 6.1 Pre-Commissioning checks - 18/25 Regular shown



**CAUTION:** 230 Volts

- ▶ Isolate the mains electrical supply before starting any work and observe all relevant safety precautions.

1. Check that the service and water pipes are connected correctly.
  - ▶ Check that all unused sockets are capped.
2. Check that the oil supply is Kerosene (Class C2) and that the pipework is connected correctly to the oil pump via the supplied flexible oil hose.
  - ▶ Check that the burner is seated correctly on its mounting flange and that the oil hose/s are routed correctly. See page 51, figure 90 for correct routing of the oil hose.
  - ▶ Turn on the main oil supply valve at the tank, check the oil supply pipework and connections. Rectify any leaks.
3. Check the flue is correctly fitted and the connections are secure.
4. Check the condensate pipework is correctly fitted and connected.
  - ▶ Check the condensate trap is filled with water.



**NOTICE:** If the boiler is not to be commissioned then:

- ▶ After successfully completing all of the checks and any rectification work, close the water valves, shut off the oil supply and electrically isolate the boiler.
- ▶ Complete the installation part of the Guarantee Registration Card, and complete a CD10 or equivalent to inform the LABC of the installation.
- ▶ Refit the top panel.

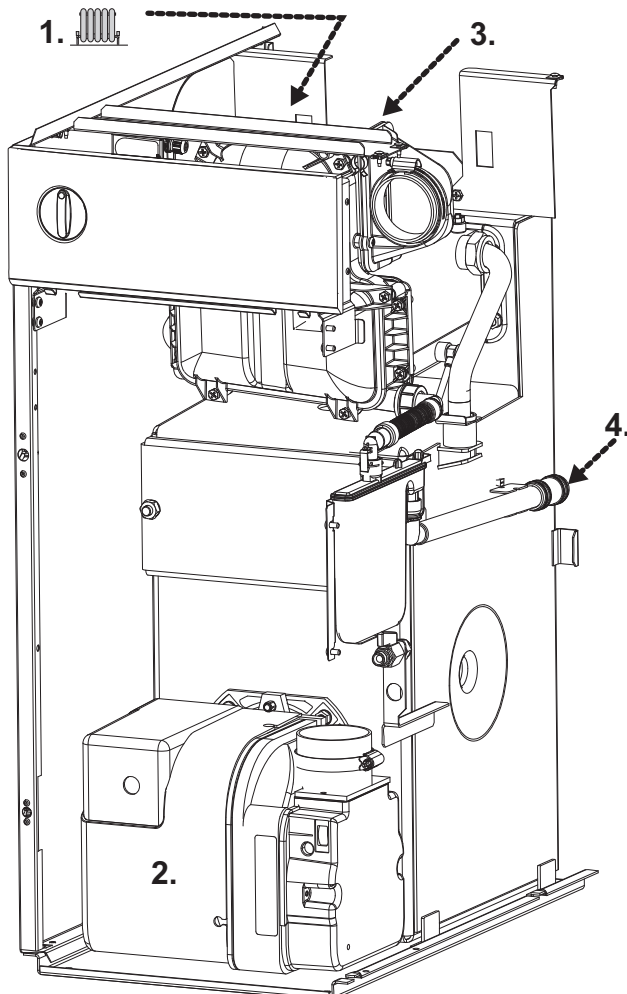



Fig. 60 Pre-Commissioning checks

### 6.2 Filling the system

- ▶ Open all system and radiator valves.
- ▶ Turn on the water main stop cock.
- ▶ Open vented systems only:
  - Turn on the water to the system feed and expansion cistern and allow the system to fill.
- ▶ Sealed systems only:
  - Check and if required, adjust the expansion vessel pressure using the Schraeder type valve.
- ▶ Fill the system to between 1 and 2 bar pressure via a WRAS approved filling link.
- ▶ Vent all radiators, retighten when completed.
- ▶ Monitor the pressure gauge during venting and repressurise if required.



**System boiler only**

The charge pressure of the built-in 10 litre expansion vessel is 0.5 bar as supplied, which is equivalent to a static head of 5 metres. At 1 bar pressure the vessel will provide 92 litres expansion capacity, the boiler has a primary water capacity of 20 to 22 litres and therefore additional system expansion capacity may be required.

- ▶ If an extra expansion vessel is fitted to the central heating return, adjust this to the same pressure as the appliance internal expansion vessel, refer to separate instructions supplied with the extra expansion vessel.

- ▶ Check the system and correct any leaks.
- ▶ Bleed air from at least one of the secondary heat exchanger air vents (a radiator key is ideal for this). There are two venting bosses [1] on the top of the secondary heat exchanger. Only one can be used if fluing to the side.

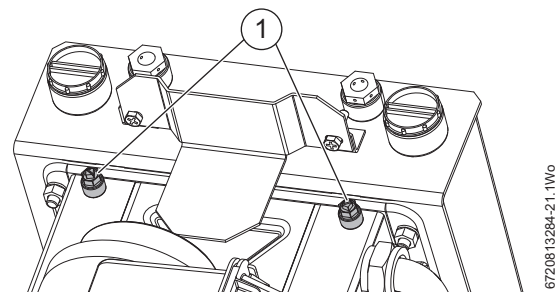

Fig. 61 Manual vent points

- [1] Manual vent points (each side of the secondary heat exchanger).

### 6.3 Water treatment

**NOTICE:**

- ▶ Salt based, softened water must not be used to fill the central heating system.

**Ensure that the system has been cleaned. Refer to section 4.1.2 of these instructions.**

#### Inhibitor (Central Heating)

- ▶ Check drain cocks are closed and all radiator valves are open before adding a suitable inhibitor or combined inhibitor/anti-freeze, if the system is exposed to freezing conditions, to the heating system water in accordance with the manufacturers instructions.

**i** The pH value of the system water must be between 6.5 and 8 or the appliance warranty will be invalidated.

- ▶ Fill system via a WRAS approved filling loop to between 1 and 1.5 bar.
- ▶ Vent all radiators; tighten vents when complete.
- ▶ Re-pressurise if necessary to 1bar.
- ▶ Set all controls to maximum.
- ▶ Record the date when the inhibitor was added to the system in the Boiler commissioning checklist and in the guarantee registration.

**NOTICE:**

- ▶ The concentration of inhibitor in the system should be checked every 12 months or sooner if system content is lost.
- ▶ In cases where all attempts to find a micro leak have failed, Worcester, Bosch Group supports the use of Fernox F4 leak sealer.

#### Water treatment products

Suitable water treatment products can be obtain from the following manufacturers:

ADEY	01242 546700 or <a href="http://www.adey.com">www.adey.com</a>
FERNOX	0330 100 7750 or <a href="http://www.fernox.com">www.fernox.com</a>
SENTINEL	01928 704330 or <a href="http://www.sentinelprotects.com/uk">www.sentinelprotects.com/uk</a>

### 6.4 Starting the appliance

**NOTICE:**

- ▶ Never run the appliance when the appliance/system is unpressurised (sealed systems) or empty.

1. Check the oil supply is correctly fitted, pressure tested and in good working order before turning on the oil supply valves to the boiler.
  - ▶ Turn on the main oil supply valve at the tank and draw off at least 2.5 litres of oil until a steady flow of clear uncontaminated oil can be seen as follows:
    - The oil supply to the boiler should be primed before the burner is operated to avoid unnecessary pump wear.
    - The use of an oil suction pump will prime and flush through any oil supply set up simply and easily, alternatively the following procedures can be used.

#### 6.4.1 Single pipe gravity feed system:

- ▶ Disconnect the flexible oil hose and open the isolating valve to discharge the oil into a suitable container.
- ▶ If a top entry tank has been used the pipework will need to be primed before the oil will discharge under gravity.
- ▶ When completed, close the isolating valve, reconnect the flexible oil hose.

#### When the oil reaches the pump, bleed the air from the pump:

- ▶ Open the isolating valve and the oil pump bleed port [1] to discharge into a suitable container once the boiler is started up.
- ▶ Switch on the electricity supply to the boiler.
- ▶ Set the programmer to ON for CH and DHW.
- ▶ Turn on the boiler CH control thermostat.
- ▶ Allow the burner to run through to lockout .

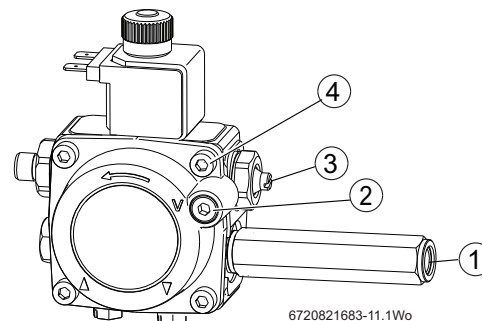

Fig. 62

- [1] Bleed and pressure gauge port
- [2] Vacuum gauge connection
- [3] Pressure adjuster
- [4] Cover retaining screws x4

#### If no oil comes out of the port valve [1], then re-prime the oil line as detailed above

- ▶ Wait 2 minutes then press the lockout reset button [K].
- ▶ Repeat the procedure until a steady stream of oil without air, runs from the bleed port, then lock bleed port [1].
- ▶ Switch off the boiler.

#### 6.4.2 Double pipe sub-gravity feed systems and single pipe suction lift with de-aerator:

- ▶ Prime the oil supply pipework to prevent oil pump damage.
- ▶ To prime a de-aerator [2], disconnect the flexible oil inlet hose [7] from the isolation valve and place in a container of heating oil [6]. Connect a spare flexible oil hose [5], to discharge into container [6]. Open the isolating valve, turn on the power to the boiler and set the programmer to ON. Prime the de-aerator until there is a steady flow of oil into container [6]. Turn off the boiler then reconnect the flexible oil inlet hose [7].
- ▶ Turn on the boiler, set the programmer to ON and turn the room thermostat up to create a demand for heat. The oil level in the de-aerator will drop whilst the oil is being drawn from the tank. If the de-aerator empties and the burner locks out before the oil is drawn from the tank, you will have to prime the de-aerator again.

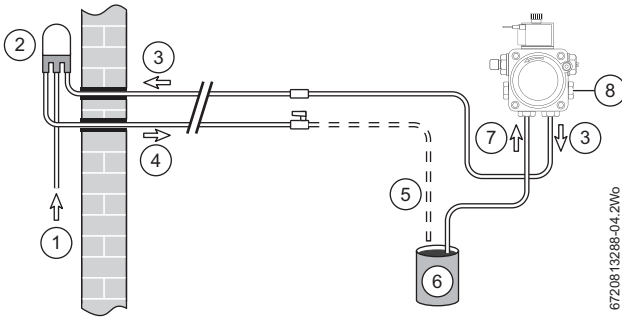

Fig. 63 Priming the pump

- [1] Oil supply
- [2] De-aerator
- [3] Return
- [4] Flow
- [5] Spare flexible oil hose
- [6] Container of oil
- [7] Oil pump flexible inlet hose
- [8] Bleed and pressure gauge port

- ▶ Switch off the boiler.
- ▶ Safely dispose of the container/dischage.

**6.4.3 Pump adjustments**

- ▶ Fit a suitable pressure gauge to port [3] on the oil pump.
- ▶ Switch on the boiler and set a heating demand.

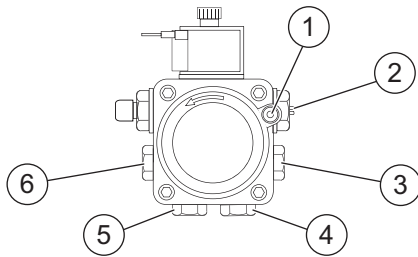

Fig. 64 Oil pump ports/connections

- [1] Vacuum gauge port
- [2] Pressure adjuster
- [3] Bleed and pressure gauge port
- [4] Return connection
- [5] Inlet connection
- [6] Auxiliary pressure gauge port

- ▶ Adjust the air shutter [3] → figure 65 and pump pressure [2] → figure 64 to the values shown in the table 10 on page 44. The burner should ignite following a pre-ignition period of approximately 15 seconds.
- ▶ If changing the burner output, check the position of the air damper disk [5] is correct to the output values shown in table 10.



Adjust position of air damper discs to suit burner output (see table 10 on page 44), located as shown in figure 65. Access by undoing the two screws [4] to release the air inlet cover.

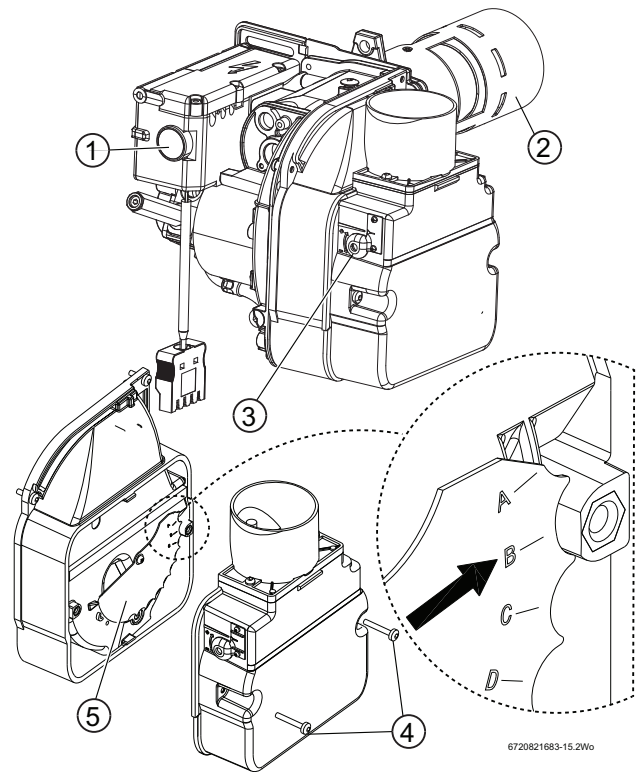

Fig. 65

- [1] Reset button
- [2] Blast tube
- [3] Air shutter adjuster
- [4] Captive screws air intake cover
- [5] Air damper disk

**6.4.4 Burner head setting**

Adjustments to the burner head are made on the basis of the required output, refer to table 10 for the required setting for your boiler.

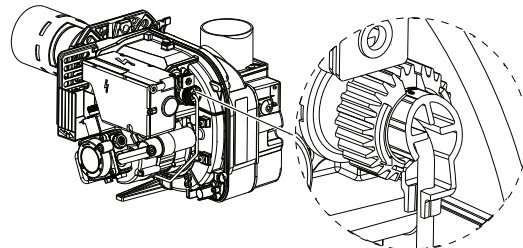

Fig. 66 Burner head adjustment thumbwheel

One complete rotation clockwise (cw) from the minimum position equals approximately one millimetre. Adjust the thumb-wheel to achieve the setting indicated in the table 10, according to your appliance model and output.

Using an engineer's rule or vernier gauge measure from the lip of the blast tube to the inside of the break plate as show in the figure below. Ensure that the break plate is level, check at four equal points to get an average of the required setting. The setting tolerance should be no more than  $\pm 0.25\text{mm}$

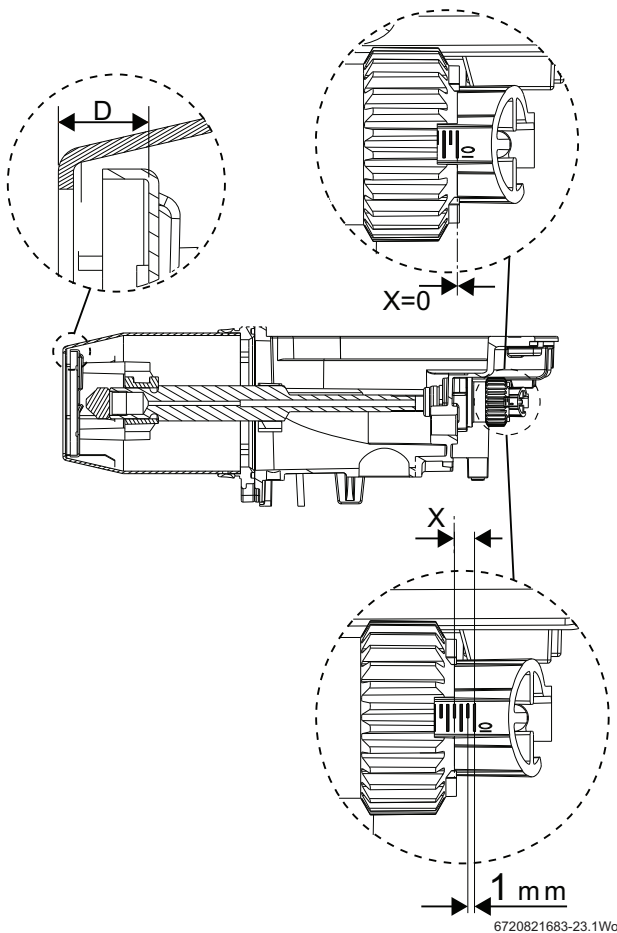

Fig. 67 Burner head adjustment

#### 6.4.5 Boiler lockout indicator on:

If the burner fails to establish a normal firing pattern or flame failure occurs the flame monitoring photocell mounted in the burner body will alert the burner control box to shut the burner down and provide a safe lockout state indicated by the illumination of the lockout indicator (D).

- ▶ Wait 2 minutes then press the lockout reset button D (→ figure 70) to initiate another start sequence.
  - ▶ Repeat procedure until a flame is established.
1. Start and run for 3 minutes then switch off.
  - ▶ Release the burner retainer nut (F).
  - ▶ Remove the burner.
  - ▶ Check for after-spurting from the nozzle, indicated by oil saturation on the combustion head (→ item G, figure 70).

If after-spurting occurs:

- ▶ Remove the combustion head (G) and electrodes, hold the burner vertical to unscrew the nozzle and fill the nozzle holder with kerosene.
- ▶ Refit nozzle, electrodes, combustion head (G) and the burner.
- ▶ Restart and run for 3 minute intervals until after-spurting stops.

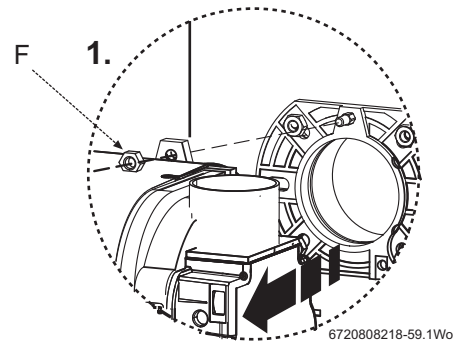

Fig. 68

#### 6.4.6 Combustion checks

- ▶ Start and run for 20 minutes
- ▶ Remove sampling point plug (K) to check the smoke reading is between 0-1. If the smoke level is above 1, check the combustion settings are correct and the oil nozzle is in good condition.

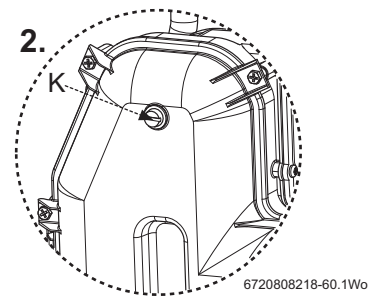

Fig. 69



Smoke readings may be inaccurate until the smoke from burning organic binder in the access door insulation has ceased.

- ▶ Check the CO<sub>2</sub> levels and adjust the air shutter (L) setting according to table 10.
- ▶ Check the flue gas temperature is close to the values shown in the table 10.



If the flue gas temperature is too high and the baffles are correctly fitted, then reduce the oil pump pressure (B) 5-10p.s.i. to compensate for nozzle variations.

- ▶ Turn off the electrical supply.
  - ▶ Isolate the oil supply to the burner.
  - ▶ Remove the oil pressure gauge.
  - ▶ Refit the blanking plug (A).
  - ▶ Check and rectify any oil leaks.
2. Switch on the oil supply.
    - ▶ Switch on the electrical supply.
    - ▶ Restart the boiler and run for 5 minutes.
    - ▶ Recheck the CO<sub>2</sub> levels and if required, adjust the air shutter setting (L) to obtain the correct CO<sub>2</sub> level.
    - ▶ Refit the sample point cap (hand tighten only, do not over tighten) and refit the burner cover.

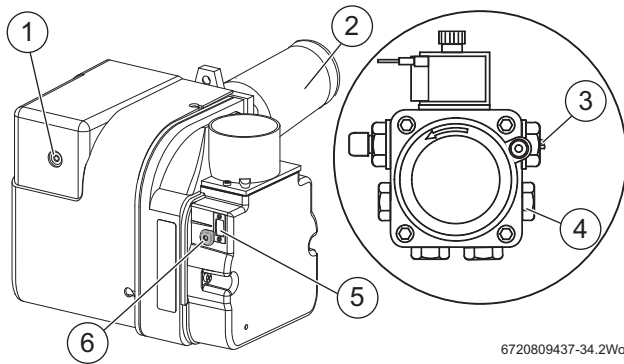

Fig. 70



**APPLIANCE MUST BE SET TO CO<sub>2</sub> LEVELS.**  
**AIR SETTINGS GIVEN ARE APPROXIMATE ONLY, AS FLUE LENGTH AND NOZZLE VARIATIONS WILL AFFECT THIS.**

**Nominal boiler rating at normal operating temperature using Kerosene (Class C2)**

Nozzle	Oil pump pressure bar	psi	Fuel flow rate Kg/h	l/h	Approx flue gas temp. °C	CO <sub>2</sub> %	Combustion head settings mm	Approx. air setting	Input (appliance) kW	Output (appliance) kW	Air damper disc setting	Flue damper required	Burner head
<b>Greenstar Danesmoor 12/18 model</b>													
0.40 x 80° EH	8.5	123	1.12	1.38	67	12.0	10.5	2.3	13.2	13.0	A	Yes	BX & recirculation tube
0.40 x 80° EH	10.0	145	1.30	1.60	70	11.5	11	1.75	15.3	15	B	Yes	BX & recirculation tube
0.50 x 80° EH	10.0	145	1.54	1.90	80	12.0	11.5	2.5	18.3	18.0	C	Yes	BX & recirculation tube
<b>Greenstar Danesmoor 18/25 model</b>													
0.50 x 80° EH	10.0	145	1.54	1.90	76	12.5	12.5	1.5	18.3	18.0	N/A	Yes	BX
0.60 x 80° EH	8.8	128	1.84	2.28	81	12.5	14	2.25	21.9	21.5	N/A	Yes	BX
0.65 x 80° EH	9.5	138	2.15	2.66	90	12.5	15	3.25	25.5	25.0	N/A	Yes	BX
<b>Greenstar Danesmoor 25/32 model</b>													
0.65 x 80° EH	9.8	142	2.15	2.66	79	11.5	19	3.5	25.5	25.0	N/A	No	BX
0.75 x 80° EH	10.3	150	2.46	3.04	84	12.0	19	4.25	29.1	28.5	N/A	No	BX
0.85 x 80° EH	10.0	145	2.78	3.44	85	12.5	19	4.75	32.7	32.0	N/A	Yes <sup>1)</sup>	BX

Table 10 Combustion settings

1) Internal boilers with flues less than 4 metres

### 6.4.7 Central heating

1. Open all radiator valves.
  - ▶ Set room thermostat to maximum.
  - ▶ Set programmer to ON for CH, OFF for DHW (if applicable).
  - ▶ Turn the thermostat control (A) to max.
- ▶ Ensure all radiators are heating up evenly and balance the system to the temperature difference required for the heating flow and return according to the heating load.

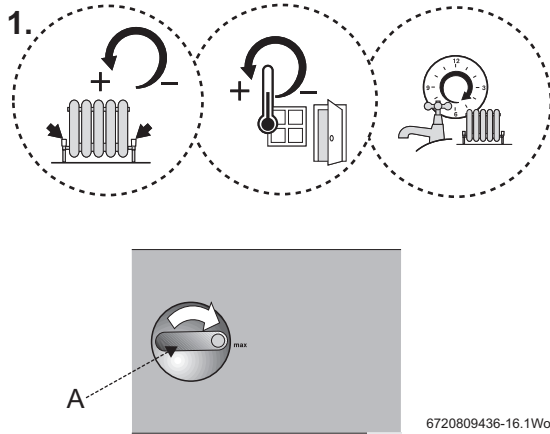

Fig. 71

2. Set the room thermostat to minimum.
  - ▶ Check that any other controls that are fitted to the system are operating properly.

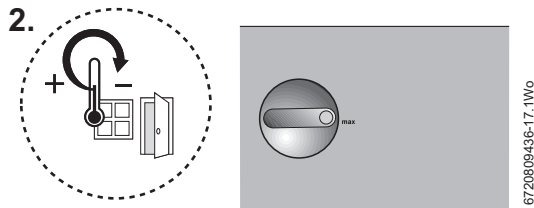

Fig. 72

### 6.5 Finishing commissioning

- ▶ Pivot the control box (A) figure 74 up and into the boiler. Secure with screws (B).

#### Utility system only:

Refer to figure 73

- ▶ Slide the expansion vessel up and locate the top edge into the bracket [1] located under the control panel.
- ▶ Push the expansion vessel in until the bracket on the expansion vessel aligns with the bracket on the cross member.
- ▶ Secure with the screw [2] removed earlier.

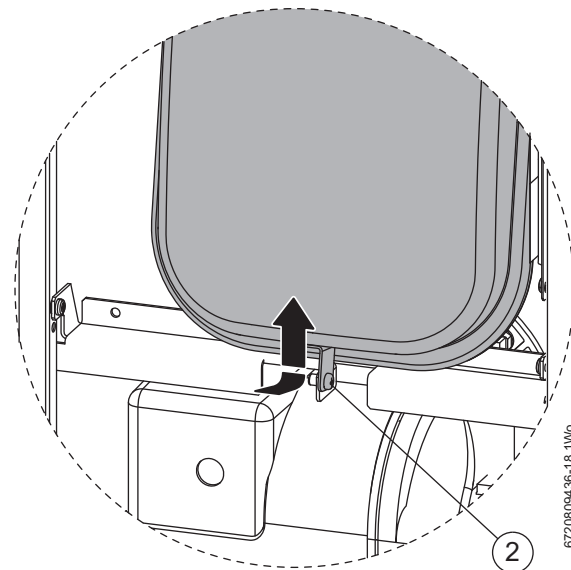
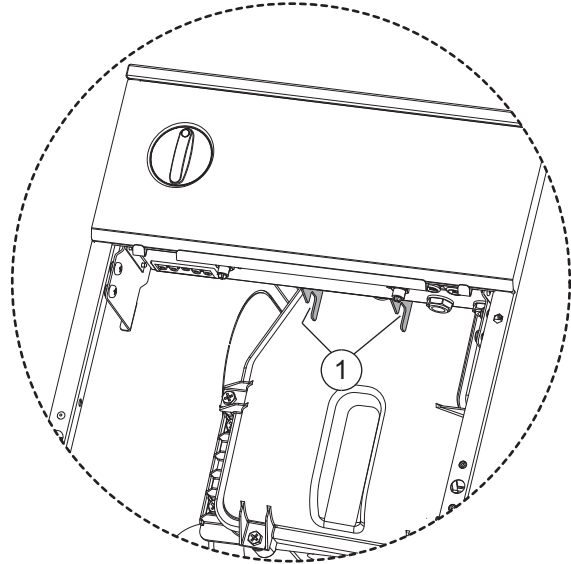

Fig. 73 Expansion vessel location

- ▶ Locate the front panel (C) by aligning the ball studs with the retaining slots (E) and secure near the top and at the bottom by gently pushing home the ball studs into the retaining slots (E). Remember always to apply pressure at the edges of the panels to avoid damage.
- ▶ Locate the top panel (F) onto the rear brackets (G) and press down to secure the ball stud connections (H). Always apply pressure at the edges of the boiler panels when securing to avoid accidental damage.

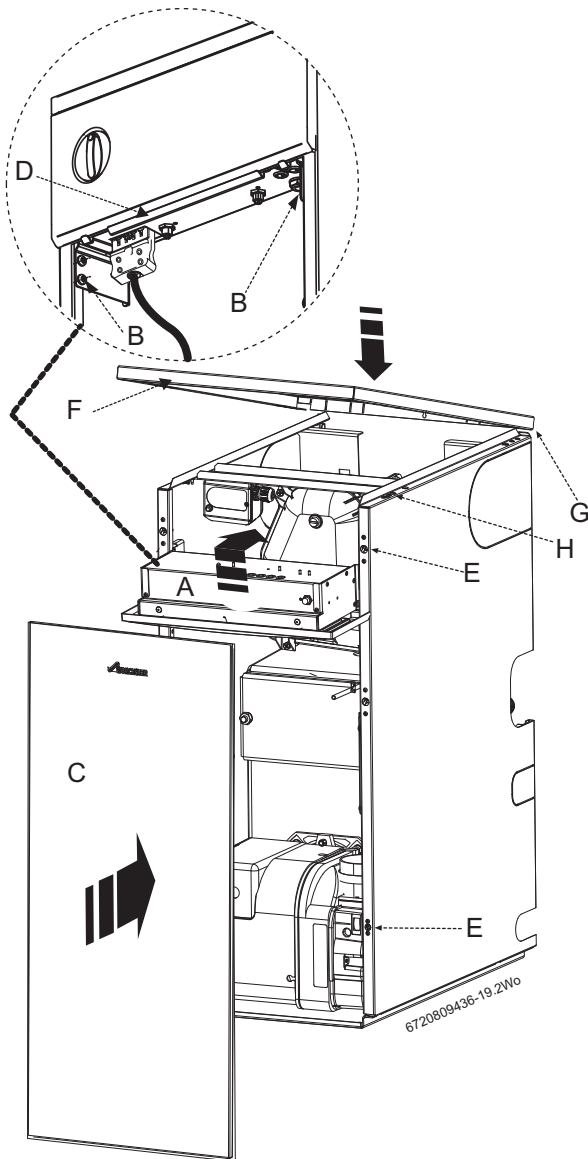

Fig. 74

### 6.5.1 Hand over

- ▶ Complete the Boiler commissioning checklist at the back of this manual and CD11 or an equivalent commissioning form.
- ▶ Set up the controls and show the customer how to operate all the controls shown in the User Guide plus any external controls.
- ▶ Instruct the customer on:
  - Sealed systems: The need to re-pressurise the appliance occasionally and the pressure expected at the pressure gauge.
  - Sealed systems: Location of the filling loop and system pressure gauge.
  - Sealed systems: The use of the filling loop and how to re-pressurise the system.
  - How to use the TRVs.
  - How to reset the appliance.
- ▶ Show the customer the fault finding information in the User guide.
- ▶ Show the customer where the serial number/appliance information is when they call in with a problem (Boiler commissioning checklist at the rear of the manual).
- ▶ Give the customer details of how to contact the installer/emergency numbers.
- ▶ Show the customer how to safely isolate the appliance.
- ▶ Advise the customer where they can find information on the Worcester, Bosch Group website [www.worcester-bosch.co.uk](http://www.worcester-bosch.co.uk).
- ▶ Advise the customer that the varying external temperatures will affect the output of the appliance, especially the DHW.
- ▶ Ensure that the User Guide and Installation, Commissioning and Service manual, with the Boiler commissioning checklist and service record, is left with the appliance or homeowner.
- ▶ If the appliance is unused and exposed to freezing conditions, shut off all the mains supplies and drain the system and appliance, label accordingly.
- ▶ Show the customer the location of the condensate pipe run for external/unheated areas that maybe at risk of prolonged cold temperatures.

### 6.5.2 Appliance guarantee

This appliance has a guarantee against faulty materials or workmanship for a period from the date of installation subject to the following terms and conditions:

- During the period of this guarantee any components of the appliance which are proven to be faulty or defective in manufacture will be exchanged or repaired free of charge by Bosch Thermotechnology Ltd.
- The householder may be asked to prove the date of installation, that the appliance was correctly commissioned and, where appropriate, the first year's service has been carried out to the satisfaction of Bosch Thermotechnology Ltd., when requested. These should be documented as a part of the Boiler commissioning Checklist.
- The appliance has been used only for the normal domestic purposes for which it was designed.

This guarantee does not affect your statutory rights.

### Guarantee registration

Your Greenstar appliance carries a guarantee against faulty material or manufacture subject to Terms and Conditions.

Guarantee Registration can be completed:

- On-line
  - You can register on our website:  
www.worcester-bosch.co.uk/guarantee
- By phone
  - You can register by ringing 0330 123 2552
- By post
  - Please send your completed form to:  
Worcester, Bosch Group, Cotswold Way, Warndon, Worcester,  
WR4 9SW.

To read the full Terms & Conditions please visit us on-line at  
www.worcester-bosch.co.uk/guarantee.

Your statutory rights are not affected by the manufacturer's guarantee.

## 7 Service and Spares

### 7.1 Inspection and service - 18/25 Regular shown

	<p><b>CAUTION: MAINS SUPPLIES</b></p> <p>▶ Isolate the water, electricity, and oil mains supplies before starting any work and observe all relevant safety precautions.</p>
---	---

#### Routine servicing

To maintain efficient boiler operation, the following should be carried out at least once a year, carry out a pre-service check and note any operational faults.

### 7.2 Pre-service checks

1. Pull front panel (A) forward from the bottom and near the top disengaging the ball studs from their connections (B) to remove.

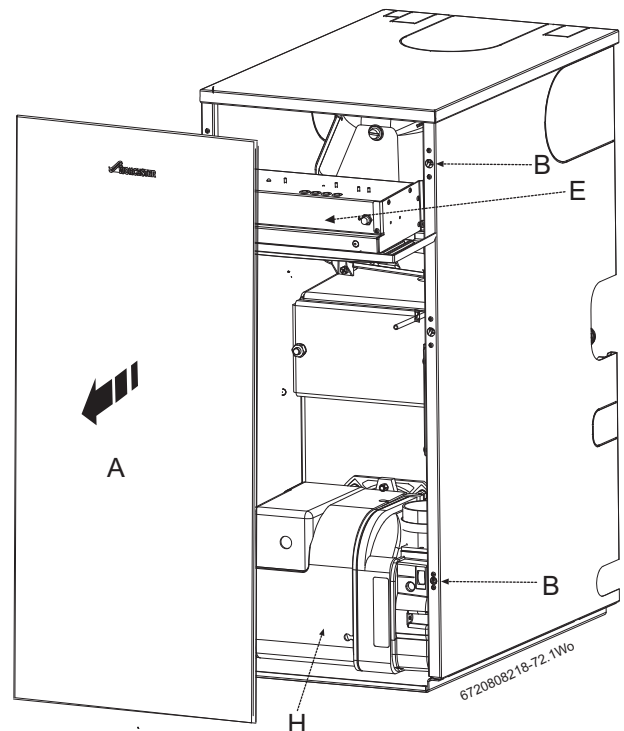

Fig. 75 Access to internal components

#### Utility system only:

- ▶ In the case of the Utility system boiler, remove the retaining screw [1] at the base of the expansion vessel.
  - ▶ Pull the expansion vessel forward slightly and down to remove. Place the expansion vessel outside of the boiler, taking care not to kink or stretch the flexible hose.
2. Remove securing screws (D) from each side of control box (E).
    - ▶ Pivot control box (E) downwards into the service position as shown. Operate the appliance and system and note any faults which may need to be corrected during the service.
    - ▶ Switch off and electrically isolate the boiler.

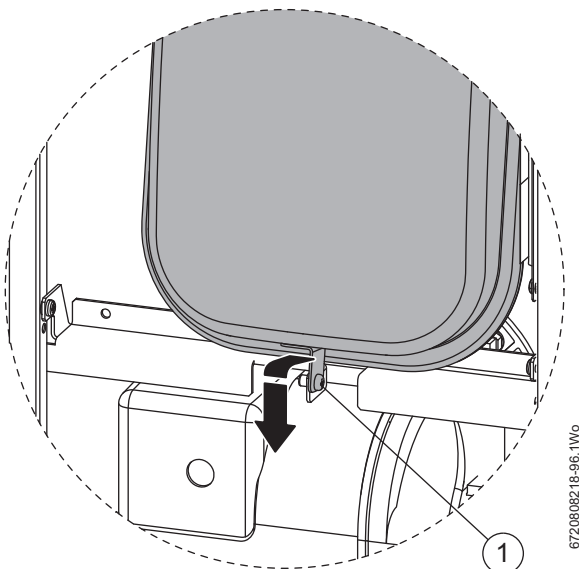

Fig. 76 Expansion vessel removal

3. Unplug burner lead (F) from control box.

2. & 3.

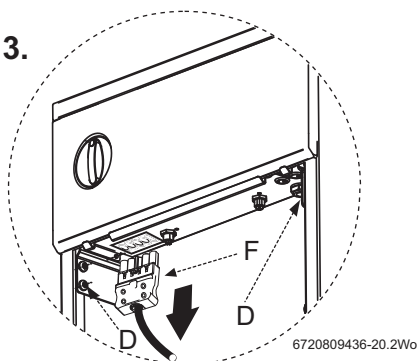

Fig. 77 Burner lead

4. Loosen clip (G) to detach air duct pipe from burner (H).

► Unscrew burner retainer nut (I) and gently pull burner forward so that the retainer (J) is free of the lug (K).

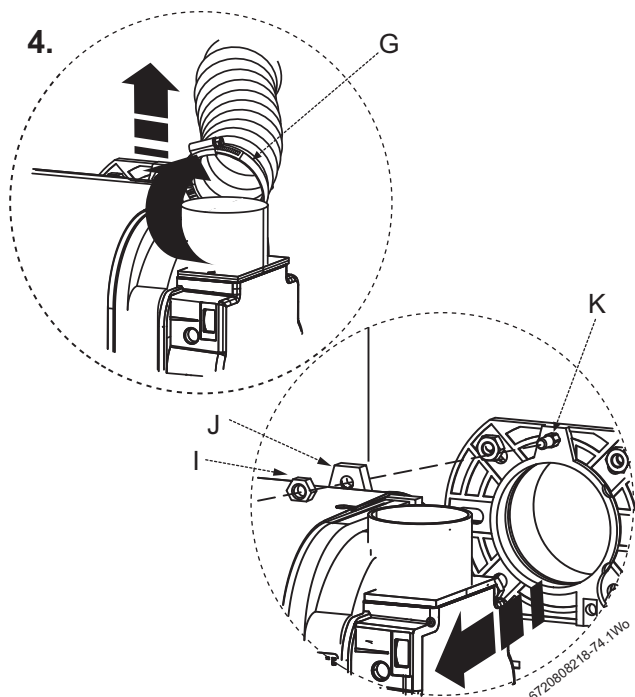

Fig. 78 Burner removal

### 7.3 Service requirements

See the following instructions for detail of some of the service requirements listed below:

- Check and clean the burner.
- Replace the burner nozzle and flexible oil pipe/s.
- Check and clean the baffle retainers.
- Check and clean the baffles.
- Check that the flue damper is correctly fitted, if required.
- Check and clean the heat exchangers surfaces.
- Check the combustion chamber access door insulation board.
- Check that the flue system is unobstructed and clean as necessary.
- Clean or replace all oil filters.
- Check that the condensate system is not obstructed, clean and refill the condensate trap.

### 7.4 Sealed system only

The PRV is a safety device and must be checked for correct operation. The expansion vessel pressure must also be checked and adjusted if required.

### 7.5 Clean the burner

- Remove the two hex head screws [1] and remove the air intake cover [2] and clear any debris from the air intake and air shutter.
- Remove the four screws [3] and remove the suction inlet [4] to gain access to the fan.
- Clean both sides of the fan and suction inlet cover with a brush and compressed air.
- Check the condition of the gaskets between these parts and replace if necessary.
- Note the position of the air shutter adjustment and check the air shutter moves freely.
- Check that the fan rotates freely.
- Reassemble the components.

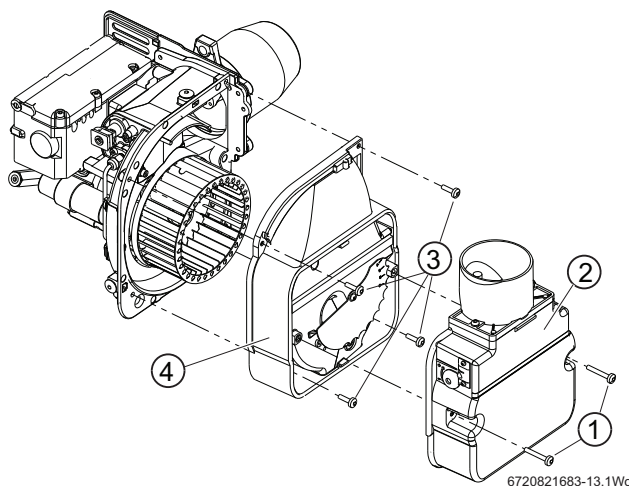

Fig. 79 Fan access

### 7.6 Oil burner nozzle

Before removing or fitting a new nozzle refer to figure 80:

- Remove the screws [1] from the blast tube [2] and remove the blast tube



There is a recirculation tube fitted to the 12/18 models, this does not need to be removed from the blast tube

- Unplug the HT leads [4]
- Loosen the screw [3] securing the break plate [5] and slide the unit off

- ▶ Use a suitable spanner to stop the nozzle body turning
- ▶ Remove the nozzle [8] and secure the new nozzle, hand tight
- ▶ Tighten the nozzle utilising the two spanners used during removal, do not over-tighten

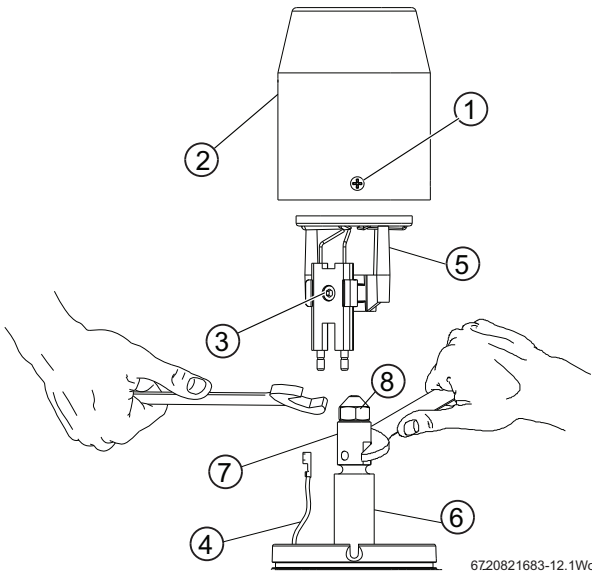

Fig. 80 Nozzle access

Refer to figure 81 Photo cell alignment

- ▶ Refit the break plate [5] ensuring that the break plate is pushed fully on to the nozzle holder [6].
- ▶ To align the hole [9] in the break plate with the photocell, ensure that the fixing screw [3] is located fully in the seating [7] provided in the nozzle holder [6].

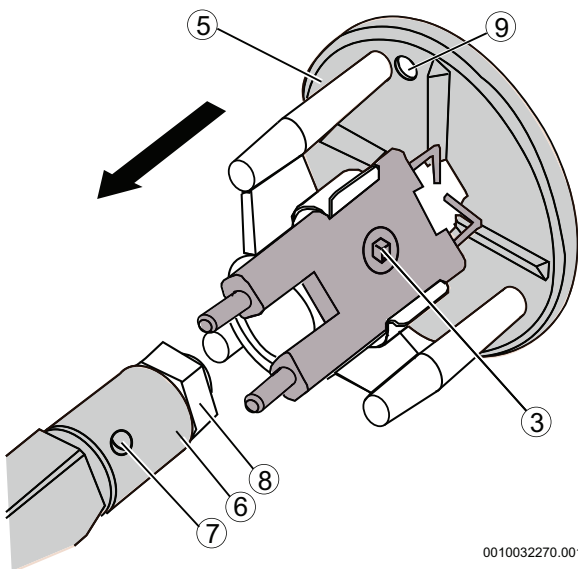

Fig. 81 Photocell alignment

- ▶ Reconnect the HT leads [4]
- ▶ Refit the blast tube [2] and secure with the screws [1]

Refer to figure 82:

- ▶ Check that the nozzle [1] and the electrode [2] alignment settings are correct.
- ▶ Ensure that the nozzle [1] is aligned centrally within the combustion head [3].
- ▶ Inspect for any visible defects.

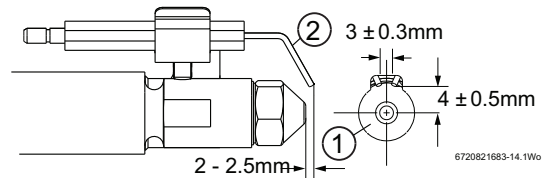

Fig. 82 Nozzle and electrode alignment

### 7.7 Pump filter

- ▶ Refer to figure 83 and remove the oil pump internal filter, clean in Kerosene and reassemble.

The internal filter is accessed by removing screws [1] and the oil pump cover [2].

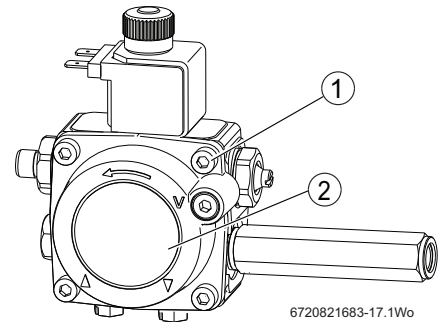

Fig. 83 Pump filter access

- ▶ Replace the standard flexible oil line/s at every annual service to prevent the possibility of leakage due to ageing.
- ▶ Reassemble the burner components.
- ▶ Check the O-ring seal located around the combustion head and replace if necessary. This seal must be in good condition, seal failure will cause flue gases to escape into the room.

### 7.8 External oil filter

- ▶ Remove the paper element from the external oil filter and replace it. If the filter contains a washable element, thoroughly clean in Kerosene and reassemble into the filter.

### 7.9 Combustion chamber - 18/25 Regular shown

- ▶ Release the M10 retaining nuts and washers (A) and remove baffle/combustion chamber access door (B).
- ▶ Check the fibreglass rope seal on the baffle/combustion chamber access door (B) and replace if necessary.
- ▶ Remove the one piece baffle set (C), clean and check the condition. Replace if considered to be badly corroded/degraded.
- ▶ Thoroughly clean all of the heat exchanger surfaces using a suitable brush and clear all loose debris from the combustion chamber.
- ▶ Check the condition of the baffle/combustion chamber access door insulation. If the insulation is damaged the door assembly must be replaced.
- ▶ Ensure one piece baffle set [C] is in the right location, correctly resting on the baffle rests [D] on either side of the combustion chamber and pushed securely into place. Baffle sets for the 18/25 and 25/32 boilers are identified with tabs on the front and rear edge
- ▶ Refit baffle/combustion chamber access door (B).
- ▶ Secure with nuts and washers (A) and tighten until the door is firmly secured. Do not over tighten the nuts.

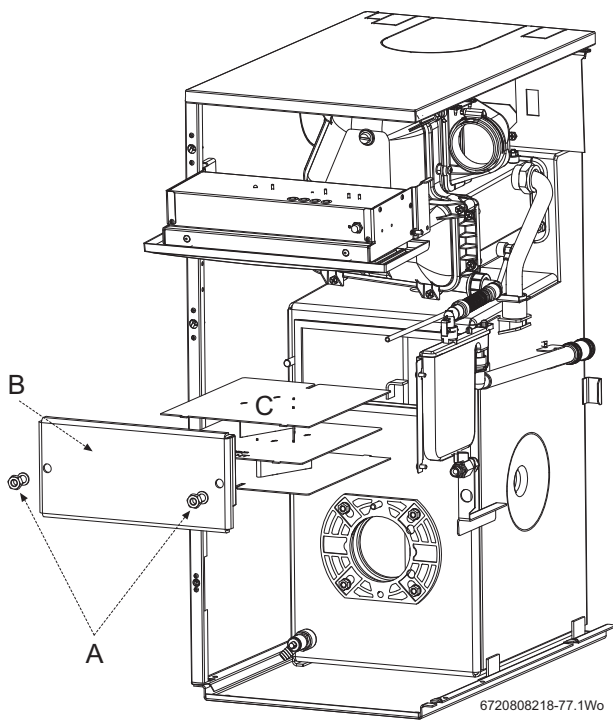

Fig. 84 Combustion chamber

**i** 18/25 and 25/32 baffle are identified with tabs on the front and rear edges

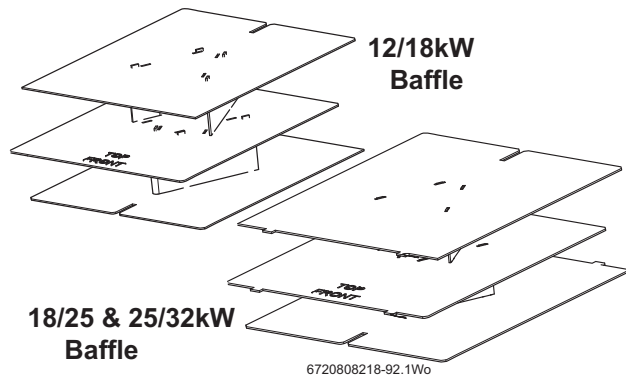

Fig. 85 Baffle detail

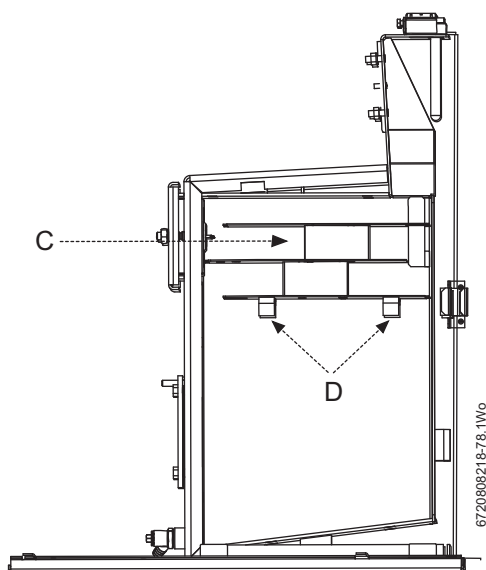

Fig. 86 Baffle positioning

### 7.10 Oil supply system and tank

- ▶ The oil pipeline, filters, fire valve and tank should be inspected and maintained in accordance with OFTEC regulations.

### 7.11 Clean the boiler - Manifold access

Refer to figure 87.

- ▶ Release screws [1] to remove the flue manifold access cover [2] and clear any debris.
- ▶ Check the flue system and clean if necessary.
- ▶ Remove the baffle retainer [3] and baffles [4] from the secondary heat exchanger.
- ▶ Check and clean the secondary heat exchanger surfaces.



Do not use wire brushes or cleaning agents to clean the stainless steel secondary heat exchanger components.

- ▶ Check the condensate route [5] is clear.
- ▶ The condensate trap [7] should be removed and cleaned.
- ▶ Release the pipe locking tab [8] and disconnect the flexible pipe [9] from the top of the trap and move the flexible pipe up away from the trap.
- ▶ Release the trap locking tab [10] and move the trap up and back to remove from its mountings.
- ▶ Clean the trap by flushing with water.
- ▶ Check the O ring seals and replace if necessary, grease the seals with a solvent free grease.
- ▶ Refit the trap making sure that the locking tabs are locked in place.
- ▶ Pour 500 ml of water into drain [5] to refill the condensate trap and check that the condensate discharge pipe is discharging.
- ▶ Clean the secondary heat exchanger baffles [4] if necessary and refit correctly.
- ▶ Refit the baffle retainer [3].
- ▶ Check and clean the flue damper, ensure that it is correctly fitted
- ▶ Check the seal on the manifold access cover [6] and replace if necessary.
- ▶ Refit the flue manifold access cover [2] and secure with screws [1].

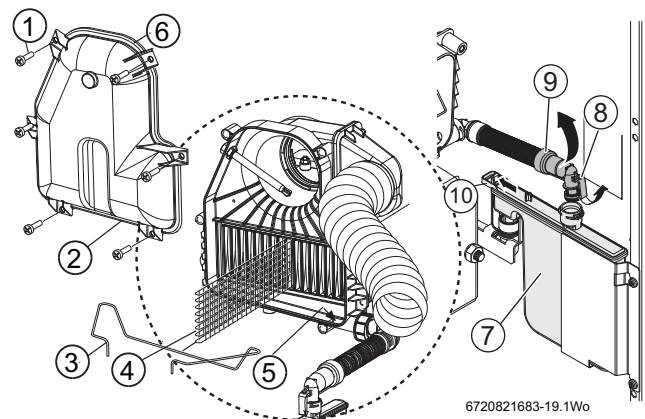



Fig. 87 Secondary heat exchanger and condensate trap detail

## 7.12 Re-commissioning the burner



**WARNING: Flue gas leakage**  
The seal between the burner and the mounting flange must form a gas tight seal to prevent leakage of potentially dangerous gas from the combustion chamber.

- ▶ Unless the burner is level when pushing the burner into the flange the O-ring may not seat properly allowing flue gas to escape!
- ▶ Always check that the O-ring seal (Fig 88item A) is in good condition before fitting the burner. Replace the O-ring seal if defective.

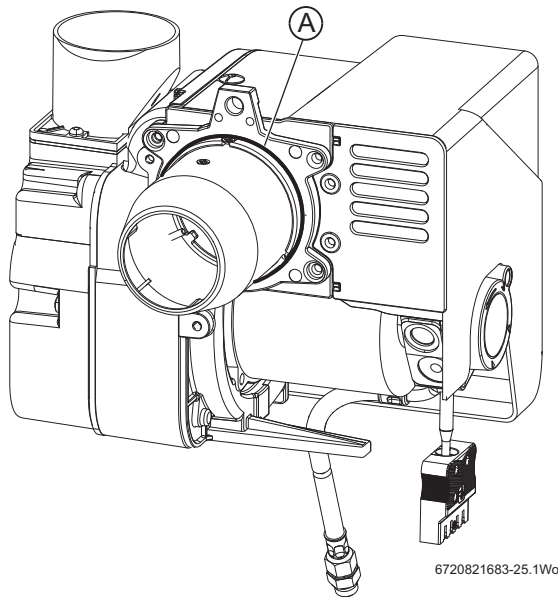

Fig. 88 18/25 and 25/32 Burner O-ring seal shown

1. Align burner combustion head into burner collar.
  - ▶ Locate the burner retainer [A] over the threaded lug on the collar [B], ensure that the burner is level and push the burner firmly onto the flange ensuring the O-ring seal is fully engaged. Support the burner in position and secure with the retaining nut [C]. Tighten sufficiently to hold the burner but do not over tighten.
  - ▶ Check that the burner is seated correctly on its mounting flange and that the oil hose/s are routed correctly as shown in Fig. 90 and not trapped in front of or underneath the burner.
  - ▶ Attach air duct pipe and tighten clip (D) to secure to the burner air intake.

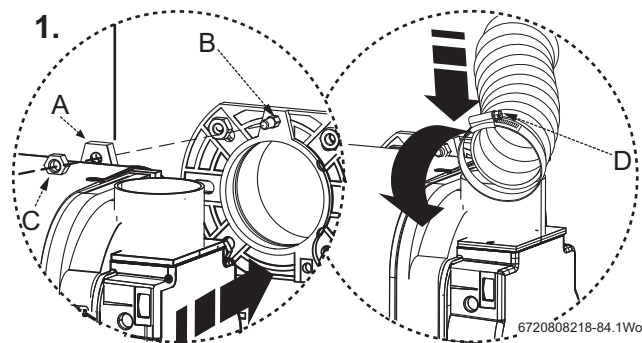

Fig. 89 Refitting the burner

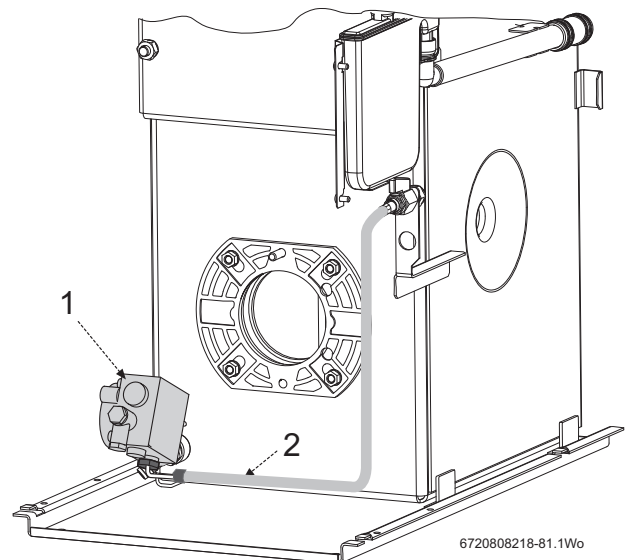

Fig. 90 Oil pump and hose detail

- [1] Oil pump
  - [2] Flexible oil hose route. Ensure that the rigid 90° connection at the pump points to the right when the boiler is viewed from the front and the flexible hose follows the route as show in the figure above.
2. Swing control box back up into operating position and retain in place by replacing the two securing screws (E) in the bottom locations.
    - ▶ Plug burner lead (F) into control box.
    - ▶ Connect an oil pressure gauge to the oil pump, run the burner and check the oil pressure is correct for the required boiler output. Check that the smoke reading is between 0 - 1. If above 1 check the air setting. If the air setting is correct check that the burner has been reassembled correctly.
- Allow the boiler to warm up then check the combustion settings are correct as indicated in table 10 on page 44, ensure CO<sub>2</sub> levels are correct. Adjust the air shutter if necessary see page 44, figure 70 for details.
- When the combustion is correct turn off the boiler, remove the pressure gauge and refit the blanking plug and plastic cover.
3. Locate the front panel by aligning the ball studs with the retaining slots and secure near the top and at the bottom by gently pushing home the ball studs into the retaining slots (I). Remember always to apply pressure at the edges of the panels to avoid damage.

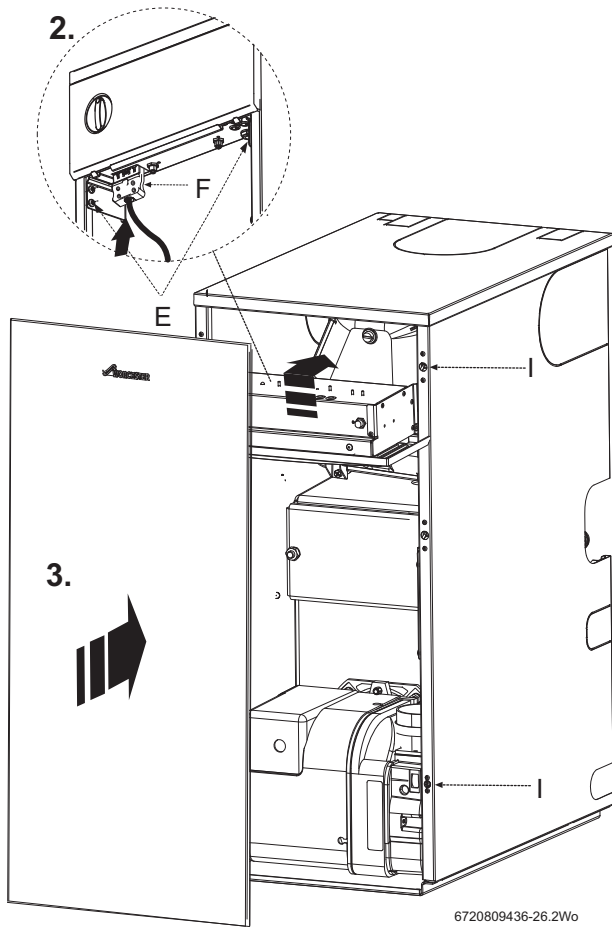

Fig. 91 Refitting panels

### 7.13 After service hand over

- ▶ Make a note of the date of any water treatment.
- ▶ Set the controls back to the users requirements.
- ▶ Complete the service interval record at the back of this manual and a CD11 or an equivalent form.
- ▶ If the appliance is unused and exposed to freezing conditions; shut off all the mains supplies, isolate the boiler and drain the system and boiler, including the secondary heat exchanger.

### 7.14 Spares

For Worcester Bosch spares refer to the the website at [www.worcester-bosch.co.uk/spares](http://www.worcester-bosch.co.uk/spares)

## 8 Fault finding and diagnosis

### 8.1 Burner functions

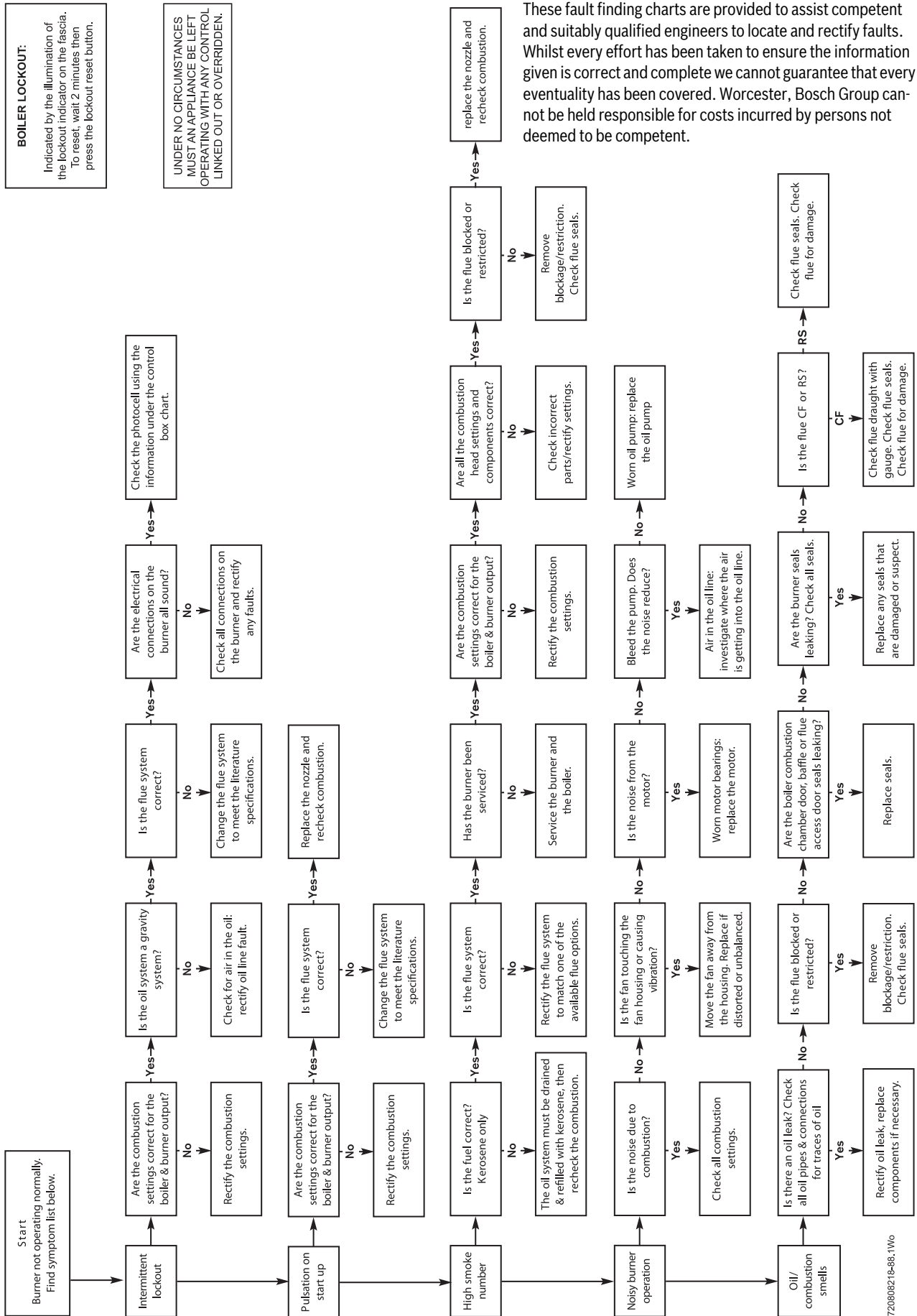

These fault finding charts are provided to assist competent and suitably qualified engineers to locate and rectify faults. Whilst every effort has been taken to ensure the information given is correct and complete we cannot guarantee that every eventuality has been covered. Worcester, Bosch Group cannot be held responsible for costs incurred by persons not deemed to be competent.

## 8.2 Heating and hot water

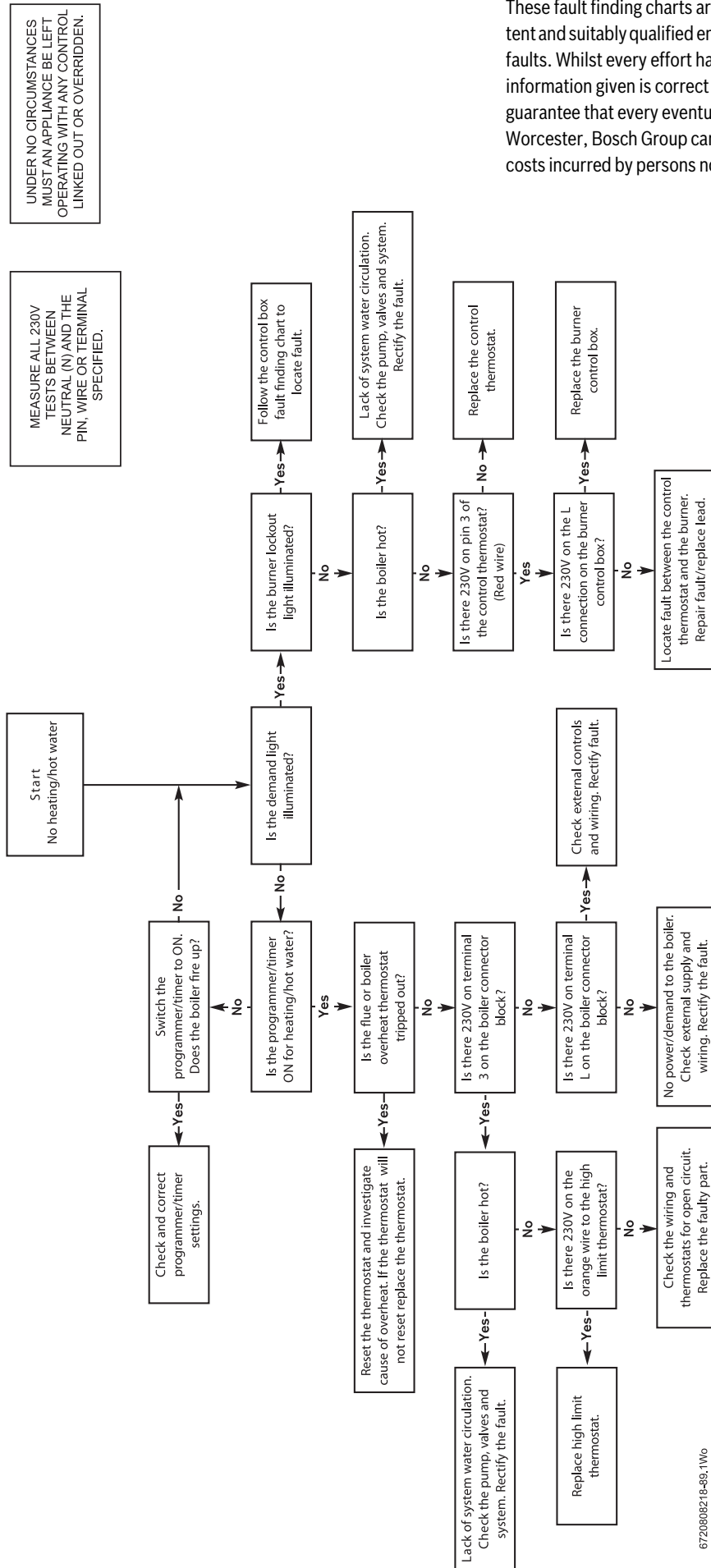

These fault finding charts are provided to assist competent and suitably qualified engineers to locate and rectify faults. Whilst every effort has been taken to ensure the information given is correct and complete we cannot guarantee that every eventuality has been covered. Worcester, Bosch Group cannot be held responsible for costs incurred by persons not deemed to be competent.

6720808218-98.1W6

**8.3 Boiler function**

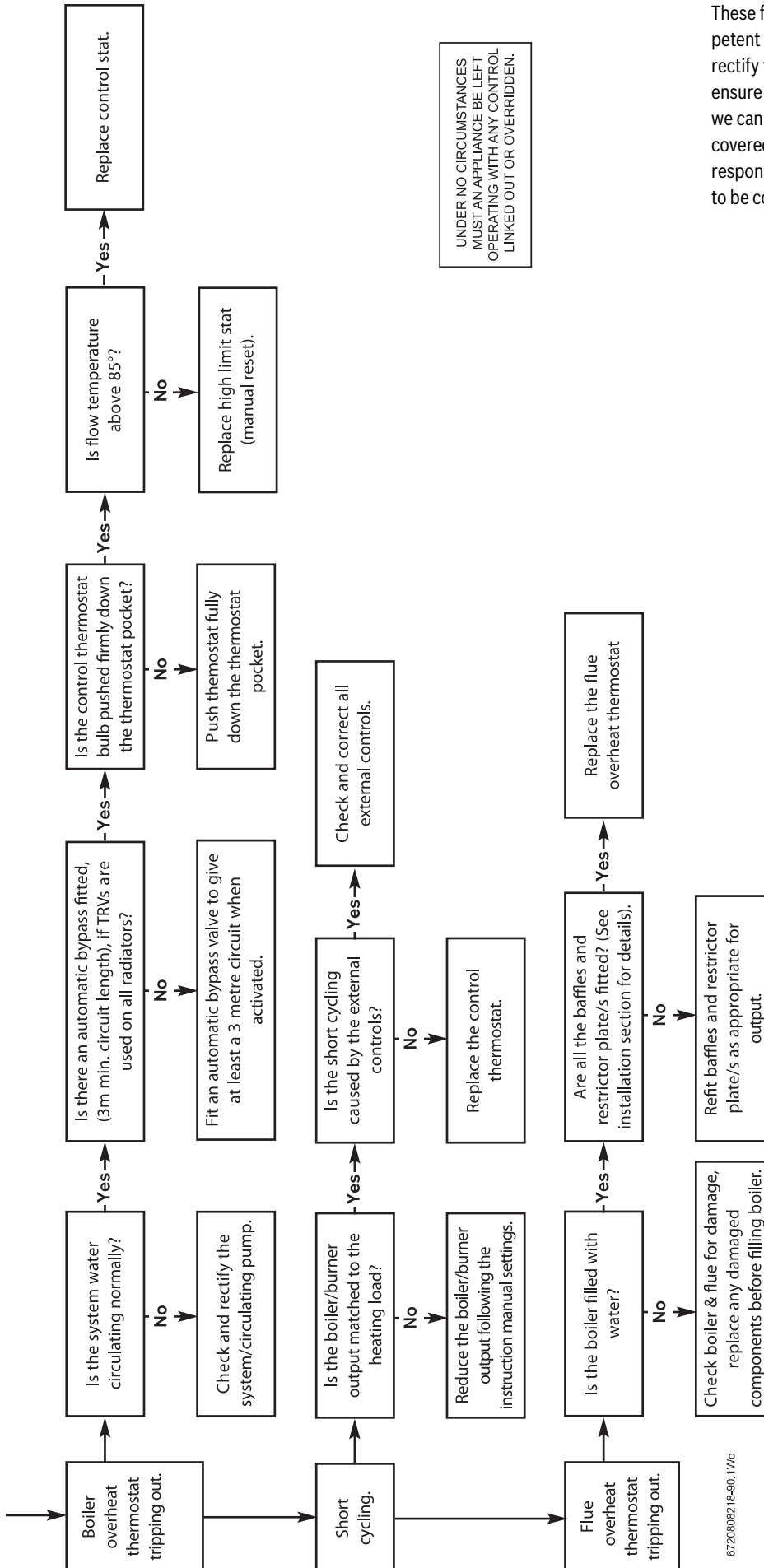

UNDER NO CIRCUMSTANCES MUST AN APPLIANCE BE LEFT OPERATING WITH ANY CONTROL LINKED OUT OR OVERRIDDEN.

These fault finding charts are provided to assist competent and suitably qualified engineers to locate and rectify faults. Whilst every effort has been taken to ensure the information given is correct and complete we cannot guarantee that every eventuality has been covered. Worcester, Bosch Group cannot be held responsible for costs incurred by persons not deemed to be competent.

67208027.18-90.1W6



## 8.5 Riello control box 12/18 model

### 8.5.1 Last lockout memory feature

The control box allows the last lockout that happened to be displayed. Access to this function is possible in both STANDBY and OPERATING status.

- Keep the button pressed for 25 seconds = t < 30 seconds

### 8.5.2 Control box LED codes

Lockout types (burner in lockout)	
<b>RED steady ON</b> Lockout for no flame after safety time	[3]
<b>RED 0.5 seconds ON/ RED 0.5 seconds OFF</b> Lock out for false flame signal	[5a]
<b>RED 0.2 seconds ON /RED 0.2 seconds OFF</b> Lock out for maximum number of flame loss re-lights	[9]
<b>RED 2.5 seconds ON / ORANGE 0.5 seconds ON</b> Lock out for fan motor failure	[3d]
<b>RED 2.5 seconds ON / GREEN 0.5 seconds ON</b> Lock out for oil valve circuit driver failure	[8c]
<b>ORANGE 0.5 seconds ON / GREEN 0.5 seconds ON</b> Lock out for EEPROM failure	Replace control box
<b>Red 0.5s ON / Red 2.5s OFF</b> Max pre-heat time exceeded (10 minutes)	[2]

Table 11

- Release the button.  
LED displaying the type of lockout memorised for 10 seconds  
The time displaying the type of lockout can be extended by pressing the reset button again during the display of the lockout (the lock out display continues for another 10 seconds)

Anomaly types (Burner in stand-by)	
<b>Green 0.5 s ON / Green 2.5 s OFF</b> Pre-heating time	Fit pre-heat link
<b>Green 0.5s ON / RED 0.5s ON</b> Extraneous light	Lock out after 25s
<b>Orange steady ON</b> Abnormal frequency supply	When an anomaly appears during: <ul style="list-style-type: none"> <li>► pre-purge. the burner remains in pre-purge.</li> <li>► after ignition, burner remains in operation.</li> </ul> When anomalies disappear the burner re-starts
<b>Orange 0.2s ON / Green 0.2s ON</b> Control box internal error	
<b>Green 0.2s ON / Red 0.2s ON</b> Reset pushbutton or remote reset failure	Remote reset / pushbutton is activated for more than 60 seconds. When anomaly appears the burner does not stop

Table 12

### 8.5.3 Fault finding

Line	Check	Action		
1	Control box is supplied with heat demand?	Yes	Go to line 2	
		No	Check boiler and system controls	
2	Is the pre-heater fitted or if no pre-heater is fitted, is the link fitted?	Yes	Go to line 3	
		No	Fit the Pre-Heater or link	
3	Motor starts after initialization check time 3.5 seconds?	Yes	Go to line 4	
		No	Go to line 3a	
	3a	Green 0.5 seconds ON/Red 0.5 seconds ON before lockout?	Yes	Go to line 5a
			No	Go to line 3b
	3b	Fan motor or oil pump seized?	Yes	Replace seized component
			No	Go to line 3c
	3c	230 Volts to motor across blue and black motor wires?	Yes	Go to line 3d
			No	Replace control box
3d	Approximately 35 Ω across blue and black motor wires?	Yes	Replace motor capacitor	
		No	Replace fan motor and check control box	
4	Motor runs for less than 12 seconds?	Yes	Go to line 4a	
		No	Go to line 5	
	4a	Motor gives 50 Volts a.c. across black and white wires?	Yes	Replace control box
			No	Replace fan motor

Table 13

Line	Check	Yes	Action	
5	Burner does not fire, burner locks out after 25 seconds from motor start?	Yes	Go to line 5a	
		No	Go to line 6	
	5a	Burner fires when the photo cell is covered?	Yes	Remove extraneous light
			No	Go to line 5b
	5b	Photo cell voltage $\geq 3.8V$ in the dark and approximately 1.2V in the light?	Yes	Replace the control board
No			Replace the photo cell	
6	Pump washing pressure 1 to 2 bar?	Yes	Go to line 7	
		No	Go to line 6a	
	6a	Pump pressure more than 6 bar?	Yes	Replace oil pump
			No	Go to line 6b
	6b	Check oil supply to the pump, if oil supply is OK	Go to line 6c	
	6c	Drive coupling broken?	Yes	Replace drive coupling
No			Replace oil pump	
7	Ignition spark present?	Yes	Go to line 8	
		No	Go to line 7a	
	7a	Are ignition leads and electrodes OK and set correctly?	Yes	Replace control box
			No	Replace/reset electrodes/ignition leads
8	Solenoid coil releases working pressure?	Yes	Go to line 9	
		No	Go to line 8a	
	8a	Does burner light or green 0.5 seconds ON/red 0.5 seconds ON before lockout?	Yes	Go to line 5a
			No	Go to line 8b
	8b	Contaminated fuel filters?	Yes	Clean/Replace filters
			No	Go to line 8c
	8c	Coil lead OK	Yes	Go to line 8d
			No	Replace solenoid coil lead
	8d	Solenoid coil resistance 90 to 110 $\Omega$	Yes	Go to line 8e
			No	Replace solenoid coil
8e	After 15 seconds from motor start, 25 to 30 Volts d.c. to solenoid coil? (coil connected)	Yes	Replace oil pump	
		No	Replace control box	
9	Air set correctly?	Yes	Go to line 10	
		No	Adjust combustion air settings	
10	Does the burner light? Flue damper fitted? (if required)	Yes	Go to line 11	
		No	Go to line 10a	
	10a	Is the nozzle atomising the fuel?	Yes	Go to line 11
			No	Go to line 10b
	10b	Nozzle new?	Yes	Go to line 10c
			No	Replace nozzle
10c	Check oil pipe from pump to nozzle holder	Clean/ replace pump and fuel line filters		
11	Combustion head set correctly?	Yes	Go to line 11a	
		No	Reset combustion head	
	11a	Flame goes out then re-lights	Yes	Go to line 11c
			No	Go to line 11b
	11b	Boiler or flue blocked	Yes	Clear blockage
			No	Go to line 11c
	11c	If balanced flue, remove the snorkel and test - now OK?	Yes	Go to line 11d
			No	Go to line 11e
	11d	Balanced flues can recirculate gases causing recycling	Check the flue position and seals	
11e	Photo cell voltage $\geq 3.8V$ in the dark and approximately 1.2V in the light?	Yes	Replace the control box	
		No	Replace photocell	

Table 13

### 8.5.4 Flame sensing photocell 12/18 models

To check the correct functioning of the photocell, perform the following actions:

- ▶ Electrically isolate the burner
- ▶ Remove the photocell
- ▶ Connect a voltmeter across the blue and brown wires to the photocell
- ▶ Reconnect the power to the burner and wait until the burner locks out due to the false flame fault (red and green LEDs blinking)
- ▶ Cover the photocell to exclude any light and the voltmeter should read 3.8 Volts or higher
- ▶ Expose the photocell to light and the voltmeter should read approximately 1.2Volts
- ▶ If these two conditions are not met, change the photocell
- ▶ Disconnect the voltmeter
- ▶ Disconnect the burner and replace the photocell

### 8.5.5 Flame sensing photocell 18/25 and 25/32 models

If the photocell is suspected to be faulty, replace the photocell.

### 8.6 Oil supply vacuum testing

A vacuum gauge can be attached to the oil pump vacuum test port [1] and the boiler operated to check the vacuum readings. Oil pumps can operate if readings are between plus 0.4 bar and minus 0.35 bar.

This means oil tanks can be 4 metres higher (to top of oil) or 3.5 metres lower (if fitted with a de-aerator or two-pipe oil delivery system) than the oil pump.

If vacuum is greater than minus 0.35 bar then you must also check that the oil supply is not obstructed and that the oil supply pipe is correctly sized.

Accessory 8-716-116-333-0 is available to assist in connecting a vacuum gauge to the vacuum test port.

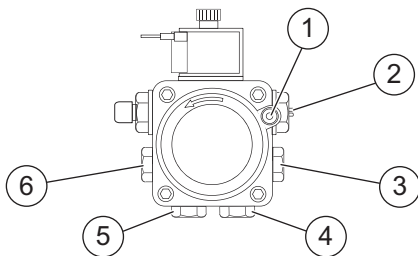

6720809437-33.2Wo

Fig. 92 Oil pump ports/connections

- [1] Vacuum gauge port
- [2] Pressure adjuster
- [3] Bleed and pressure gauge port
- [4] Return connection
- [5] Inlet connection
- [6] Auxiliary pressure gauge port

### 8.7 Air pressure switch and flue overheat reset

This is a blocking error that must be reset by pressing thermostat reset button or air pressure switch reset button.

If the flue-gas temperature exceeds the cut-off point or the flue is restricted, the appliance will lockout indicated by code E9 210 [1]

- ▶ Press the flue-gas thermostat reset button [3], located on the underside of the support bracket [2].

-or-

- ▶ Press the air pressure reset button [4], located on the underside of the support bracket [2].

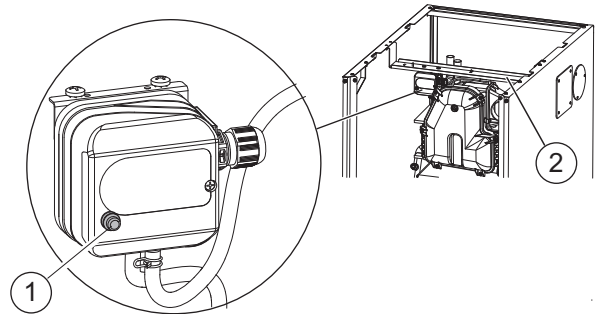

6720821686-09.1Wo

Fig. 93

- [1] Air pressure switch reset
- [2] Boiler cross brace

### 8.8 Air pressure switch connections

**NOTICE:** APS pressure sensing tubes

- ▶ Ensure that the pressure sensing tubes are not kinked or trapped when working on the boiler.
- ▶ Kinked or trapped tubes will prevent the APS from functioning correctly

#### **i** Air pressure switch sensing tube connections:

- ▶ Ensure that the sensing tubes are connected correctly, refer to figure 94

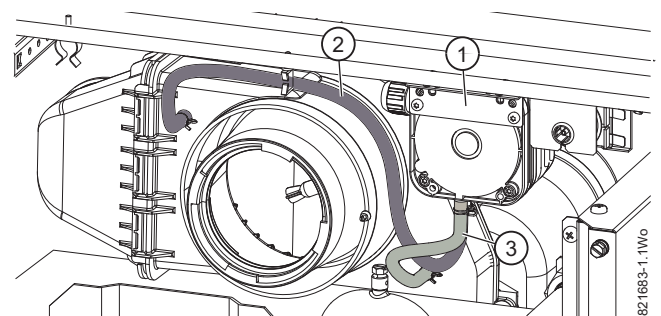

821683-1.1Wo

Fig. 94 Sensing tube connections

- [1] Air pressure switch
- [2] Air intake connection (front connection)
- [3] Flue exhaust connection (rear connection marked with a +)

### 8.9 Oil appliance commissioning checklist

This Commissioning checklist is to be completed in full by the competent person who commissioned the appliance as a means of demonstrating compliance with the appropriate Building Regulations and then handed to the customer to keep for future reference.



**IMPORTANT**

▶ Leave this manual with the Homeowner.

**Appliance details**

Appliance make and model: \_\_\_\_\_  
 Appliance serial number: \_\_\_\_\_

**Commissioning Engineer**

Company name: \_\_\_\_\_  
 Company address: \_\_\_\_\_  
 Telephone number: \_\_\_\_\_  
 Commissioned by (signature) \_\_\_\_\_  
 (print name) \_\_\_\_\_  
 Commissioning date: \_\_\_\_\_

**Commissioning checks**

Oil type used is Kerosene	Yes <input type="checkbox"/>
Pump pressure	PSI
CO <sub>2</sub>	%
CO	ppm
CO/CO <sub>2</sub> ratio	
Smoke reading	
Flue gas temperature	°C
Flue pressure	
Burner model:	

**Controls: Tick the appropriate boxes**

Time and temperature control to heating	Room thermostat and programmer/timer	<input type="checkbox"/>	Programmable room thermostat	<input type="checkbox"/>
	Load/Weather compensation	<input type="checkbox"/>	Optimum start control	<input type="checkbox"/>
Time and temperature control hot water	Cylinder thermostat and programmer/timer	<input type="checkbox"/>	Combination boiler	<input type="checkbox"/>
Heating zone valves	Fitted	<input type="checkbox"/>	Not required	<input type="checkbox"/>
Hot water zone valves	Fitted	<input type="checkbox"/>	Not required	<input type="checkbox"/>
Thermostatic radiator valves	Fitted	<input type="checkbox"/>	Not required	<input type="checkbox"/>
Automatic by-pass valve fitted to system	Fitted	<input type="checkbox"/>	Not required	<input type="checkbox"/>
Boiler interlock			Provided	<input type="checkbox"/>

**All Systems**

The system has been flushed and cleaned in accordance with BS7593 and appliance manufacturer's instructions? Yes

What system cleaner was used? \_\_\_\_\_

What inhibitor was used? \_\_\_\_\_ Quantity  litres

Has a system filter been fitted? Yes  No

The condensate drain has been installed in accordance with the manufacturer's instructions and/or BS5546/BS6789? Yes

If the condensate pipe terminates externally has the pipe diameter been increased and weatherproof insulation fitted? Yes

**Central Heating mode: Measure and record**

Central Heating flow temperature  °C      Central Heating return temperature  °C

**Domestic Hot Water mode: Measure and record**

**Combination boilers only**

Is the installation in a hard water area (above 200ppm)? Yes  No

If yes, has a water scale reducer been fitted? Yes  No

What type of scale reducer has been fitted? \_\_\_\_\_

Cold Water Inlet temperature  °C      Hot Water Outlet temperature  °C

Water flow rate  l/min

**All installations**

Fire valve fitted rated to 85 °C. Yes

Is the flue damper correctly fitted? Yes  No

Are the hoses from the Air pressure switch correctly routed and free from kinking? Yes  No

Is a solid non-combustible surface large enough to accommodate the appliance provided? Yes  No

Is the oil tank and supply clean and free from contamination? Yes  No

Does the installation comply with current OFTEC Regulation? Yes  No

The heating and hot water system complies with the appropriate Building Regulations? Yes  No

The appliance and associated products have been installed and commissioned in accordance with the manufacturer's instructions? Yes  No

The operation of the appliance and system controls have been demonstrated to and understood by the customer? Yes  No

### 8.10 Service interval record

It is recommended that your appliance is serviced annually and that the Service Interval Record is completed and signed.  
 Before completing the service Interval record below, ensure that you have carried out the service functions described in this manual.  
 Always use the manufacturer's recommended spare parts

<b>Service 1</b>		Date:	
Engineer's name:			
Company name:			
Telephone number:			
Registration number:			
Fire valve inspected (rated to 85 °C)		Yes <input type="checkbox"/> No <input type="checkbox"/>	
Nozzle changed?	Yes <input type="checkbox"/> No <input type="checkbox"/>	Pump pressure:	psi
CO <sub>2</sub>	CO	ppm	CO/CO <sub>2</sub> ratio
F.G.T.	°C	Flue pressure:	
Comments:			
Signature:			

<b>Service 3</b>		Date:	
Engineer's name:			
Company name:			
Telephone number:			
Registration number:			
Fire valve inspected (rated to 85 °C)		Yes <input type="checkbox"/> No <input type="checkbox"/>	
Nozzle changed?	Yes <input type="checkbox"/> No <input type="checkbox"/>	Pump pressure:	psi
CO <sub>2</sub>	CO	ppm	CO/CO <sub>2</sub> ratio
F.G.T.	°C	Flue pressure:	
Comments:			
Signature:			

<b>Service 5</b>		Date:	
Engineer's name:			
Company name:			
Telephone number:			
Registration number:			
Fire valve inspected (rated to 85 °C)		Yes <input type="checkbox"/> No <input type="checkbox"/>	
Nozzle changed?	Yes <input type="checkbox"/> No <input type="checkbox"/>	Pump pressure:	psi
CO <sub>2</sub>	CO	ppm	CO/CO <sub>2</sub> ratio
F.G.T.	°C	Flue pressure:	
Comments:			
Signature:			

<b>Service 7</b>		Date:	
Engineer's name:			
Company name:			
Telephone number:			
Registration number:			
Fire valve inspected (rated to 85 °C)		Yes <input type="checkbox"/> No <input type="checkbox"/>	
Nozzle changed?	Yes <input type="checkbox"/> No <input type="checkbox"/>	Pump pressure:	psi
CO <sub>2</sub>	CO	ppm	CO/CO <sub>2</sub> ratio
F.G.T.	°C	Flue pressure:	
Comments:			
Signature:			

<b>Service 9</b>		Date:	
Engineer's name:			
Company name:			
Telephone number:			
Registration number:			
Fire valve inspected (rated to 85 °C)		Yes <input type="checkbox"/> No <input type="checkbox"/>	
Nozzle changed?	Yes <input type="checkbox"/> No <input type="checkbox"/>	Pump pressure:	psi
CO <sub>2</sub>	CO	ppm	CO/CO <sub>2</sub> ratio
F.G.T.	°C	Flue pressure:	
Comments:			
Signature:			

<b>Service 2</b>		Date:	
Engineer's name:			
Company name:			
Telephone number:			
Registration number:			
Fire valve inspected (rated to 85 °C)		Yes <input type="checkbox"/> No <input type="checkbox"/>	
Nozzle changed?	Yes <input type="checkbox"/> No <input type="checkbox"/>	Pump pressure:	psi
CO <sub>2</sub>	CO	ppm	CO/CO <sub>2</sub> ratio
F.G.T.	°C	Flue pressure:	
Comments:			
Signature:			

<b>Service 4</b>		Date:	
Engineer's name:			
Company name:			
Telephone number:			
Registration number:			
Fire valve inspected (rated to 85 °C)		Yes <input type="checkbox"/> No <input type="checkbox"/>	
Nozzle changed?	Yes <input type="checkbox"/> No <input type="checkbox"/>	Pump pressure:	psi
CO <sub>2</sub>	CO	ppm	CO/CO <sub>2</sub> ratio
F.G.T.	°C	Flue pressure:	
Comments:			
Signature:			

<b>Service 6</b>		Date:	
Engineer's name:			
Company name:			
Telephone number:			
Registration number:			
Fire valve inspected (rated to 85 °C)		Yes <input type="checkbox"/> No <input type="checkbox"/>	
Nozzle changed?	Yes <input type="checkbox"/> No <input type="checkbox"/>	Pump pressure:	psi
CO <sub>2</sub>	CO	ppm	CO/CO <sub>2</sub> ratio
F.G.T.	°C	Flue pressure:	
Comments:			
Signature:			

<b>Service 8</b>		Date:	
Engineer's name:			
Company name:			
Telephone number:			
Registration number:			
Fire valve inspected (rated to 85 °C)		Yes <input type="checkbox"/> No <input type="checkbox"/>	
Nozzle changed?	Yes <input type="checkbox"/> No <input type="checkbox"/>	Pump pressure:	psi
CO <sub>2</sub>	CO	ppm	CO/CO <sub>2</sub> ratio
F.G.T.	°C	Flue pressure:	
Comments:			
Signature:			

<b>Service 10</b>		Date:	
Engineer's name:			
Company name:			
Telephone number:			
Registration number:			
Fire valve inspected (rated to 85 °C)		Yes <input type="checkbox"/> No <input type="checkbox"/>	
Nozzle changed?	Yes <input type="checkbox"/> No <input type="checkbox"/>	Pump pressure:	psi
CO <sub>2</sub>	CO	ppm	CO/CO <sub>2</sub> ratio
F.G.T.	°C	Flue pressure:	
Comments:			
Signature:			

## Notes



**If in the unlikely event the boiler does not give complete satisfaction, before calling for a service engineer, the installer should check the following:**

**General checks:**

1. Is there 230V across the boiler live and neutral terminals?
2. Is the polarity correct? (230V across live and earth, 0V across neutral and earth)?
3. Is the air bled from the primary system?
4. Is the air bled from the oil supply?
5. Is the flue sized and routed correctly?

**Boiler runs straight to lockout**

1. Has the oil line been purged of air?
2. Where an air eliminator is used in conjunction with a top feed oil tank the non-return valve, (if fitted), should be removed from the oil dip pipe.

**Boiler locks out at the start of a demand (Heating off overnight for example)**

1. If an air eliminator is being used, check that there are no leaks that allow air to be pulled into the oil supply.
2. If a two pipe oil supply is being used, has a non-return valve been fitted to the inlet pipe? Refer to the instructions for guidelines.

**No domestic hot water**

1. Is there a domestic hot water demand from the programmer and has the tank reached temperature?
2. Is the circulating pump operating?
3. Are the programmer, tank thermostat, circulating pump and diverter valve/zone valves wired correctly?
4. Is there 230V across L and N? If not there is no demand to the boiler from the controls or the controls wiring is not correct.

**No central heating**

1. Are both programmer and room thermostat on demand for central heating?
2. Are the room thermostat, programmer, circulating pump and diverter valve/zone valves (if CH and DHW system) wired correctly?
3. Is the circulating pump operating?
4. Is there 230V across L and N? If not there is no demand to the boiler from the controls or the controls wiring is not correct.



**NOTICE: APPLIANCE OPERATION**  
UNDER NO CIRCUMSTANCES MUST AN  
APPLIANCE BE LEFT TO OPERATE WITH ANY  
CONTROL LINKED OUT OR OVER RIDDEN.

**WORCESTER, BOSCH GROUP:**

TECHNICAL SUPPORT:	0330 123 3366
APPOINTMENTS:	0330 123 9339
SPARES:	0330 123 9779
LITERATURE:	0330 123 9119
TRAINING:	0330 123 0166
SALES:	0330 123 9669

Worcester, Bosch Group  
Cotswold Way, Warndon, Worcester WR4 9SW.  
Tel. 0330 123 9559

Worcester, Bosch Group is a brand name of Bosch Thermotechnology Ltd.  
worcester-bosch.co.uk

6 721 846 263 (2022/01)

**WORCESTER**  
Bosch Group