

# Draft Installation and Servicing Instructions

# R 22-1 HE system



Wall mounted condensing boiler for central heating



6 720 610 577-00.10

**ZB 22-1 R 26**

*benchmark*

6 720 611 677 GB (03.11)

**WORCESTER**  
Bosch Group

# Contents

---

**Safety precautions 3**

---

**Symbols 3**

---

**1 Details of the appliance 4**

1.1	EC Declaration of Conformity	4
1.2	Standard package	4
1.3	Description of appliance	4
1.4	Accessories	5
1.5	Casing dimensions	5
1.6	Layout of appliance	6
1.7	Function (with optional extra motorised valve)	7
1.8	Electrical wiring diagram	8
1.9	Technical data	9

---

**2 Installation regulations 10**

---

**3 Installation 11**

3.1	Important remarks	11
3.2	Sealed systems	11
3.3	Siting the appliance	13
3.4	Pre-piping the system	14
3.5	Fitting the appliance	14
3.6	Checking the connections	16
3.7	Flue Systems	16
3.7.1	Siting the Flue Terminal	17
3.7.2	Installation of the flue	18
3.7.3	Flue duct preparation and assembly	20

---

**4 Electrical connections 21**

4.1	Connecting the appliance	21
4.2	Mains Voltage external controls connections	22
4.3	Wiring to your system	22
4.3.1	Pre-wired Remote S Plan	22

---

**5 Commissioning 23**

5.1	Commissioning	23
5.2	Switching the appliance on/off	24
5.3	Switching on the central heating	24
5.4	System controls	24
5.5	Appliances with optional plug-in diverter valve: Setting hot water temperature	25
5.6	Summer mode (hot water only)	25
5.7	Frost protection	25
5.8	Pump anti-seize function	25
5.9	Fault Condition	26

---

**6 Individual settings 27**

6.1	Mechanical settings	27
6.1.1	Checking the size of the expansion vessel	27
6.1.2	Setting the central heating flow temperature	27
6.1.3	Changing the heating pump characteristic	27
6.2	Settings on the Bosch Heatronic	28

6.2.1	Operating the Bosch Heatronic	28
6.2.2	Selecting the pump control mode for central heating mode (Service Function 2.2)	28
6.2.3	Setting the anti-cycle time (Service Function 2.4)	28
6.2.4	Setting the maximum CH flow temperature (Service Function 2.5)	29
6.2.5	Setting the switching difference (Service Function 2.6)	29
6.2.6	Setting the heating output (Service Function 5.0)	29
6.3	Setting the gas/air ratio	29

---

**7 Converting the appliance to different gas types 30**

7.1	Setting the gas/air ratio	30
7.2	Testing combustion air/flue gas at set heat output	32
7.2.1	Testing the O <sub>2</sub> or CO <sub>2</sub> level in the combustion air	32
7.2.2	Testing CO and CO <sub>2</sub>	32

---

**8 Maintenance 33**

8.1	Pre-Service Check List	34
8.2	Description of servicing operations	35
8.3	Replacement of Parts	38
8.3.1	PCB control board and transformer	38
8.3.2	Pump	39
8.3.3	Optional 3-way diverter valve	40
8.3.4	3-way diverter valve motor	40
8.3.5	Sensors	40
8.3.6	Gas Valve	41
8.3.7	Electrode assembly	41
8.3.8	Pressure gauge	41
8.3.9	Expansion vessel	41
8.3.10	Pressure Relief Valve	41
8.3.11	Burner	41
8.3.12	Primary Heat Exchanger	41

---

**9 Appendix 43**

9.1	Fault Codes	43
9.2	Short parts list	44
9.3	Heating/hot water output settings (N.G)	45
9.4	Heating/hot water output settings (L.P.G)	45
9.5	Operational Flow diagrams	46
9.5.1	Central heating function	46

## Safety precautions

### If you smell gas

- ▶ Turn off gas service cock at the meter.
- ▶ Open windows and doors.
- ▶ Do not operate any electrical switches.
- ▶ Extinguish any naked flames.
- ▶ Telephone your gas company.

### If you smell fumes from the appliance

- ▶ Switch off appliance (see page 24).
- ▶ Open windows and doors.

### Fitting and modifications

- ▶ Fitting of the appliance or any controls to the appliance may only be carried out by a competent engineer in accordance with the Gas Safety (Installation and Use) Regulations 1998.
- ▶ Flue systems must not be modified in any ways other than as described in the fitting instructions.
- ▶ This appliance is for use on sealed primary systems only.

### Maintenance

- ▶ **The user is recommended:** to have the system regularly serviced in order to ensure that it functions reliably and safely.
- ▶ Use only original spare parts!

### Combustible materials

- ▶ Do not store or use any combustible materials (paper, thinners, paints etc.) in the vicinity of the appliance.

### Health and safety

- ▶ This appliance contains no asbestos products.
- ▶ There is no potential hazard due to the appliance being electrically unsafe.
- ▶ There are no substances used in the construction that are a potential hazard in relation to the COSHH Regulations (Control of Substances Hazardous to Health Regulations 1988).

### Combustion air/Ambient atmosphere

- ▶ The combustion air/ambient atmosphere should be kept free of chemically aggressive substances (e.g. halogenated hydrocarbons which contain chlorine or fluorine compounds). This will prevent corrosion.

### Instructions to the customer

- ▶ Explain to the customer how the appliance works and how to operate it.
- ▶ Advise the user that he/she must not make any modifications to the appliance or carry out any repairs on it.
- ▶ These instructions are to be left with the user or at the Gas meter.
- ▶ Important: These instructions apply in the UK only.

## Symbols



**Safety instructions** in this document are identified by a warning-triangle symbol and are printed on a grey background.



**Notes** containing important information are identified by the symbol shown on the left. They are bordered by horizontal lines above and below the text.

## 1 Details of the appliance

### 1.1 EC Declaration of Conformity

This appliance is in accordance with the applicable requirements of the Gas Appliance Directive, Boiler Efficiency Directive, Electromagnetic Compatibility Directive and the Low Voltage Directive.

<b>PIN</b>	<b>CE-0085 BL XXXX</b>
<b>Category UK</b>	<b>II<sub>2H</sub> 3P</b>
<b>Appliance Type</b>	<b>C<sub>13</sub>, C<sub>33</sub></b>

Table 1

### 1.2 Standard package

- Gas condensing boiler for central heating
- Fixings (screws etc.)
- Condensate drain pipe.

### 1.3 Description of appliance

- Wall-mounted appliance, siting not dependent on room size
- Natural gas models are low-emission appliances
- Multi function display
- Bosch Heatronic control system
- Automatic ignition
- Modulating control
- Full safety systems incorporating Bosch Heatronic with flame ionisation monitoring, solenoid valves and temperature sensors
- Concentric flue/air duct with testing point for CO<sub>2</sub>/CO
- Regulated speed fan
- Pre-mix burner
- Temperature control for central heating
- Safety temperature limiter in 24 V electrical circuit
- Three-speed central heating pump with automatic vent
- Relief valve, pressure gauge, expansion vessel
- Flue gas temperature limiter (120 °C)
- Condensate Trap
- Connecting possibility for S-Plan System.

## 1.4 Accessories

- Standard horizontal flue kit at 100 mm outside diameter for flues up to 4 m in length.
- Flue duct kits for horizontal (125 mm outside diameter) for flue lengths up to 13 m and vertical flue systems for flue lengths up to 13.7 m. Fitting instructions are sent with these kits.
- Heating programmers
- Security kit
- Single or Twin channel digital timer
- Single channel mechanical timer
- RF controlled Digistat

- Night Set Back module
- TR2 room controllers
- Motorised valve is available as an optional extra. If this option is used then the DT2, TR2 Optimising Room Thermostat and the Night Set Back Module will be required.

## 1.5 Casing dimensions

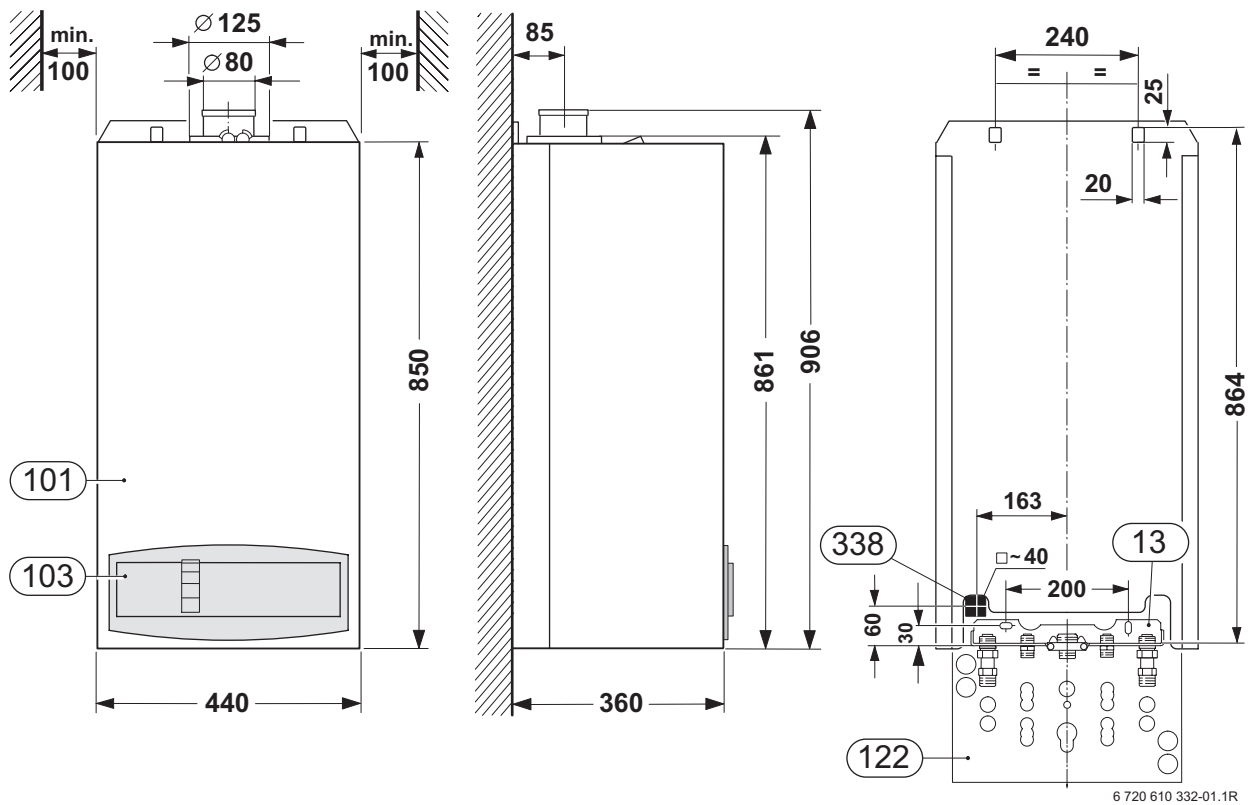
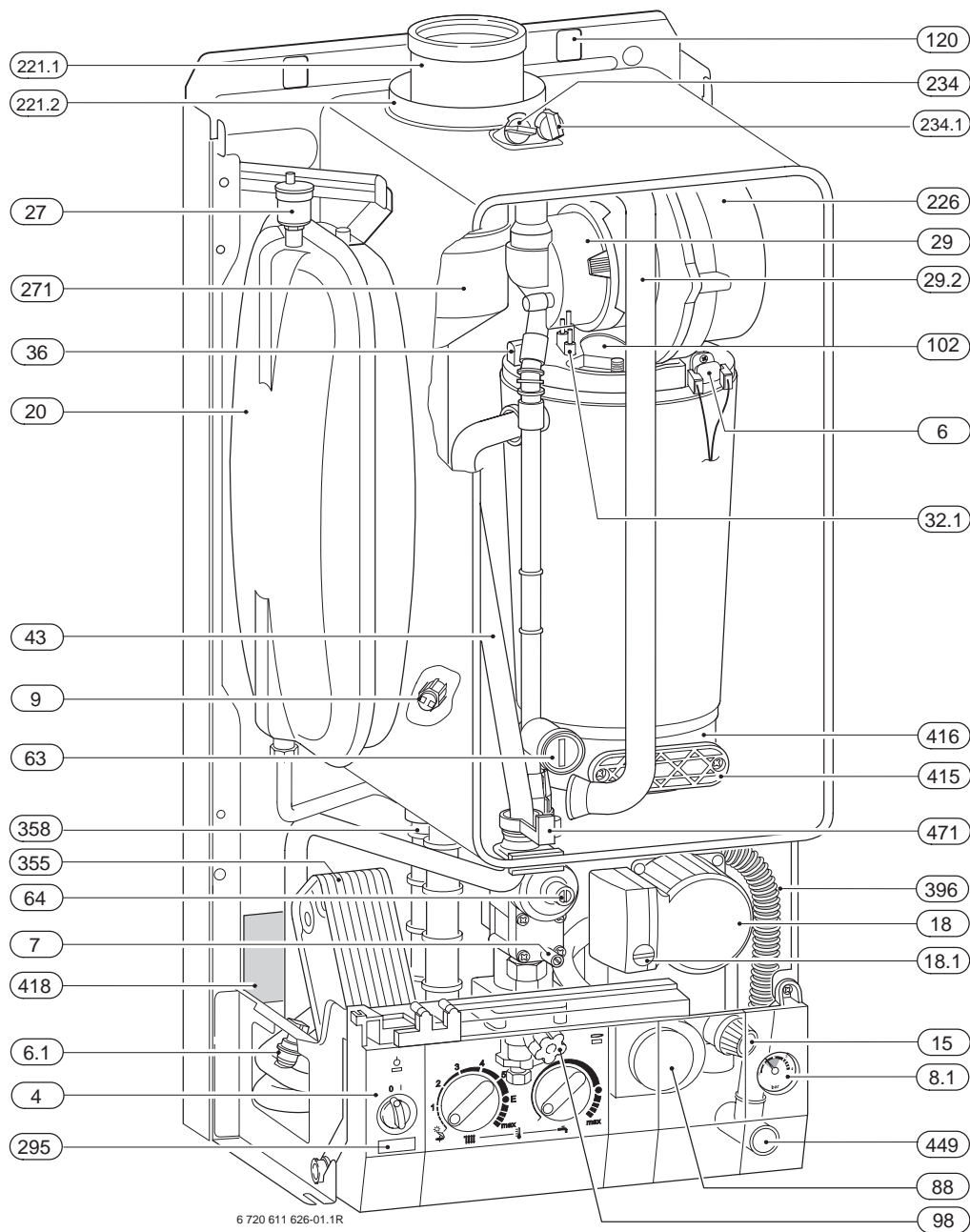

Fig. 1

- |            |                               |
|------------|-------------------------------|
| <b>13</b>  | Manifold assembly (accessory) |
| <b>101</b> | Outer case                    |
| <b>103</b> | Facia cover                   |
| <b>122</b> | no                            |
| <b>338</b> | no                            |

## 1.6 Layout of appliance



6 720 611 626-01.1R

Fig. 2

- |             |   |              |   |
|-------------|---|--------------|---|
| <b>4</b>    | Heatronic control                         | <b>88</b>    | 3-way valve (combi) (not included)                          |
| <b>6</b>    | Heat exchanger safety temperature limiter | <b>98</b>    | DHW flow switch (combi) (not included)                      |
| <b>6.1</b>  | Hot water NTC sensor (not included)       | <b>102</b>   | Inspection window   |
| <b>7</b>    | Testing point for gas supply pressure     | <b>120</b>   | Fixing points   |
| <b>8.1</b>  | Pressure gauge                            | <b>221.1</b> | Flue duct   |
| <b>9</b>    | Flue gas temperature limiter              | <b>221.2</b> | Combustion air intake                                       |
| <b>15</b>   | Relief valve                              | <b>226</b>   | Fan assembly  |
| <b>18</b>   | Pump                                      | <b>295</b>   | Appliance type sticker                                      |
| <b>18.1</b> | Pump speed selector switch                | <b>271</b>   | Flue duct   |
| <b>20</b>   | Expansion vessel                          | <b>355</b>   | Plate-type domestic hot water heat exchanger (not included) |
| <b>27</b>   | Automatic air vent                        | <b>358</b>   | Condensate trap   |
| <b>29</b>   | Air gas Mixer unit                        | <b>415</b>   | Cover plate for cleaning access                             |
| <b>29.2</b> | Air intake pipe                           | <b>416</b>   | Condensate collector  |
| <b>32.1</b> | Electrode assembly                        | <b>417</b>   | Clip for fixing outer case                                  |
| <b>36</b>   | Temperature sensor in CH flow             | <b>418</b>   | Data plate  |
| <b>43</b>   | CH flow                                   | <b>423</b>   | Siphon  |
| <b>63</b>   | Adjustable gas flow restrictor            | <b>471</b>   | Locating tab for fan  |
| <b>64</b>   | Adjusting screw for min. gas flow volume  |              |   |

### 1.7 Function (with optional extra motorised valve)

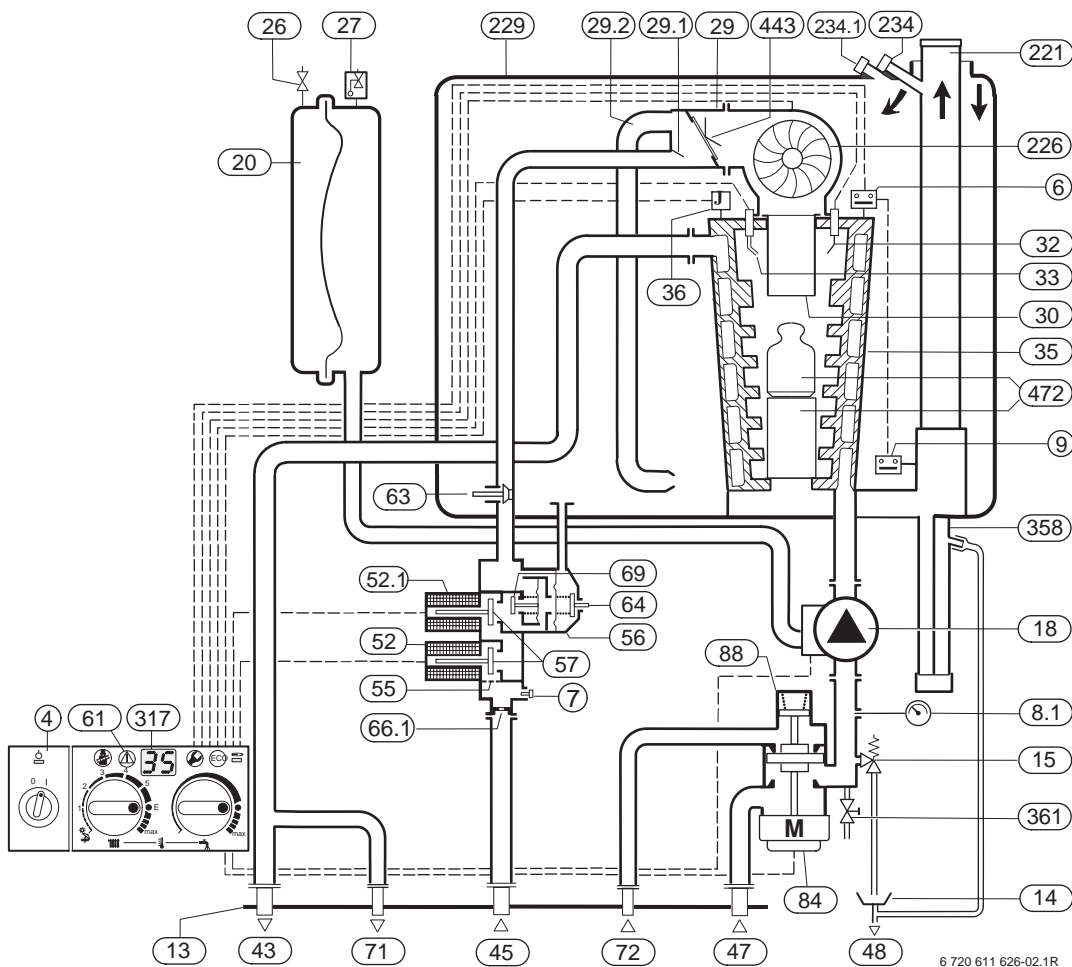
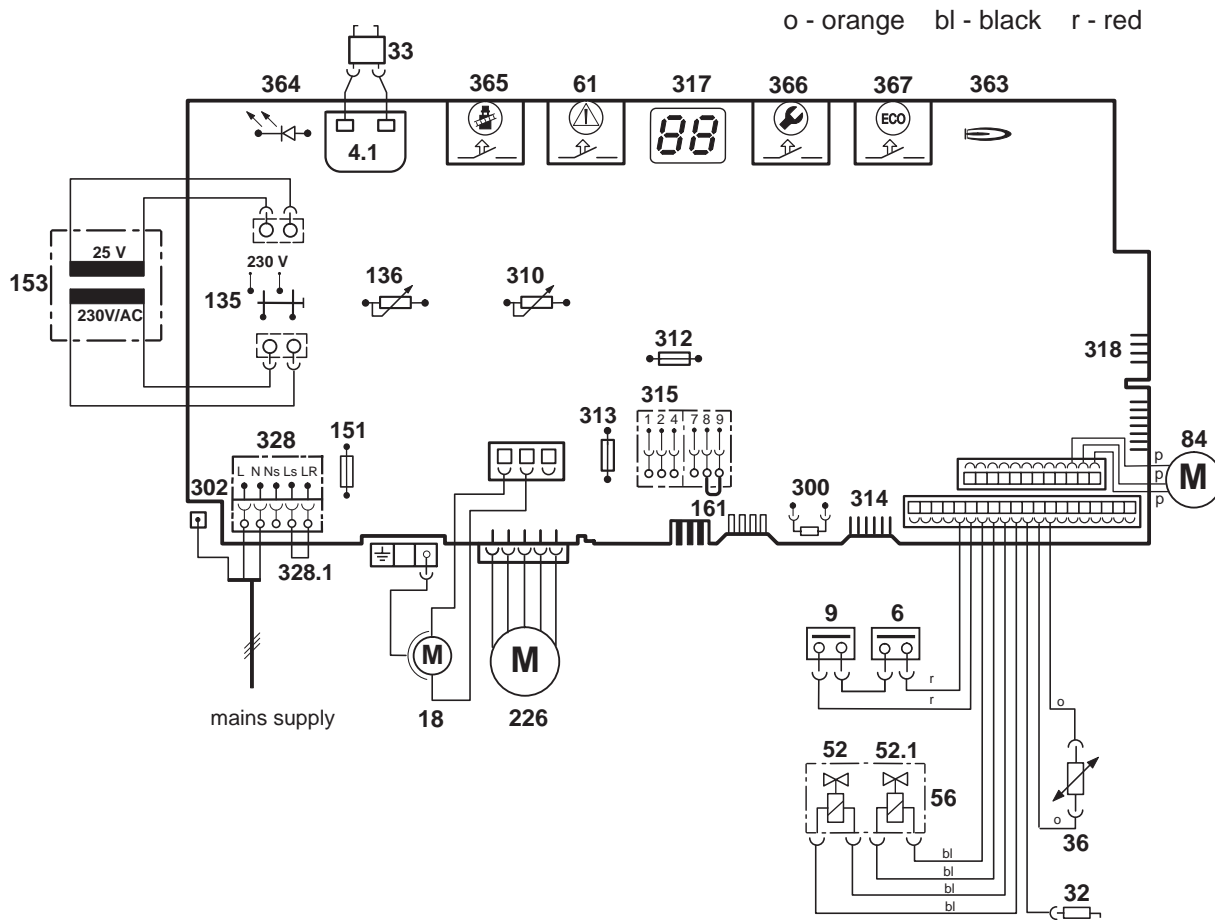

Fig. 3

- |             |  |              |   |
|-------------|--|--------------|---|
| <b>4</b>    | Bosch Heatic control                                   | <b>69</b>    | Control valve   |
| <b>6</b>    | Temperature limiter, heat exchanger                    | <b>71</b>    | Storage water heater outflow (only with optional motorised valve) |
| <b>7</b>    | Testing point for gas supply pressure                  | <b>72</b>    | Storage water heater return (only with optional motorised valve)  |
| <b>8.1</b>  | Pressure gauge   | <b>84</b>    | Motor (optional extra)  |
| <b>9</b>    | Flue gas temperature limiter                           | <b>88</b>    | 3-way valve (optional extra)                                      |
| <b>13</b>   | Manifold   | <b>221</b>   | Flue duct   |
| <b>15</b>   | Safety valve   | <b>226</b>   | Fan   |
| <b>18</b>   | Central heating pump                                   | <b>229</b>   | Inner casing  |
| <b>20</b>   | Expansion vessel                                       | <b>234</b>   | Testing point for flue gas  |
| <b>26</b>   | Charging Valve   | <b>234.1</b> | Testing point for combustion air                                  |
| <b>27</b>   | Automatic vent   | <b>317</b>   | Display   |
| <b>29</b>   | Mixer unit   | <b>355</b>   | Plate-type heat exchanger   |
| <b>29.1</b> | Bi-metallic thermostat for combustion air compensation | <b>358</b>   | Condensate trap   |
| <b>29.2</b> | Air intake pipe  | <b>422</b>   | Digital timer   |
| <b>30</b>   | Burner   | <b>423</b>   | Siphon  |
| <b>32</b>   | Flame sensing electrode                                | <b>443</b>   | Diaphragm   |
| <b>33</b>   | Igniter electrode                                      | <b>472</b>   | Displacement cylinder   |
| <b>35</b>   | Heat exchanger with cooled combustion chamber          |              |   |
| <b>36</b>   | Temperature sensor in CH flow                          |              |   |
| <b>43</b>   | CH flow  |              |   |
| <b>45</b>   | Gas inlet  |              |   |
| <b>47</b>   | CH return  |              |   |
| <b>52</b>   | Solenoid valve 1                                       |              |   |
| <b>52.1</b> | Solenoid valve 2                                       |              |   |
| <b>55</b>   | Filter   |              |   |
| <b>56</b>   | Gas valve CE 427                                       |              |   |
| <b>57</b>   | Main valve disc  |              |   |
| <b>61</b>   | Reset button   |              |   |
| <b>63</b>   | Adjustable gas flow restrictor                         |              |   |
| <b>64</b>   | Adjusting screw for min. gas inlet flow volume         |              |   |

### 1.8 Electrical wiring diagram



6 720 610 601-02.20

Fig. 4

- |              |  |            |                                 |
|--------------|--|------------|---------------------------------|
| <b>4.1</b>   | Ignition transformer                     | <b>364</b> | Indicator lamp for power supply |
| <b>6</b>     | Temperature limiter, heat exchanger      | <b>365</b> | “Chimney sweep” button          |
| <b>9</b>     | Flue gas temperature limiter             | <b>366</b> | Service button                  |
| <b>18</b>    | Pump                                     | <b>367</b> | ECO button                      |
| <b>32</b>    | Flame sensing electrode                  |            |                                 |
| <b>33</b>    | Ignition electrode                       |            |                                 |
| <b>36</b>    | Temperature sensor in CH flow            |            |                                 |
| <b>52</b>    | Solenoid valve 1                         |            |                                 |
| <b>52.1</b>  | Solenoid valve 2                         |            |                                 |
| <b>56</b>    | Gas valve CE 427                         |            |                                 |
| <b>61</b>    | Reset button                             |            |                                 |
| <b>84</b>    | Motor, 3-way valve (optional extra)      |            |                                 |
| <b>135</b>   | Master switch                            |            |                                 |
| <b>136</b>   | Temperature control for CH flow          |            |                                 |
| <b>151</b>   | Fuse, slow 2.5 A, AC 230 V               |            |                                 |
| <b>153</b>   | Transformer                              |            |                                 |
| <b>161</b>   | Link                                     |            |                                 |
| <b>226</b>   | Fan                                      |            |                                 |
| <b>300</b>   | Code plug                                |            |                                 |
| <b>302</b>   | Earth connection                         |            |                                 |
| <b>310</b>   | Temperature control for hot water        |            |                                 |
| <b>312</b>   | Fuse, slow T 1,6 A                       |            |                                 |
| <b>313</b>   | Fuse, slow T 0,5 A                       |            |                                 |
| <b>314</b>   | Connector for programmer                 |            |                                 |
| <b>315</b>   | Terminal block for programmer            |            |                                 |
| <b>317</b>   | Digital display                          |            |                                 |
| <b>328</b>   | Terminal block for AC 230 V Mains supply |            |                                 |
| <b>328.1</b> | Link                                     |            |                                 |
| <b>363</b>   | Indicator lamp for burner                |            |                                 |

## 1.9 Technical data

	Units	22-1 HE Natural gas	22-1 HE Propane		
Max. rated heat output net 40/30°C central heating	kW	21.7	21.7		
Max. rated heat output net 50/30°C central heating	kW	21.5	21.5		
Max. rated heat output net 80/60°C central heating	kW	20.6	20.6		
Max. rated heat input net	kW	20.8	20.8		
Min. rated heat output net 40/30°C	kW	8.2	10.3		
Min. rated heat output net 50/30°C	kW	8.1	10.2		
Min. rated heat output net 80/60°C	kW	7.3	9.2		
Min. rated heat input net	kW	7.5	9.4		
Max. rated heat output net, domestic hot water	kW	25.7	25.7		
Max. rated heat input net, domestic hot water	kW	26.0	26.0		
<b>Maximum gas flow rate – After 10 minutes from lighting</b>					
Natural gas G20 (CVnet 34.02 MJ/m <sup>3</sup> )	m <sup>3</sup> /h	2.7			
LPG (CVnet 88 MJ/m <sup>3</sup> )	kg/h				
<b>Gas supply pressure</b>					
Natural gas G20 (CVnet 34.02 MJ/m <sup>3</sup> )	mbar	20	-		
LPG (CVnet 88 MJ/m <sup>3</sup> )	mbar		37		
<b>Expansion vessel</b>					
Charge pressure	bar	0.75	0.75		
Total capacity	l	10	10		
<b>Flue</b>					
Flue gas temp. 80/60°C, rated/min. load	°C	96/60	96/60		
Flue gas temp. 40/30°C, rated/min. load	°C	72/32	72/32		
Residual delivery pressure (inc. pressure drop in air intake duct)	Pa	80	80		
CO <sub>2</sub> level at max. rated heat output	%	8.8	10.5		
CO <sub>2</sub> level at min. rated heat output	%	8.5	10.2		
NO <sub>x</sub> -class		5	5		
SEDBUK figure	Band	A	A		
<b>Condensate</b>					
Max. condensation rate (t <sub>R</sub> = 30°C)	l/h	2.2	2.2		
pH-value, approx.		4.8	4.8		
<b>General Data</b>					
Electrical power supply voltage	AC ... V	230	230		
Frequency	Hz	50	50		
Max. power consumption	W	105	105		
Noise output level	dB(A)	35	35		
Appliance protection rating	IP	X4D	X4D		
Max. CH flow temperature	°C	nom. 90	nom. 90		
Max. permissible operating pressure (CH)	bar	2.5	2.5		
Permissible ambient temperatures	°C	0 - 50	0 - 50		
Nominal capacity of appliance	l	2.5	2.5		
Weight (excluding packaging)	kg	38	38		

Table 2

**Condensate analysis, mg/l**

Ammonium 1.2	Nickel 0.15
Lead ≤ 0.01	Mercury ≤ 0.0001
Cadmium ≤ 0.001	Sulphate 1
Chromium ≤ 0.1	Zinc ≤ 0.015
Halogenated hydrocarbons ≤ 0.002	Tin ≤ 0.01
Hydrocarbons 0.015	Vanadium ≤ 0.001
Copper 0.028	pH-value 4.8

Table 3

**Flue system**

<b>HORIZONTAL 100 mm - Standard</b>			
<b>Overall Diameter of Duct</b>	<b>mm</b>	<b>100</b>	<b>Max. 4 m</b>
<b>Flue Terminal / Duct Assembly Length</b>	<b>mm</b>	<b>600</b>	
<b>Extension Duct Length</b>	<b>mm</b>	<b>1000</b>	

Table 4

<b>ALTERNATIVE HORIZONTAL 125 mm FLUE SYSTEM</b>			
<b>Overall Diameter of Duct</b>	<b>mm</b>	<b>125</b>	<b>Max. 13 m (including turret)</b>
<b>Flue Terminal / Duct Assembly</b>	<b>mm</b>	<b>1030</b>	

Table 5

<b>VERTICAL 125 mm FLUE SYSTEM</b>			
<b>Overall Diameter of Duct</b>	<b>mm</b>	<b>125</b>	<b>Max. 13.7 m</b>
<b>Flue Terminal / Duct Assembly</b>	<b>mm</b>	<b>1360</b>	

Table 6

Elbow - 90 ° Equivalent length 2 m  
 Bend - 45 ° Equivalent length 1 m

**Gas supply**

<b>Total length of gas supply pipe (metres)</b>			<b>Pipe diameter (mm)</b>
<b>3</b>	<b>6</b>	<b>9</b>	
<b>Gas discharge rate (m<sup>3</sup>/h)</b>			
<b>8.7</b>	<b>5.8</b>	<b>4.6</b>	<b>22</b>
<b>18.0</b>	<b>12.0</b>	<b>9.4</b>	<b>28</b>

Table 7

**Domestic water performance**

Domestic Water Flow Rate l/min	Temperature Rise	30 °C	
	Temperature Rise	35 °C	
	Temperature Rise	40 °C	
Maximum Mains pressure		bar	10.0
Minimum Mains pressure		bar	0.2

Table 8

**2 Installation regulations**

Gas Safety (Installation & Use) Regulations 1998: All gas appliances must be installed by a competent person. Failure to install correctly could lead to prosecution.

The manufacturers notes must not be taken, in any way, as overriding statutory obligations.

The appliance must be installed in accordance with the current IEE Wiring Regulations, local Building Regulations, Building Standards (Scotland) (Consolidation), bye-laws of the local Water Company, Health and Safety Document 635 (Electricity at Work Regulations 1989) and any other local requirements.

Product Liability regulations indicate that, in certain circumstances, the installer can be held responsible, not only for mistakes on his part but also for damage resulting from the use of faulty materials. We advise the installer to avoid any risk by using only quality approved branded fittings.

The relevant British Standards should be followed i.e.

- BS 6798: Specification for the installation of gas fired hot water boilers of rated input not exceeding 60kW
- BS 5449: Central Heating for Domestic Premises
- BS 5546: Installation of gas hot water supplies for domestic purposes
- BS 5440:1: Flues and ventilation for gas appliances of rated input not exceeding 70 kW (net): Flues
- BS 5440:2: Flues and ventilation for gas appliances of rated input not exceeding 70 kW (net): Air Supply
- BS 6891: Installation of low pressure gas pipework installations up to 28mm (R1).
- BS 7074:1: Code of practice for domestic heating and hot water supply
- BS 7671: Requirements for Electrical Installation.

**These instructions must be followed.**

### 3 Installation



- ▶ Always turn off the gas cock before carrying out any work on components which carry gas.



Fixing of the appliance, gas and flue connections, commissioning of the system and electrical connections may only be carried out by competent persons authorised by CORGI.

#### 3.1 Important remarks

- ▶ Appliance should only be installed in sealed central heating systems.
- ▶ To avoid gas formation in the system, galvanised radiators or pipes must not be used.
- ▶ If a room thermostat is used: do not fit a thermostatic radiator valve on the radiator in the primary room.
- ▶ Add a suitable anti-freeze fluid compatible with aluminium to the water in the central heating system. Suitable products are available from Betz-Dearborn Tel.: 0151 4209563 and Fernox Tel.: 01799 550811.
- ▶ In our experience, the addition of sealing agents to the water in the central heating system can cause problems (deposits in the heat exchanger). For that reason we advise against their use.

#### 3.2 Sealed systems

The appliance must not be operated without the system being full of water, properly vented and pressurised.

The expansion vessel has a volume of 10 litres and is charged to a pressure of 0.75 bar.

The water capacity of the system is shown in table 11, page 27. If a greater capacity is required then an additional expansion vessel must be fitted into the system return as close to the appliance as possible. The system pressure can be set up to a maximum of 1.5 bar with 1 bar being the normal setting.

If the system pressure is greater than 2.65 bar when the appliance is operating at maximum temperature then an additional expansion vessel must be fitted into the system return as close to the appliance as possible.

The filling point must be at low level and arranged as shown in figs. 5 and 8.

The pressure relief valve is set to operate at 3 bar.

There must be no connection to the mains without the approval of the local water company. All connections in the system must be capable of withstanding a pressure of up to 3 bar and the radiator valves conform to the requirements of BS 2767:10.

If Thermostatic Radiator Valves are fitted then it is recommended that the primary radiator (where the room thermostat is sited) is left open.

Repeated venting probably indicates a leak and this must be rectified to ensure the proper operation of the appliance.

**No galvanised radiators or pipes must be used.**

**If any system water treatment is required then use only products suitable for use with Aluminium shall be used i.e Fernox- Copal or Superconcentrate or Sentinel X100, in accordance with the manufacturers instructions. The use of any other substances will invalidate the guarantee. The pH value of the system water must be less than 8 or the appliance guarantee will be invalidated.**

Suitable products are available from Betz-Dearborn Tel.: 0151 4209563 and Fernox Tel.: 01799 550811

A drain cock to BS2879 must be fitted to the lowest point of the system.

**IMPORTANT: Check that no dirt is left in the water pipework as this could damage the appliance. Thoroughly flush the heating system and the mains water supply before fitting the appliance to the wall in accordance with the recommendations of BS7593:1992.**

**Note:**  
A drain cock should be fitted at the lowest point of the heating circuit and beneath the appliance

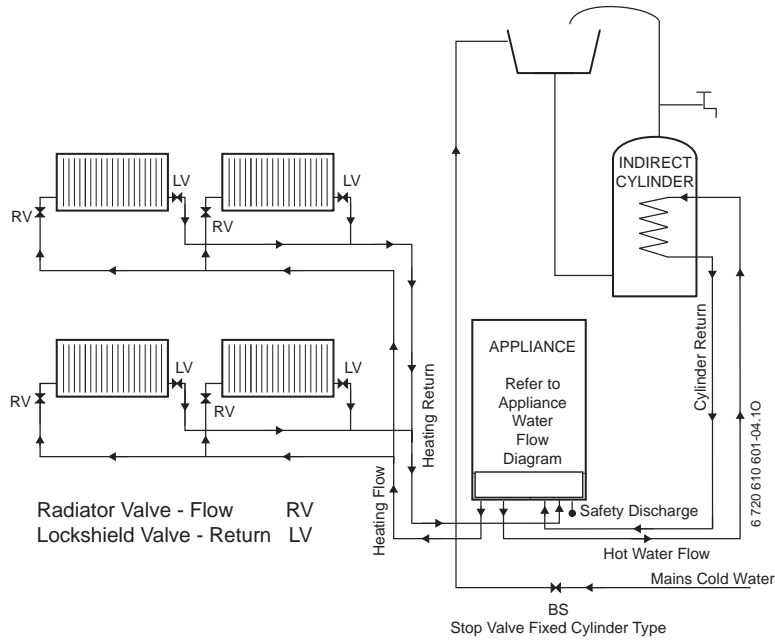

Fig. 5 System layout if using built-in diverter valve

**Note:**  
A drain cock should be fitted at the lowest point of the heating circuit and beneath the appliance

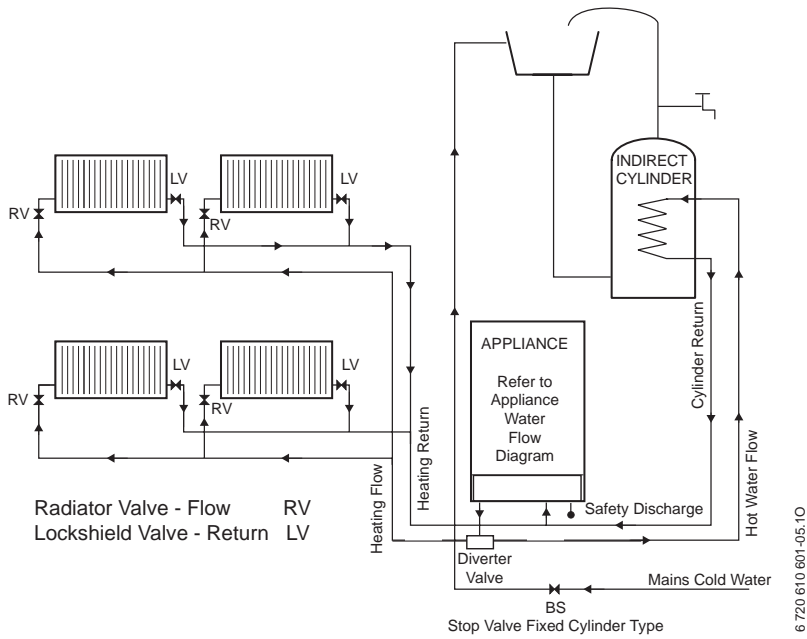

Fig. 6 System layout if using external diverter valve

**Note:**  
A drain cock should be fitted at the lowest point of the heating circuit and beneath the appliance

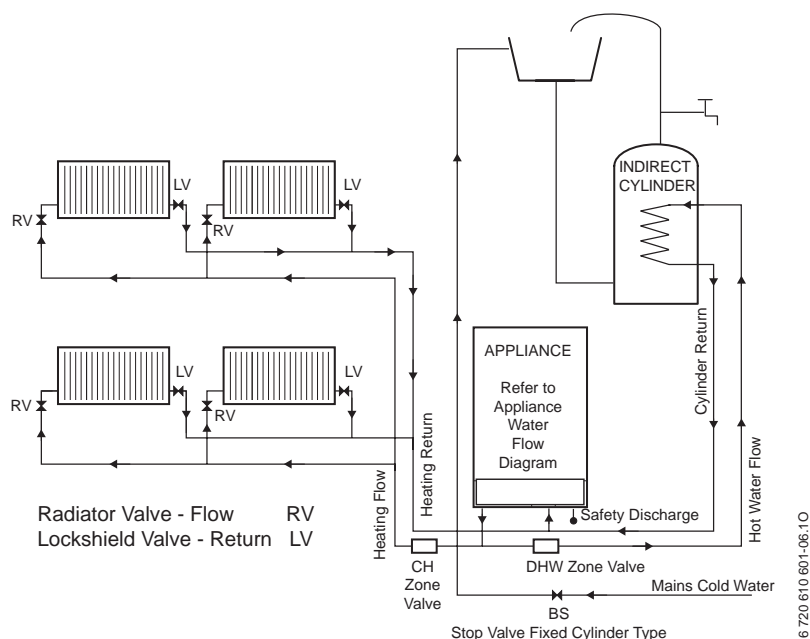

Fig. 7 System layout if using twin zone valves (S) plan

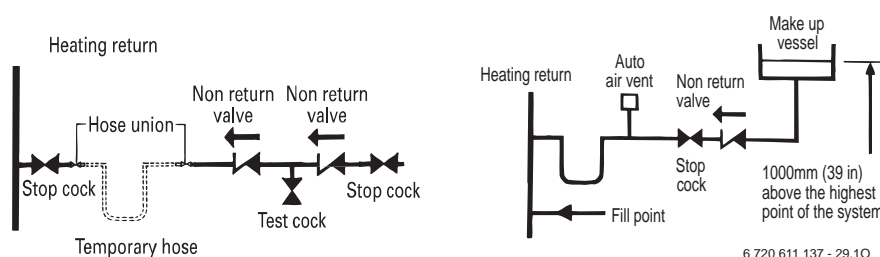

Fig. 8

### 3.3 Siting the appliance

#### Regulations concerning the Installation Site

- ▶ Relevant national regulations must be complied with section 3.7.1.
- ▶ Consult the installation instructions for details of minimum clearances required.

#### Combustion air

In order to prevent corrosion, the combustion air must not contain any corrosive substances.

Substances classed as corrosion-promoting include halogenated hydrocarbons which contain chlorine and fluorine compounds and are contained in some solvents, paints, adhesives, aerosol propellants and household cleaners, for example.

#### Surface temperature

The max. surface temperature of the casing and the flue is less than 85 °C.

This means that, no special safety precautions are required with regard to flammable building materials and fitted furniture. The specified clearances must be maintained.

#### Cupboard/Compartment

The appliance can be installed in a cupboard/compartment need for airing clothes providing that the requirements of BS6798 and BS5440:2 are followed. The low casing losses from the appliance eliminate the need for ventilation openings in the compartment.

### 3.4 Pre-piping the system

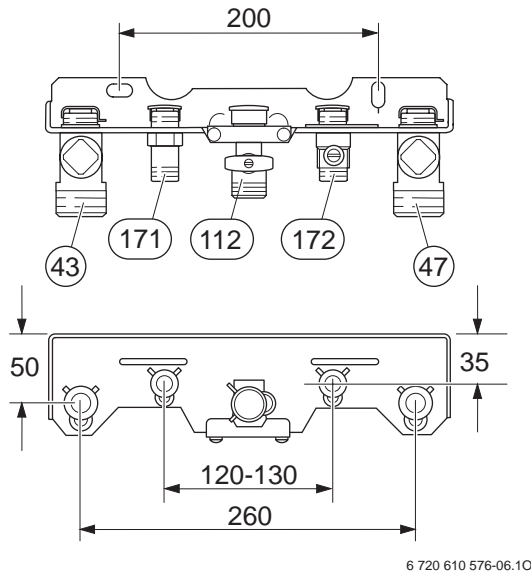

Fig. 9 Manifold (accessory)

- 43 CH flow
- 47 CH return
- 112 Gas cock
- 171 Domestic hot water
- 172 Cold water inlet

- ▶ A drain tap should be fitted at the lowest point of the central heating system.
- ▶ WRAS approved filling loop must be fitted.

#### Condensate Termination and Route

The condensate connection on the Worcester Bosch appliances is in 22 mm plastic. The pipe should be extended and run away from the appliance with a constant fall of 2.5° or 40 mm in every metre.

The condensate pipe can terminate into any of four areas:

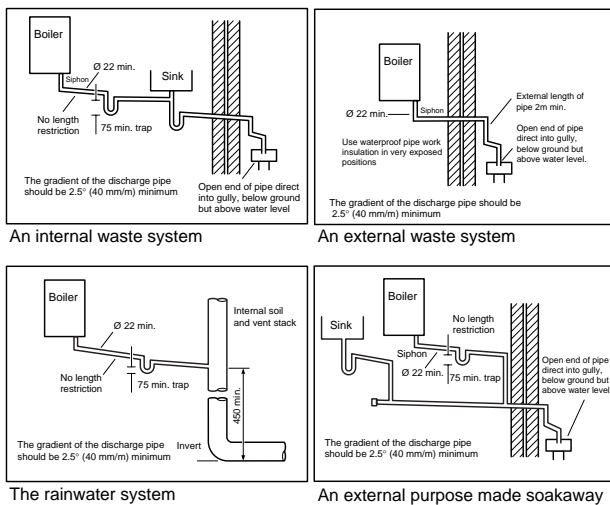

Fig. 10

Whilst all of the above methods are acceptable it is always the best practice to terminate the condensate pipe

via an internal waste system. This will eliminate the need for any external condensate pipe runs which can be susceptible to freezing in extreme weather.

#### External condensate pipework

All Worcester Bosch condensing boilers have within a syphonic condensate trap. Rather than the condensate constantly dripping into the discharge pipe, the condensate is collected into a trap which releases it in 100 ml quantities.

This will help prevent freezing occurring.

If there is no alternative and the condensate pipe has to be externally run, the following should be considered:

- The pipe run should take the shortest practical route.
- The pipework should be insulated with weather resistant insulation.
- The pipe should terminate as close as possible to the ground or drain, whilst still allowing the condensate to safely disperse. This would prevent wind blowing up the pipe.
- The pipework should be installed with the minimum of horizontal runs and with a downward slope of at least 2.5°.

### 3.5 Fitting the appliance



**Benchmark:** For optimum performance after installation, this boiler and its associated central heating system must be flushed in accordance with the guidelines given in BS5793:1992 "Treatment of water in domestic hot water central heating systems".

#### Unpacking

#### IMPORTANT HANDLING INSTRUCTIONS

- ▶ Two people should transfer the packaged appliance from the van to the point of installation
- ▶ Open the top of the carton, remove and place the component tray and both side bars of the wall mounting frame to one side
- ▶ Lie the packaged appliance on its back. (The back has "TRUCK HERE" printed on the carton)
- ▶ One person firmly holds the packaging while the other straddles the boiler and slides it from the packaging
- ▶ Two persons are then required to lift one end and stand the appliance upright with the flue at the top

#### Additional requirements for roof space installation

- ▶ Two people should use two step ladders and share lifting the unpacked boiler up to the loft hatch

- ▶ Where the boiler enters the loft space, tilt and slide the boiler on its back to the point of installation

Check the contents against the packing list.

### Removing the outer case



The outer case is secured against unauthorised removal by two clips (electrical safety).

- ▶ Always secure the outer case with those screws again refitting.

- ▶ Unscrew the screws.
- ▶ Slide the outer case upwards and then forwards to remove.

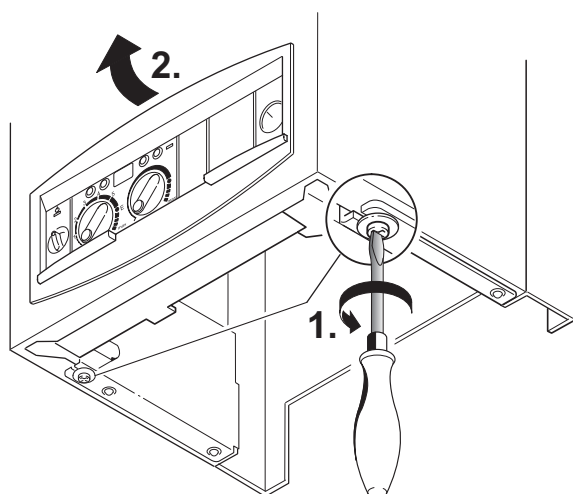

6 720 610 332-07.2R

Fig. 11

### Fixing the appliance

- ▶ Fit the washers onto the gas and water connections.
- ▶ Lift the boiler onto the wall-mounting frame. The lugs pass through the rectangular holes in the boiler back panel.
- ▶ Take care not to disturb the washers on the connections.

### Connecting the flue duct

- ▶ Fit flue duct connector onto appliance flue spigot.
- ▶ Secure with screws supplied.

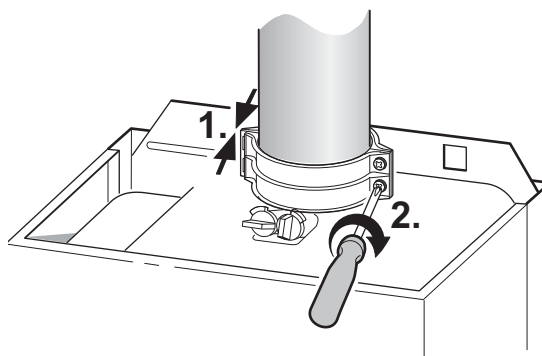

Fig. 12

- ▶ For remaining installation of flue assembly, refer to the relevant installation instructions.

### 3.6 Checking the connections

#### Water connections

- ▶ Check that the O-rings or seals are in place before tightening the connection.
- ▶ Turn on the service valves for central heating flow and return and fill the heating system through a WRAS approved filling loop.
- ▶ Check all seals and unions for leaks (testing pressure max. 3.0 bar as indicated by pressure gauge).
- ▶ Turn on cold water service cock and fill hot water system (testing pressure max. 10 bar).
- ▶ Check all connections for leaks.

#### Gas supply pipe

- ▶ Check that the seal is in place before tightening the connection.
- ▶ Turn off gas cock to protect gas valve against damage from excessive pressure.
- ▶ Check gas supply pipe.
- ▶ Release the pressure on the gas supply pipe.

### 3.7 Flue Systems

The only flue systems that may be used are those supplied with the boiler.

The flue system must be installed in accordance with the requirements of BS5440:1.

#### Standard 100 mm flue system

The standard concentric flue system provides for a horizontal length of up to 4 m. Full instructions for fitting this flue are in Subsection 3.7.2 "Installation of the flue".

#### Alternative 125 mm diameter flue systems

Installation instructions for the alternative flue systems are sent with the appropriate flue kit.

Systems are available to give a maximum horizontal length of 13 m.

A vertical flue system up to a height of 13.7 metres is available.

45° and 90° flue bends can be used with a corresponding reduction in flue length of 2m for each 90° bend and 1 m for each 45° bend used.

**IMPORTANT:** Any horizontal flue system fitted to a condensing boiler must incline from the appliance at an angle of 3° (30 mm per metre length) to prevent condensate dripping from the flue terminal.

Note, the standard 100mm horizontal flue requires only a 0.5° incline from the boiler as the inner exhaust pipe is inclined at 2.5° inside the outer pipe.

**This means that the clearance above the appliance must be increased to match the duct length. Refer to fig. 1 on page 5.**

### 3.7.1 Siting the Flue Terminal

The flue must be installed in accordance with BS 5440:1 and the Building Regulations. Flue terminals in carports and under balconies are to be avoided. The terminal must be positioned so that it does not cause an obstruction nor the combustion products a nuisance. See fig. 13 and table 9.

The terminal will, at times, give out a plume of water vapour and consideration must be given to this when choosing a terminal position. Keep clear of security

lighting, activated by passive infra-red sensing heads. If the terminal is less than 2 m above a surface to which people have access then a guard must be fitted. The guard must be evenly spaced about the terminal with a space of 50 mm in each direction and fixed with plated screws.

A guard Type K6 for the standard horizontal flue, can be obtained from Tower Flue Components, Vale Rise, Tonbridge TN9 1TB.

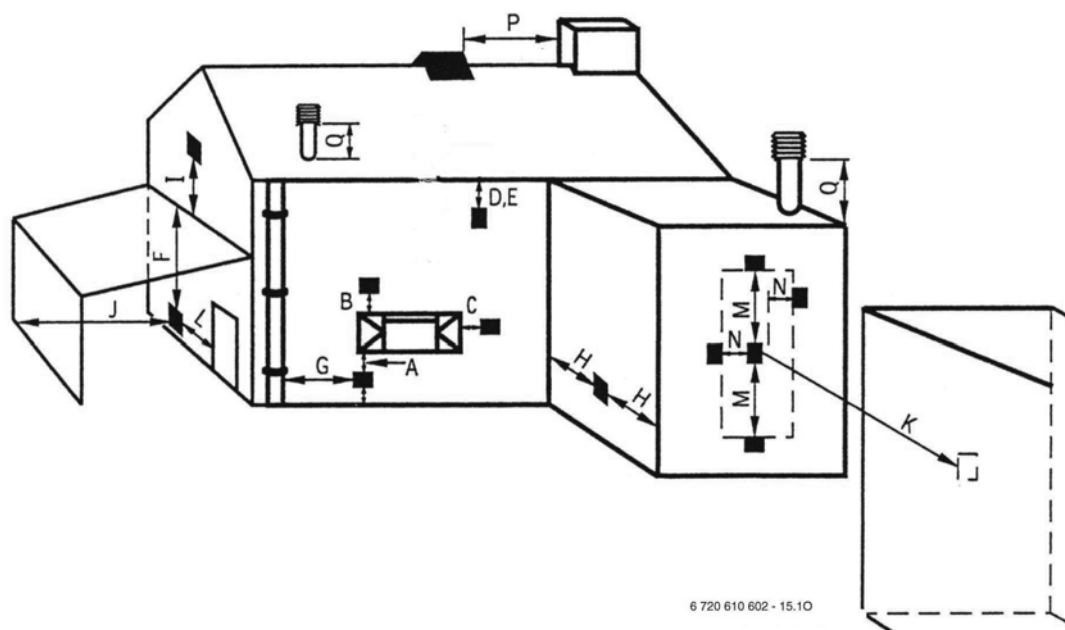

Fig. 13

#### Minimum dimensions of flue terminal positions (all types) (see fig 13. 13)

Dimension	Terminal Position (kW input expressed in net)	Balanced flues room sealed: Fanned draught
A <sup>1)</sup>	Directly below an opening, air brick, opening windows, etc.	300 mm
B <sup>1)</sup>	Above an opening, air brick, opening window, etc.	300 mm
C <sup>1)</sup>	Horizontally to an opening, air brick, opening window, etc.	300 mm
D	Below gutters, soil pipes or drain pipes	75 mm
E	Below eaves	200 mm
F <sup>2)</sup>	Below balconies or car port roof (lowest point)	200 mm
G	From a vertical drain pipe or soil pipe	150 mm
H	From an internal or external corner	300 mm
I	Above ground roof or balcony level	300 mm
J	From a surface facing the terminal	600 mm
K	From a terminal facing the terminal	1200 mm
L <sup>2)</sup>	From an opening in the car port (e. g. door, window) into the dwelling	1200 mm
M	Vertically from a terminal on the same wall	1500mm
N	Horizontally from a terminal on the same wall	300 mm
O	From the wall on which the terminal is mounted	Not applicable - Refer to separate vertical flue instructions.
P	From a vertical structure on the roof	Not applicable - Refer to separate vertical flue instructions.
Q	Above intersection with roof	Not applicable - Refer to separate vertical flue instructions.

Table 9

- 1) In addition, the terminal should not be nearer than 150 mm (fanned draught) to an opening in the building fabric formed for the purpose of accommodating a built-in element such as a window frame.
- 2) Not recommended.

**3.7.2 Installation of the flue**

The standard 100 mm diameter horizontal flue system is suitable for lengths up to 4 m.

Flues up to 650 mm do not require an extension duct assembly.

Flues between 1600 mm and 4000 mm require extension duct assemblies.

NOTE: Flue lengths between 650 mm and 730 mm cannot be accommodated. Refer to Fig. 15, 16, 17.

Standard system comprise: Flue turret - Flue turret clamp - Terminal assembly.

Extension kit comprises: Air duct - Flue duct - Duct clamp. Refer to Fig. 18.

Instructions for fitting other flue systems are packed with the relevant flue kit.

Check that the position chosen for the appliance is satisfactory Refer to Fig. 14.

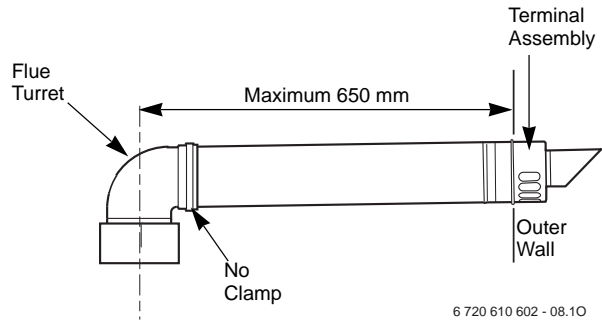

6 720 610 602 - 08.10

Fig. 15 Standard Flue

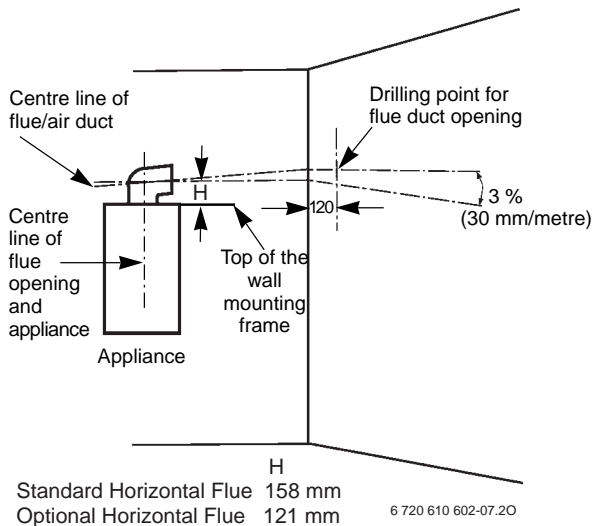

Fig. 14 Marking the position of the side flue opening

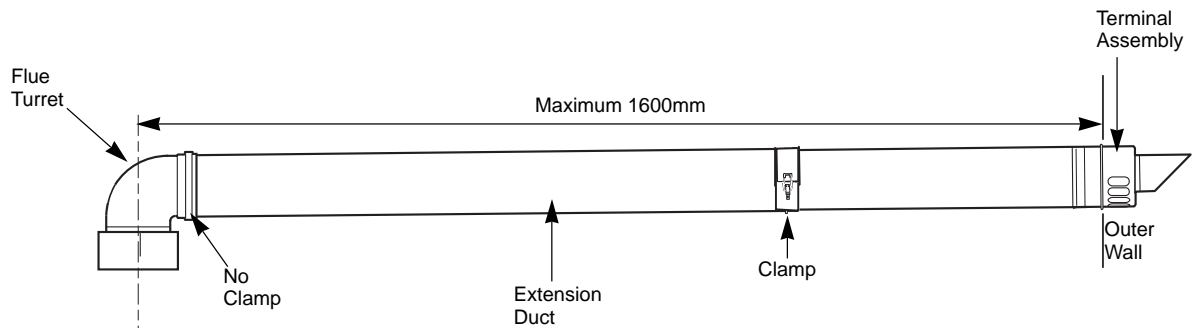
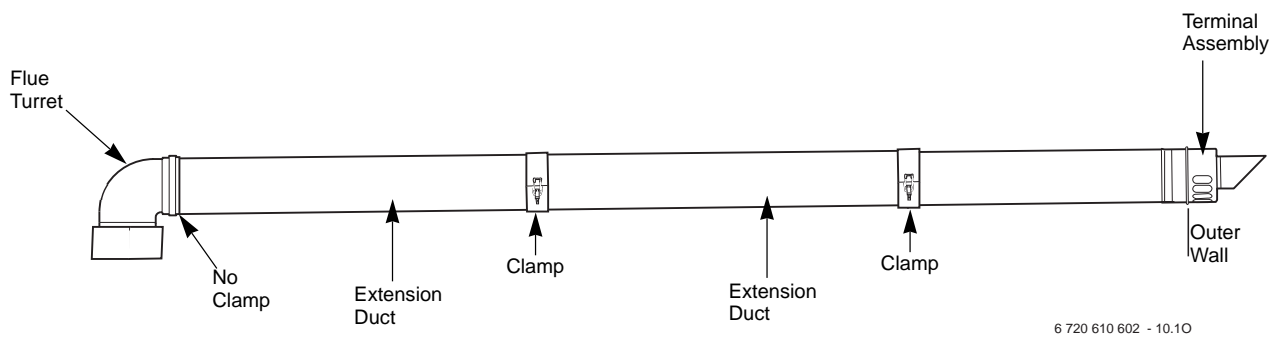
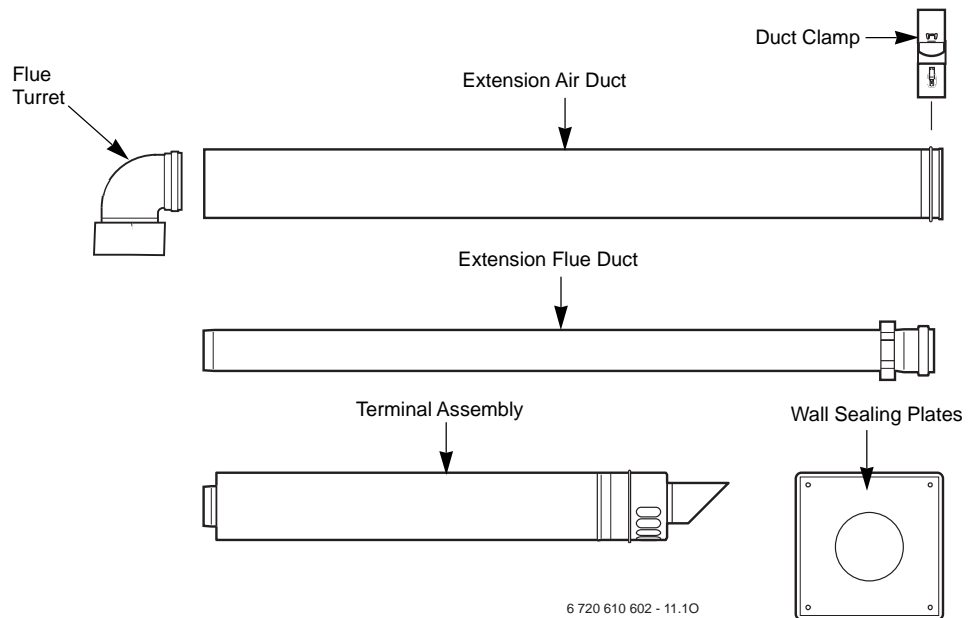

Fig. 16 Flue with one extension



6 720 610 602 - 10.10

Fig. 17 Flue with extensions



6 720 610 602 - 11.10

Fig. 18 Flue components

### 3.7.3 Flue duct preparation and assembly

Measure the flue length L. Refer to fig. 19, 20.

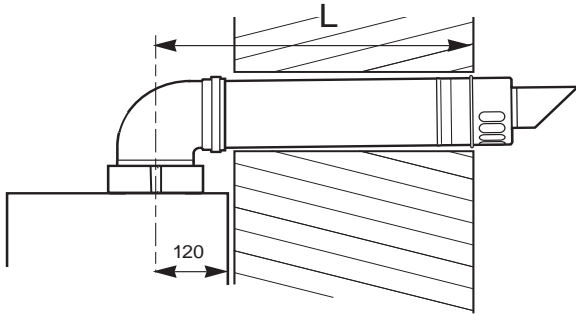

NOTE: THE FLUE MUST BE INCLINED TO THE BOILER  
6 720 610 602 - 12.10

Fig. 19 Flue length - rear

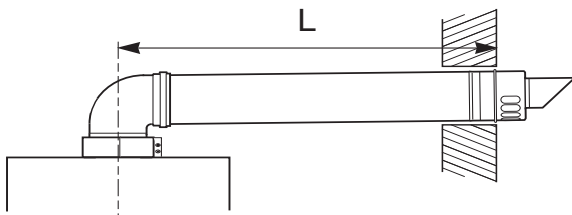

NOTE: THE FLUE MUST BE INCLINED TO THE BOILER  
6 720 610 602 - 13.10

Fig. 20 Flue length - side

Measure 'L' from the end of the metal section of the flue terminal to the centre of the flue outlet on the boiler as shown in Fig. 19 & Fig. 20 and deduct 90mm from that measurement.

Cut both inner and outer flue pipe square at the opposite end to the terminal without creasing the tubes.

Remove any burrs before fitting the terminal to the turret.

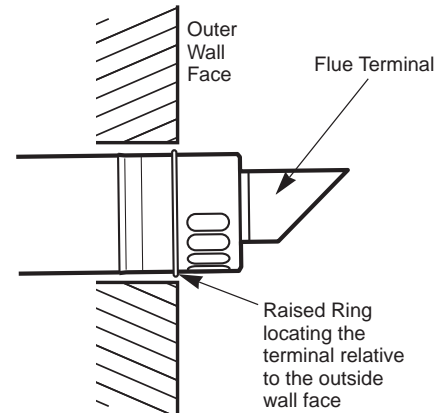

Fig. 21 Flue terminal position

Assemble flue system completely. Push the ducts fully together and clamp in the positions. The slope of the terminal outlet must face downwards.

The assembly will be made easier if a solvent free grease is lightly applied i.e. Silicone lubricant, to the male end of the ducts.

**NOTE: An inner wall sealing plate is provided which should be fitted to the ducts before assembly.**

Push the assembly through the wall and fix the turret to the appliance with the screws provided. Refer to fig. 22.

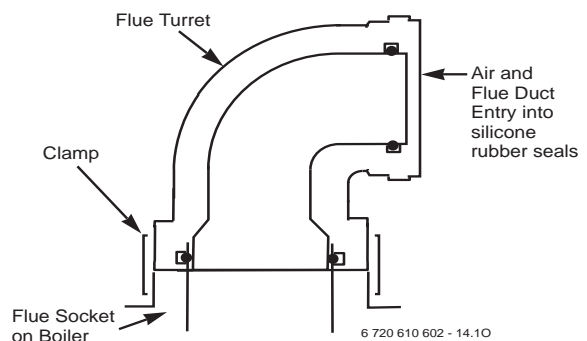

Fig. 22 Flue turret

Ensure that the turret is fully entered into the socket on the boiler.

If the terminal is within 2 m of the ground where there is access then an approved terminal guard must be fitted. The guard must give a clearance of at least 50 mm around the terminal and be fixed with corrosion resistant screws.

## 4 Electrical connections



▶ Always disconnect the power supply to the appliance at the mains before carrying out any work on the electrical systems and components.

- ▶ Allow mains cable to protrude at least 50 cm from wall.
- ▶ To maintain the splash-proof (IP) design: cut the cable grommet hole size to match the diameter of the cable, see fig. 25.
- ▶ The appliance must be earthed.
- ▶ It must be possible to completely isolate the appliance with at least 3mm contact separation in both poles.

The wiring between the appliance and the electrical supply shall comply with current IEE Wiring Regulations (and any local regulations which apply) for fixed wiring to a stationary appliance.

- Supply: 230 V ~ 50 Hz, 150 Watts
- External fuse 3 A
- Any system connected to the boiler must NOT have a separate electrical supply
- Water Protection IPX4D with DT2 programmer (7-719-002-016) or with fascia blanking plate fitted.

### 4.1 Connecting the appliance

To gain access to the mains connection remove the drop down fascia cover. The drop down cover is removed by lowering it to the horizontal position and pushing firmly upwards at the rear of the supports to release the cover. Lift cover from the appliance.

After installation (or in the event of an electrical fault) the electrical system shall be checked for short circuits, fuse failure, incorrect polarity of connections, earth continuity and resistance to earth.

- ▶ Pull out cover panel at the bottom and remove. Refer to fig. 23.

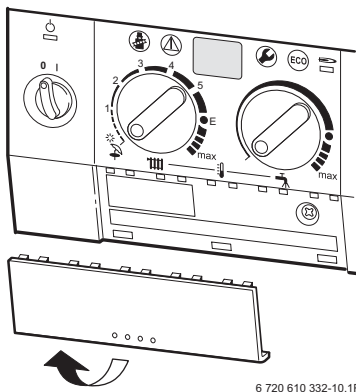

Fig. 23

- ▶ Remove screw and slide terminal cover forwards to remove. Refer to fig. 24.

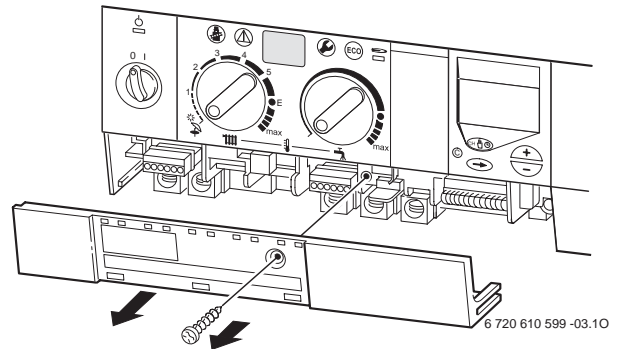

Fig. 24

- ▶ Cut cable grommet to diameter of cable.

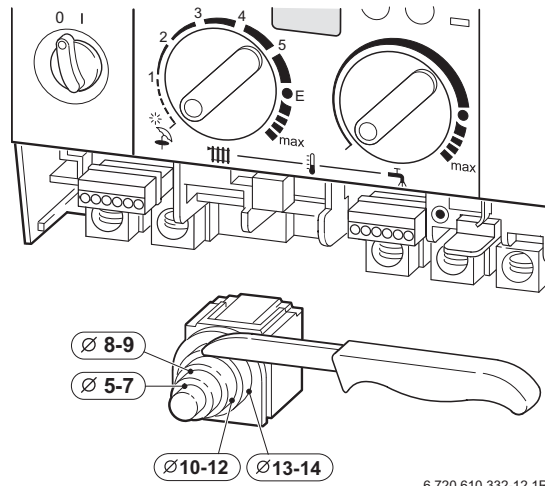

Fig. 25

- ▶ Feed cable through cable grommet and connect the mains supply cable, see fig. 26.
- ▶ Secure cable in cable grommet by means of cable grip.

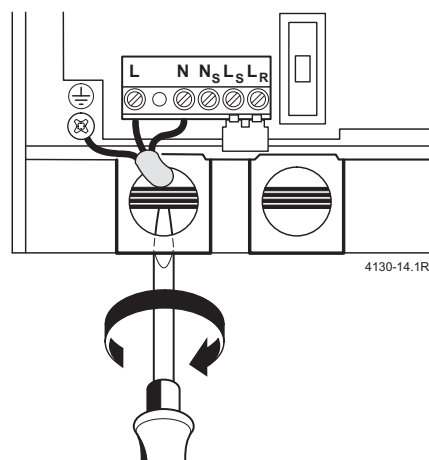

Fig. 26

## 4.2 Mains Voltage external controls connections

**NOTE:** Only double insulated controls not requiring an earth can be used

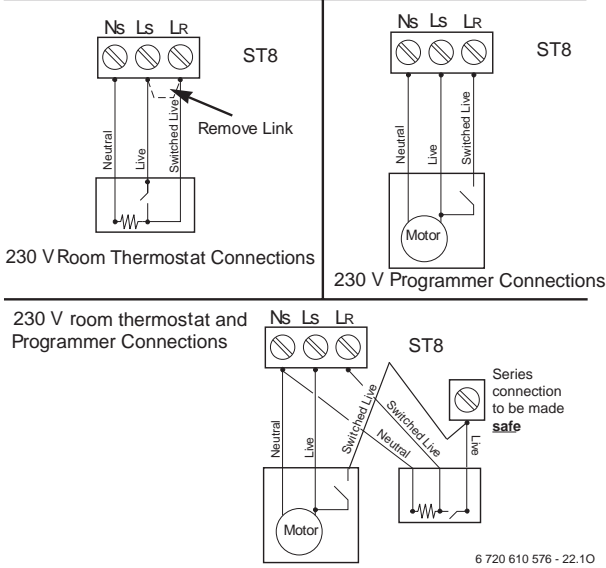

Fig. 27

**Note:** If an external timer is used then the domestic hot water pre-heat facility can only be isolated by actuating the ECO-button.

## 4.3 Wiring to your system

The following diagrams show the wiring options for your system. Any other combinations of wiring are not recommended as it would increase complexity of the system. Please also follow wiring instructions of any proprietary system. Worcester Heat Systems cannot be held responsible for any incorrect wiring external from the boiler.

**Mains electrical supply:** The boiler should be connected to the mains supply as described in Section 4.1. This also provides the electrical supply to the system. **Note:** In all cases this must be the only electrical supply to the system. This ensures the safety of a single fused supply.

**Pump:** The boiler is fitted with an internal pump.

These diagrams show connection details of two popular proprietary systems Honeywell (Tel: 08457 678999) and Invensys (Tel: 01628 546200) formerly ACL, for systems from other manufacturers instructions contact Worcester Technical Service 08705 266 241 for assistance.

Upon completion of the electrical connections check for earth continuity, correct polarisation and resistance to earth.

### 4.3.1 Pre-wired Remote S Plan

If the system is fully pre-wired at a junction box remotely from the boiler, it can be easily connected back to the Worcester System Boiler.

Drop down the facia and gain access to the boiler wiring centre as described in section 4.1.

Connect the junction box as shown (see fig. 28)

#### Important notes:

- Observe wiring details given in Section.
- Remove the pre-fitted link from L<sub>S</sub> and L<sub>R</sub>.
- If a room thermostat is required, it can be wired to the remote junction box according to the proprietary instructions.
- If a frost thermostat is required, it can be wired to the remote junction box.

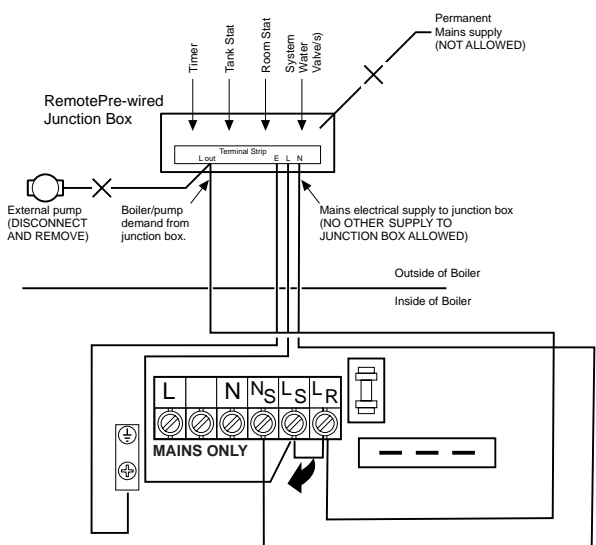
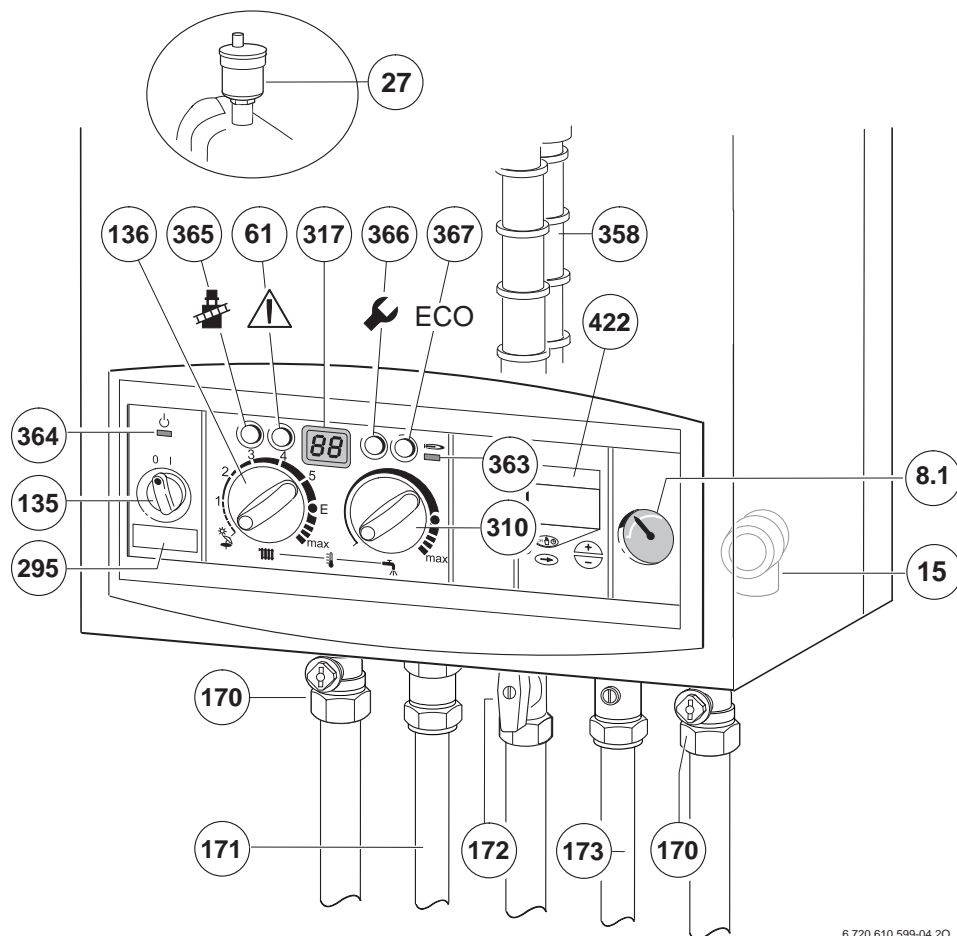

Fig. 28

## 5 Commissioning



6 720 610 599-04.20

Fig. 29

- 8.1** Pressure gauge
- 15** Safety valve
- 27** Automatic vent
- 61** Reset button
- 135** Master switch
- 136** Temperature control for central heating
- 170** Service cocks on CH flow and return
- 171** Optional cylinder flow (used only with motorised valve)
- 172** Gas cock (shown in on position)
- 173** Optional cylinder return (used only with motorised valve)
- 295** Appliance type sticker
- 310** Temperature control for hot water
- 317** Multi function display
- 358** Condensate trap
- 363** Indicator lamp for burner
- 364** Indicator lamp for power supply
- 365** "Chimney sweep" button
- 366** Service button
- 367** ECO button

### 5.1 Commissioning



**Never** run the appliance when empty or unpressurised.



The operational CO<sub>2</sub> level is set at the factory and no adjustment is necessary when installing a natural gas fired appliance.

**Benchmark Water Treatment:** For optimum performance after installation, this boiler and its associated central heating system should be flushed in accordance with the guidelines given in BS7593:1992 - Treatment of water in domestic hot water systems. Full instructions are supplied with proprietary cleansers sold for this purpose. If an inhibitor is to be used after flushing, it should be used in accordance with the inhibitor manufacturers instructions.

To drain the appliance shut the system valves and open the system drain point.

Suitable flushing agents and inhibitors are available from Betz/Dearborn Tel.: 0151 4209563, Fernox Tel.: 01799 550811 and Salamander Tel.: 0121 378 0952. Instructions for use are supplied with the these products.

- ▶ **Before commissioning, the gas supply pressure must be checked at the gas supply pressure test point (see page 6, fig. 2, item 7). Natural gas appliances must not be operated if the gas supply pressure is below 18 mbar or above 24 mbar. LPG appliances must not be operated if the supply pressure is not 37 mbar at the inlet to the appliance.**
- ▶ Unscrew the condensation trap (358) and pull out, fill with approx. 1/4 l of water and refit. Refer to fig. 29.
- ▶ Adjust charge pressure of expansion vessel to static head of the central heating system (see page 27).
- ▶ Open all system radiator valves.
- ▶ Turn on service valves (170), fill central heating system to pressure of 1 - 2 bar through the WRAS approved filling loop. Refer to fig. 29.
- ▶ Vent radiators.
- ▶ Refill heating system and set the pressure to 1 bar.
- ▶ Turn on cold water service cock (173). Refer to fig. 29.
- ▶ Check that the gas type specified on the identification plate matches that of the gas supply.
- ▶ Turn on gas cock (172). Refer to fig. 29.

## 5.2 Switching the appliance on/off

### Switching on

- ▶ Switch on the appliance at the master switch (I). The indicator lamp shows green and the display will show the central heating flow temperature, when the appliance is operating in the central heating mode.

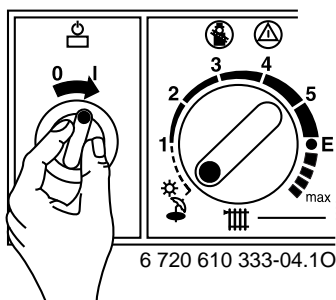

Fig. 30



If the display alternates between **-II-** and the central heating flow temperature, the trap filling programme is active.

The trap filling programme ensures that the condensation trap is filled after the appliance has been installed or after the appliance has been out of use for a long period or the mains supply has been interrupted. For that reason, the appliance remains at minimum heating output for 15 minutes.

### Switching off the appliance

- ▶ Set the master switch to (0). The green indicator lamp goes out.



▶ Always disconnect the appliance from the power supply (fuse, circuit breaker) before carrying out any work on the electrical systems or components.

## 5.3 Switching on the central heating

The central heating flow temperature is adjustable between 35°C and 88°C. Refer to table 12, page 27.

- ▶ Turn the temperature control **||||** to set the flow temperature to a level appropriate to the type of central heating system:
  - Underfloor heating: e.g. setting “3” (approx. 50°C)
  - Low-temperature heating: setting “E” (approx. 75°C)
  - Central heating systems for flow temperatures up to 88 °C: limited “max” setting for low-temperature operation (see page 27).

When the burner is alight, the **red** indicator lamp lights up.

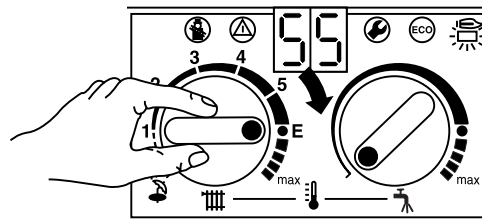

Fig. 31

## 5.4 System controls

- ▶ Set room thermostat to the desired room temperature.
- ▶ Set internal room temperature control unit (TR2), if fitted. Refer to the instructions with the control.
- ▶ Set the thermostatic radiator valves to the desired settings.

## 5.5 Appliances with optional plug-in diverter valve: Setting hot water temperature



- ▶ Do not set the temperature higher than 60°C for normal operation.
- ▶ Only use temperatures of up to 70°C temporarily for thermal disinfection purposes.

- ▶ Set the hot water temperature by means of the temperature control  on the appliance.

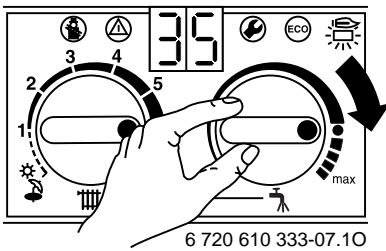

Fig. 32

Control Setting	Water Temperature
Anti-clockwise limit	approx. 10°C (frost protection)
●	approx. 60°C
Clockwise limit	approx. 70°C

Table 10

### ECO button

Pressing and holding the ECO button  switches from **Comfort mode** to **ECO-mode**.

### Comfort mode, ECO button is not lit (factory setting)

Comfort mode the hot water tank has priority. The hot water cylinder is first heated up to the set temperature. The appliance then switches to central heating mode.

### ECO mode, button is lit

In ECO mode the appliance switches between central heating mode and cylinder charging mode every 12 minutes.

## 5.6 Summer mode (hot water only)

### With room thermostat

- ▶ Turn temperature control  on the appliance anti-clockwise as far as the stop.  
The central heating is now turned off. The hot water function and the mains power supply for the heating programmer and timer remain switched on.

## 5.7 Frost protection

- ▶ Leave master switch switched on.

If the appliance is to be left for long periods switch the central heating on and set the room thermostat to 6°.

- ▶ Add a suitable anti-freeze fluid to the water in the central heating system.  
Suitable products are available from Betz/Dearborn Tel.: 0151 4209563, Fernox Tel.: 01799 550811 and Salamander Tel.: 0121 378 0952.

## 5.8 Pump anti-seize function



This function prevents the central heating pump seizing after long periods of inactivity.

Every time the pump is switched off, a timer is started. If after 24 hours the pump has not run again, it is switched on for a period of 5 minutes.

### 5.9 Fault Condition



A list of faults that may occur is given on page 43.

---

In the unlikely event of a fault occurring while the appliance is in operation:

The display then shows a fault code and the button  may also flash.

If the button  flashes:

- ▶ Press and hold the button  until the display shows “- -”.

The appliance will then start up again and the display will show the central heating flow temperature.

If the button  does not flash:

- ▶ Switch the appliance off and then on again at the master switch.  
The appliance will start up again and the central heating flow temperature will be displayed.

## 6 Individual settings

### 6.1 Mechanical settings

#### 6.1.1 Checking the size of the expansion vessel

Maximum pressure at maximum CH flow temperature is 2.5 bar. If the pressure is greater than this then fit an extra expansion vessel. Refer to table 11.

#### System Capacity - BS7074:1

Expansion Vessel Pressure and System Capacity			
Expansion Vessel	litres	10	
Expansion Vessel Charge Pressure	bar	0.75	
System pressure and capacity	1 bar	litres	82
	1.5 bar	litres	46

Table 11

#### 6.1.2 Setting the central heating flow temperature

The central heating flow temperature can be set to between 35°C and 88°C.



With underfloor heating systems, observe the maximum permissible flow temperatures.

#### Limited maximum setting for low-temperature operation

The temperature control is factory limited to setting **E**, giving a maximum flow temperature of 75°C.

Adjustment of the heating output to the calculated heat demand is not required by the heating systems regulations.

#### Removing the maximum setting limit

For heating systems which require higher flow temperatures, the maximum setting limit can be removed.

- ▶ Lift off the yellow button on the temperature control  with a screwdriver.

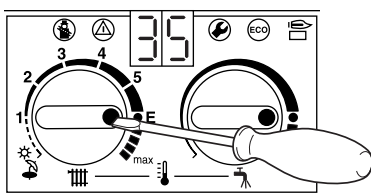

6 720 610 332-27.10

Fig. 33

- ▶ Rotate yellow button through 180° and replace (dot facing inwards).  
The CH flow temperature is no longer limited.

Control setting	CH flow temperature
1	approx. 35°C
2	approx. 43°C
3	approx. 51°C
4	approx. 59°C
5	approx. 67°C
<b>E</b>	<b>approx. 75°C</b>
max	approx. 88°C

Table 12

#### 6.1.3 Changing the heating pump characteristic

The speed of the central heating pump can be altered on the pump terminal box.



At switch position 1, maximum output is not delivered if hot water mode is active. Position 1 must not be used on combi appliances.

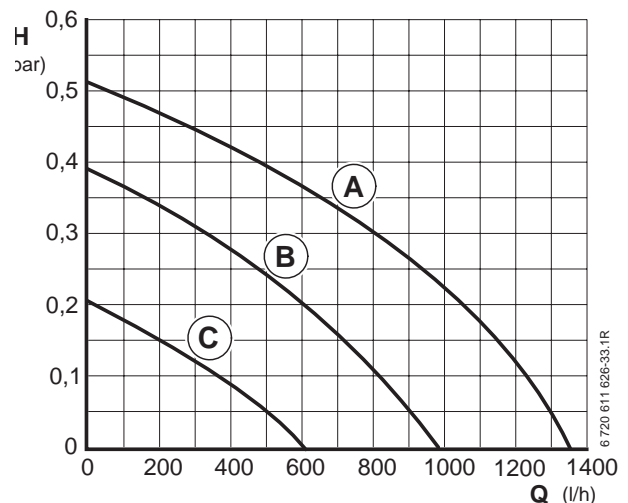

Fig. 34

- 1 Pump characteristic for switch position 1
- 2 Pump characteristic for switch position 2
- 3 Pump characteristic for switch position 3
- H Residual delivery pressure
- Q Water circulation rate

## 6.2 Settings on the Bosch Heatronic

### 6.2.1 Operating the Bosch Heatronic

The Bosch Heatronic enables easy setting and checking of a large number of appliance functions.

This description is limited to those functions required for commissioning.

For a full description of all available functions, please refer to the Service booklet for the Engineer, order no. 7-181-465-348.

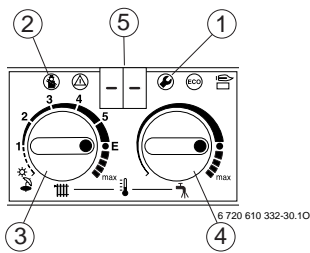

Fig. 35 Appliance controls

- 1 Service button
- 2 "Chimney sweep" button
- 3 Temperature control for central heating
- 4 Temperature control for hot water
- 5 Display

#### Selecting service function:

**i** Note the positions of the temperature controls and . After completing the settings, return the temperature controls to their original positions.

The service functions are subdivided into two levels: **Level 1** comprises service functions up to function **4.9**, while **Level 2** consists of the service functions from **5.0** upwards.

- ▶ To select a service function on Level 1: press and hold the button until the display shows - -.
- ▶ To select a service function on Level 2: press and hold the buttons and simultaneously until the display shows = =.
- ▶ Then turn the temperature control to select the required function.

Service function	Code no.	See page
Pump control mode	<b>2.2</b>	28
Anti-cycle time	<b>2.4</b>	28
Max. CH flow temperature	<b>2.5</b>	29
Switching difference	<b>2.6</b>	29
Max. heating output	<b>5.0</b>	29

Table 13

The service function **5.0** may be reset.

### Entering a setting

- ▶ To enter the setting for a function, turn the temperature control .

### Storing a setting

- ▶ Level 1: press and hold the button until the display shows [ ].
- ▶ Level 2: press and hold the and buttons simultaneously until the display shows [ ].

### After completing the settings

- ▶ Reset the temperature controls and to their original positions.

### 6.2.2 Selecting the pump control mode for central heating mode (Service Function 2.2)

**i** If an room temperature controller unit is connected, pump control mode 3 is automatically activated

The choice of settings is as follows:

- **Control Mode 1**  
**For heating equipment without a control unit.**  
The pump is controlled by the central heating flow temperature control.
- **Control Mode 2 (factory setting)**  
For heating systems with room thermostat.  
The central heating flow temperature control controls only the gas, the pump is not affected. The room thermostat controls both the gas and the pump.  
The pump and fan have an overrun time of between 15 s and 3 min.
- **Control Mode 3**  
The pump is controlled by the temperature control unit (TR2). In summer mode, the pump operates only for hot water mode.

### 6.2.3 Setting the anti-cycle time (Service Function 2.4)

This service function is only active if Service Function 2.7, automatic anti-cycle time, is deactivated.

The anti-cycle time can be set to between 0 and 15 minutes (is **factory set** to 3 minutes).

If the setting 0 is entered, the anti-cycle time is inactive.

The shortest possible anti-cycle time is 1 minute (recommended for single-pipe and hot-air heating systems).

**i** If the appliance is connected to an outside-temperature controlled heating programmer, the anti-cycle time does not need to be set on the appliance and is optimised by the programmer instead.

### 6.2.4 Setting the maximum CH flow temperature (Service Function 2.5)

The maximum CH flow temperature can be set to between 35°C and 88°C (**factory setting**).

### 6.2.5 Setting the switching difference (Service Function 2.6)



If the appliance is connected to an outside-temperature controlled programmer, the programmer sets the switching difference.

It does not need to be set on the appliance.

The switching difference is the permissible divergence from the specified CH flow temperature. It can be set in increments of 1 K. The adjustment range is 1 to 30 K (is **factory set** to 0 K). The minimum CH flow temperature is 30°C.

### 6.2.6 Setting the heating output (Service Function 5.0)

The heating output can be set to any level between min. rated heat output and max rated heat output to limit it to the specific heat requirements.

The factory setting is the max. rated heat output.

- ▶ Press and hold the and buttons simultaneously until the display shows ==.
- The and buttons will light up.

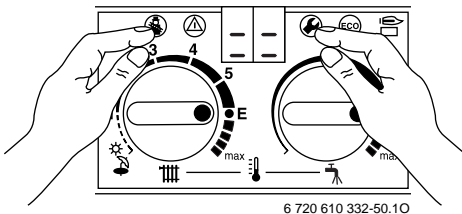

6 720 610 332-50.10

Fig. 36

- ▶ Turn the temperature control until the display shows **5.0**.
- After a short delay, the display then shows the set heating output in percent.

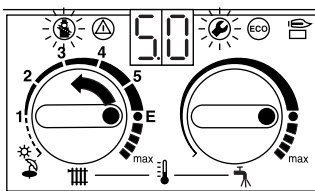

6 720 610 332-51.10

Fig. 37

- ▶ Refer to the settings tables for heating and cylinder charging output to obtain the relevant code for the desired heating output in kW (see page 45).
- ▶ Turn the temperature control until the display shows the desired code number.
- The display and the and buttons will flash.

- ▶ Measure the gas flow rate and compare with the figures specified for the code number displayed. If figures do not match, adjust the code number!
- ▶ Press and hold the and buttons simultaneously until the display shows [ ].
- The heating output is now stored.

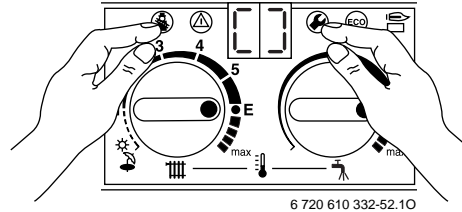

6 720 610 332-52.10

Fig. 38

- ▶ Return the temperature controls and to their original positions.
- The display will revert to the CH flow temperature.

## 6.3 Setting the gas/air ratio

The appliance is set at the factory and adjustment to the CO<sub>2</sub> settings (gas/air ratio) is only required where the appliance has been stripped down and assembled or if the fan, burner or gas valve are replaced or the appliance has been converted to a different gas type, see section 7.

## 7 Converting the appliance to different gas types

The setting is factory sealed at maximum. Adjustment to the rated heat input and min. heat input is not necessary.

### Checking the gas supply pressure

- ▶ Check the gas supply pressure at the gas supply pressure testing point.



Natural gas appliances must not be operated if the gas supply pressure is below 18 mbar or above 24 mbar. LPG appliances must not be operated if the supply pressure is below or above 37 mbar.

### Natural gas

- Appliances for **natural gas type G20** are factory set to Wobbe-Index 15 kWh/m<sup>3</sup> and 20 mbar supply pressure and sealed.

## 7.1 Setting the gas/air ratio

The gas/air ratio may only be adjusted on the basis of a CO<sub>2</sub> measurement at max. heat output and min. heat output using an electronic tester.

- ▶ Switch off the appliance at the master switch (O).
- ▶ Remove the outer case (see page 15, refer to fig. 11).
- ▶ Switch on the appliance at the master switch (I).
- ▶ Unscrew sealing plug from flue gas testing point (234). Refer to fig. 39.
- ▶ Insert testing probe about 135 mm into the flue gas testing point and seal testing point.

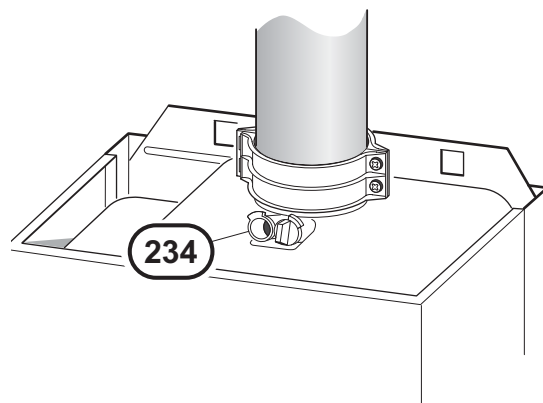

Fig. 39

- ▶ Press and hold button until the display shows --. The button will light up.

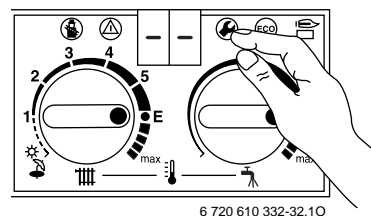

Fig. 40

- ▶ Turn the temperature control until the display shows 2.0. After a short delay, the current operating mode setting will be displayed (0. = Normal mode).

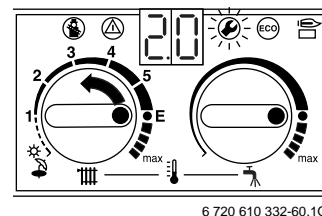



Fig. 41

- ▶ Turn the temperature control  until the display shows **2**. (= max. rated heat output). The display and the  button will flash.

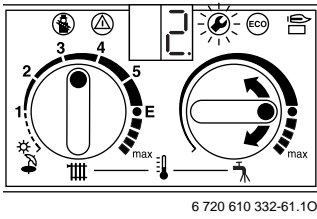

Fig. 42

- ▶ Measure the CO<sub>2</sub> level.
- ▶ Prise off the seal on the gas flow restrictor.
- ▶ Adjust the gas flow restrictor (63) to obtain the CO<sub>2</sub> level given in Table 14. Refer to fig. 43.

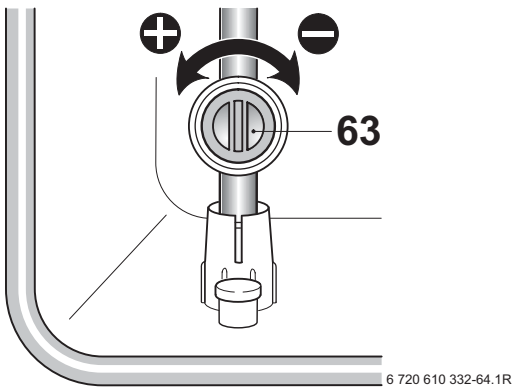



Fig. 43

Gas Type	CO <sub>2</sub> reading at max. rated heat output	CO <sub>2</sub> reading at min. rated heat output
Natural gas type G20	8.8 %	8.5 %
LPG G31 (propane)	10.5 %	10.2 %

Table 14

- ▶ Turn the temperature control  anti-clockwise until the display shows **1**. (= min. rated heat output). The display and the  button will flash.

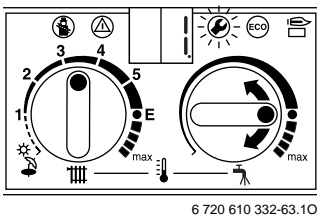

Fig. 44

- ▶ Measure the CO<sub>2</sub> level.

- ▶ Remove the seal from the gas valve adjusting screw (64) and adjust the CO<sub>2</sub> level to the figure given in Table 14 for min. rated heat output.

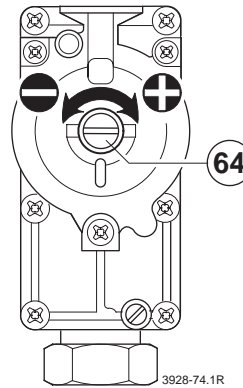









Fig. 45

- ▶ Recheck the levels at min. and max. rated heat output and re-adjust if necessary.
- ▶ Turn the temperature control  anti-clockwise as far as the stop so that the display shows **0**. (= Normal operating mode). The display and the  button will flash.
- ▶ Press and hold the  button until the display shows [ ].
- ▶ Reset the temperature controls  and  to their original positions. The display will revert to the CH flow temperature.
- ▶ Remove testing probe from the flue gas testing point (234) and refit sealing plug.
- ▶ Re-seal gas valve adjusting screw and gas flow restrictor.
- ▶ Replace outer case and secure.

## 7.2 Testing combustion air/flue gas at set heat output

### 7.2.1 Testing the O<sub>2</sub> or CO<sub>2</sub> level in the combustion air

**i** By testing the O<sub>2</sub> or CO<sub>2</sub> level in the combustion air the gas tightness of a type C<sub>13</sub> or C<sub>33</sub> **flue system** can be checked. The O<sub>2</sub> level must not be less than 20,6 %. The CO<sub>2</sub> level must not exceed 0,2 %.

- ▶ Press and hold the  button until the display shows --. "Chimney sweep" mode is now active. The  button will light up and the display shows the CH flow temperature.

**i** In "chimney sweep" mode, the appliance switches to max. rated heat output or the set heating output. You then have 15 minutes in which to measure the levels. After that, the appliance switches back from "chimney sweep" mode to normal mode.

- ▶ Remove sealing plug from combustion air testing point (234.1, fig. 46).
- ▶ Insert testing probe about 80 mm into the testing point and seal testing point.

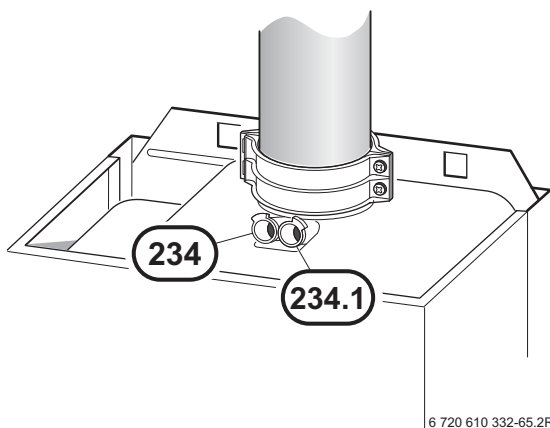





Fig. 46



- ▶ Measure O<sub>2</sub> and CO<sub>2</sub> levels.
- ▶ Refit sealing plug.
- ▶ Press and hold  button until the display shows --. The  button will stop flashing and the display shows the CH flow temperature.

### 7.2.2 Testing CO and CO<sub>2</sub>

- ▶ Press and hold the  button until the display shows --. "Chimney sweep" mode is now active. The  button will light up and the display shows the CH flow temperature.



You have 15 minutes in which to measure the levels. After that, the appliance switches back from "chimney sweep" mode to normal mode.

- ▶ Remove sealing plug from flue gas testing point (234, Fig. 46).
- ▶ Insert testing probe about 135 mm into the testing point and seal testing point.
- ▶ CO- and CO<sub>2</sub> levels.
- ▶ Refit sealing plug.
- ▶ Press and hold  button until the display shows --. The  button will stop flashing and the display shows the CH flow temperature.

## 8 Maintenance



- ▶ Always disconnect the appliance from the electrical power supply (fuse, circuit breaker) before carrying out any work on the electrical systems or components.



- ▶ Always turn off the gas cock before carrying out any work on components which carry gas.



---

There is a special Service booklet for the Engineer, order no. 7-181-465-348, available to competent persons.

---



---

All safety and control systems are monitored by the Bosch Heatronic. In the event of a component fault, the display shows a fault code.

---

- ▶ The User should be recommended to have the appliance serviced regularly by a competent person (see Maintenance Contract).
- ▶ Use only genuine spare parts
- ▶ Refer to the Spare Parts List when ordering spare parts.
- ▶ Always renew seals and O-rings removed during servicing or repair work.
- ▶ Use only the following types of grease:
  - Water valve: WRAS approved silicon based grease
  - Unions: approved sealant.
- ▶ To drain the appliance shut the system valves and open the pressure relief valve.
- ▶ Upon completion of any electrical work check for earth continuity, correct polarisation and resistance to earth.

8.1 Pre-Service Check List

		Date							
1	Call up the last fault stored by the Bosch Heatronic, Service Function <b>.0</b> , (see page 35).								
2	Check ionisation current, Service Function <b>3.3</b> , (see page 35).								
3	Perform visual check of air/flue duct. Visual check of diaphragm for soiling and splits (see page 37).								
4	Check gas supply pressure (see page 30). mbar								
5	Test combustion air/flue gas (see page 32).								
6	Check CO <sub>2</sub> setting for min./max. (gas/air ratio) (see page 30). min. % max. %								
7	Check gas and water systems for leaks (see page 16).								
9	Check heat exchanger (see page 35). mbar								
10	Check burner (see page 35).								
11	Clean condensation trap (see page 37).								
12	Check charge pressure of expansion vessel matches static head of heating system. mbar								
13	Check central heating system pressure. mbar								
14	Check electrical wiring for damage.								
15	Check heating programmer settings.								
16	Check appliances that are part of the heating system								

Table 15

## 8.2 Description of servicing operations



The combustion performance must be checked before and after any servicing work on the combustion and burner components. Refer to section 7.2.

### Check "Last fault stored":

- ▶ Select Service Function **.0** (See page 28 "Selecting Service Function").

There is a list of the fault codes in the Appendix (see page 43).

To delete "Last fault stored":

- ▶ Turn temperature control  anti-clockwise as far as the stop.
- ▶ Press and hold the  button until the display shows [ ].  
The last fault stored has now been deleted.

### Checking the ionisation current, Service Function 3.3

- ▶ Select Service Function **3.3** (See page 28 "Selecting Service Function").

If the display shows 2 or 3, the ionisation current is OK.  
If the display shows 0 or 1, the electrode assembly (32.1, page 6) must be cleaned or replaced.

### Checking the heat exchanger and burner

There is a brush for cleaning the heat exchanger  
Accessory no. 1015, order no. 7 719 002 404

- ▶ Check control pressure at rated max. heat output (Service function 2.0) at the mixer unit.



Bild 47

Control pressure	Cleaning?
≥ 4,8 mbar	Nein
< 4,8 mbar	Ja

Tab. 16

If cleaning is necessary:

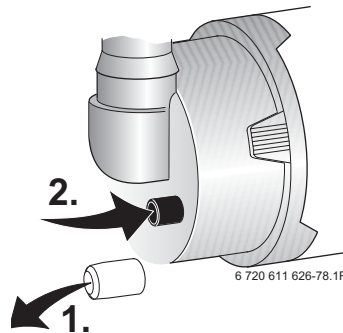
- ▶ Remove air intake pipe and disconnect gas pipe from the mixer unit.
- ▶ Remove igniter and flame monitoring electrodes.
- ▶ Unscrew nut for fixing fan plate.



Bild 48

- ▶ Remove fan assembly and hook over locating tab.

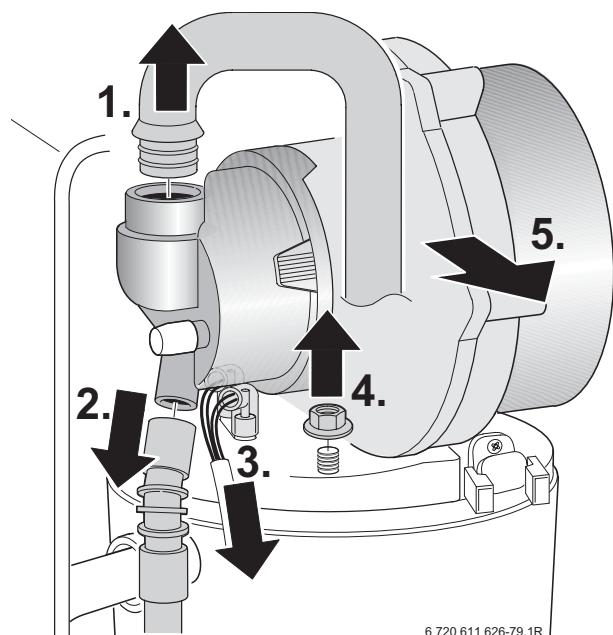

Bild 49

- ▶ Remove electrode set and seal, and remove burner.

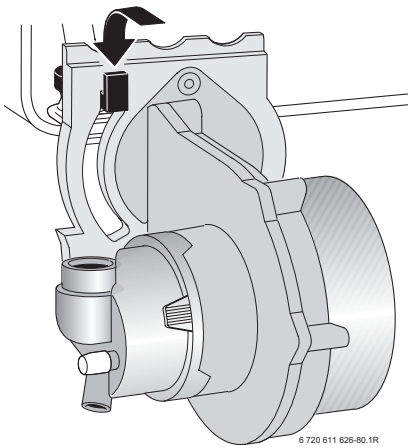

Bild 50

- ▶ Withdraw displacement cylinder.



Bild 51

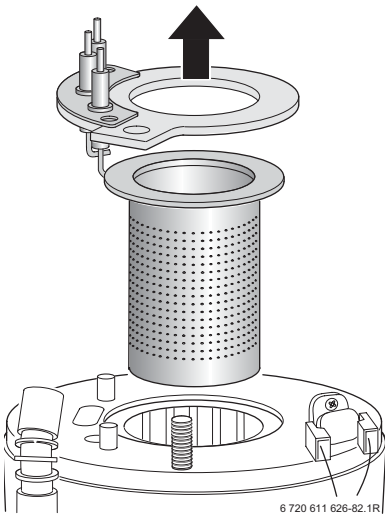

The inside of the heat exchanger can be inspected using the mirror and a torch.

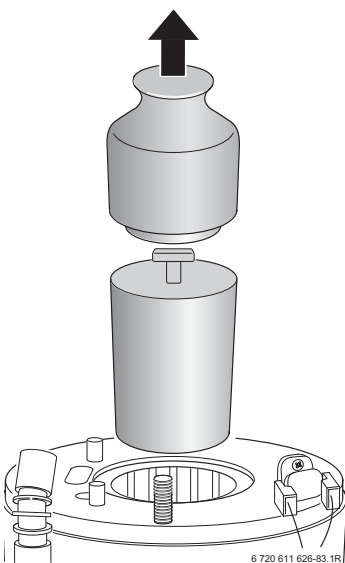

Bild 52

- ▶ Using the brush (optional accessory), clean the heat exchanger from top downwards. Remove the screws from the cleaning cover and remove cover.
- ▶ Remove the screws from the cleaning cover and remove cover.

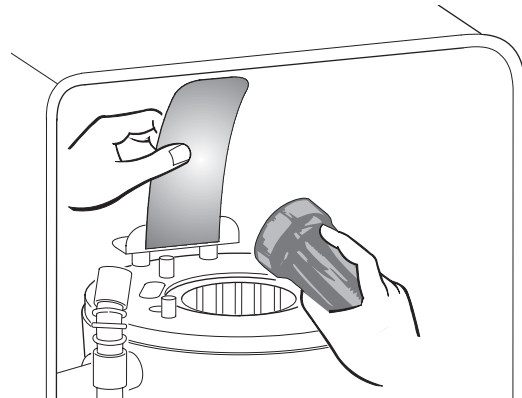

Bild 53

- ▶ Vacuum up residues and replace cleaning cover.

- ▶ Unscrew condensation trap and place suitable container underneath.

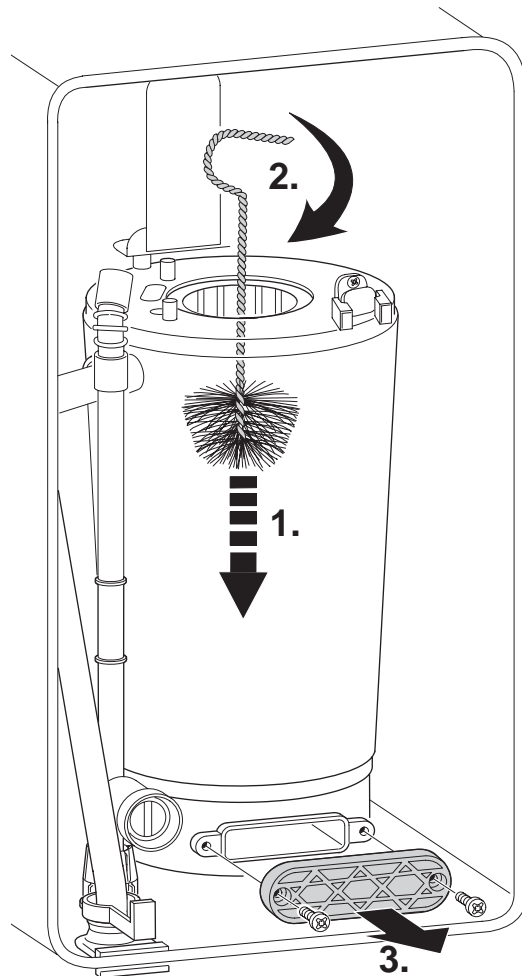
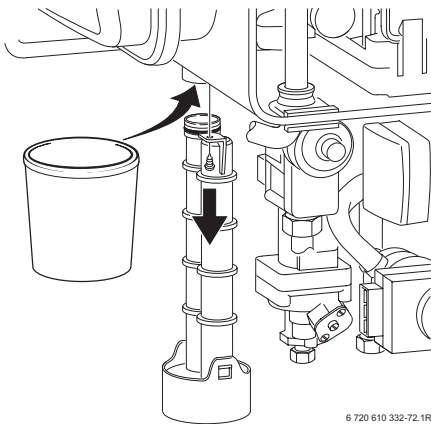

6 720 610 332-72.1R

Bild 54

- ▶ Rinse heat exchanger from top with water.

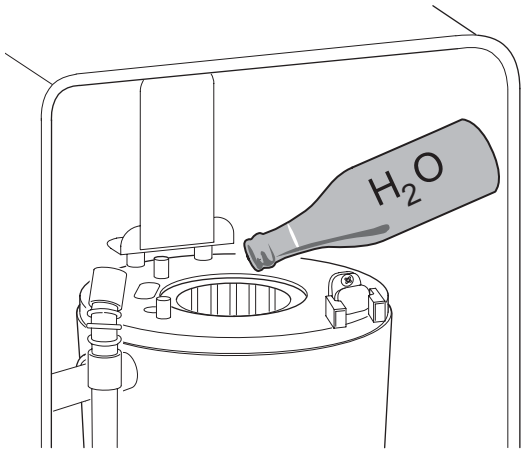

6 720 611 626-85.1R

Bild 55

- ▶ Remove cleaning cover again and clean condensate collector and condensate connection.
- ▶ Refit components in reverse order of removal.
- ▶ Re-set gas/air ratio (see page 29).

### Diaphragm in mixer unit



- ▶ Take care not to damage diaphragm (443) when removing and refitting it.

- ▶ Open mixer unit (29).
- ▶ Carefully withdraw diaphragm (443) from fan intake tube and check for soiling and splits.

Fig. 56

### Condensation trap

In order to prevent spillage of condensate, the condensation trap should be completely removed, (see page 37, fig. 54).

- ▶ Unscrew condensation trap and check connection to heat exchanger is clear.
- ▶ Remove condensation trap cover and clean.
- ▶ Fill condensation trap with approx. 1/4 l of water and refit.

### Electrode assembly

- ▶ Switch off the master switch.
- ▶ Pull off the leads from the electrodes. Refer to fig. 2.
- ▶ Unscrew the two fixing screws and carefully remove the electrode assembly. Refer to fig. 47.
- ▶ Clean the electrodes with a non-metallic brush. (The spark gap should be 4,5 mm ± 0,5 mm.)
- ▶ Replace and re-connect the assembly taking care not to mislay the inspection window.

### Expansion vessel

The expansion vessel should be checked once a year.

- ▶ Depressurise appliance.

- ▶ If necessary, adjust expansion vessel charge pressure to static head of the heating system.

### Heating system pressure



Fill the system using the WRAS approved filling loop.

- ▶ The pointer on the pressure gauge should be 1 bar.
- ▶ If the pointer is below 1 bar (when the system is cold), water should be added until the pointer is 1 bar again.
- ▶ **Max. pressure** of 2.5 bar when the heating system water is at maximum temperature must not be exceeded. If this pressure is exceeded then an extra expansion vessel must be fitted in the system return as close to the appliance as possible.
- ▶ If the system does not retain the pressure, the expansion vessel and the heating system should be checked for leaks.

### Electrical wiring

- ▶ Check the electrical wiring for physical damage and replace any damaged wires.

## 8.3 Replacement of Parts

Before changing any components check that the gas is turned off and that the appliance is electrically isolated. When necessary close the system valves and drain the appliance.

Refitting is a reverse of the procedure for removal using new seals or o-rings as appropriate.

### 8.3.1 PCB control board and transformer

- ▶ Switch off the appliance.
- ▶ Disconnect appliance from the power supply.
- ▶ Unplug all connectors from the control box (inc. keyed plug). Access is gained by removing the covers. Refer to fig. 23, 24.
- ▶ Remove screw holding power connector earth lead and remove earth lead.

- ▶ Remove two fixing screws from the control box. Refer to fig. 57.

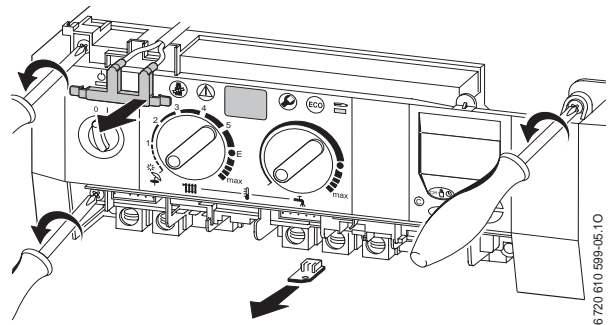

Fig. 57

- ▶ Lower the control box.
- ▶ Unscrew earth lead.
- ▶ Unscrew four fixing screws from cover plate. Refer to fig. 58.
- ▶ Prise off cover plate.
- ▶ Pull off transformer.
- ▶ Remove pcb holder.
- ▶ Remove the pcb control board.

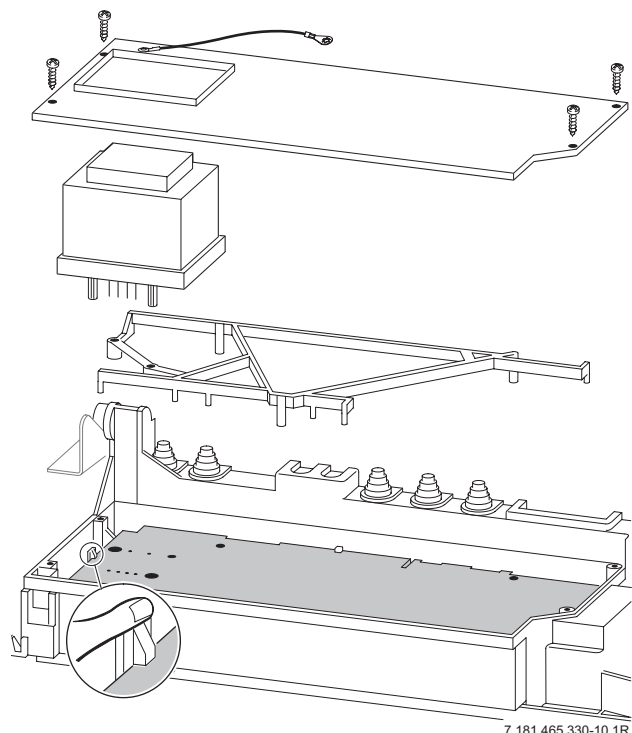

Fig. 58

### Fuses

- ▶ Remove the connections covers. Refer to fig. 23, 24.

The fuses are located adjacent to the mains connector block and connector ST18. Refer to fig. 4.

Fuse, item 312, is only replaceable by removing the pcb.

Spare fuses are fixed to the connections cover.

A fuse pack is available: Part number 8 744 503 010 0.

### 8.3.2 Pump

- ▶ Switch off the appliance.
- ▶ Disconnect the appliance from the power supply.
- ▶ Remove two switchbox fixing screws (1.). Refer to fig. 59.
- ▶ Lower switchbox (2.).
- ▶ Unscrew and remove the the siphon by releasing the jubilee clip. Refer to fig. XX.
- ▶ Unscrew the pump union nuts (5.). Refer to fig. 59.
- ▶ Carefully remove the pump and disconnect the leads.

#### Alternatively

- ▶ After removing the siphon release the four Allen screws and remove and replace the pump head.

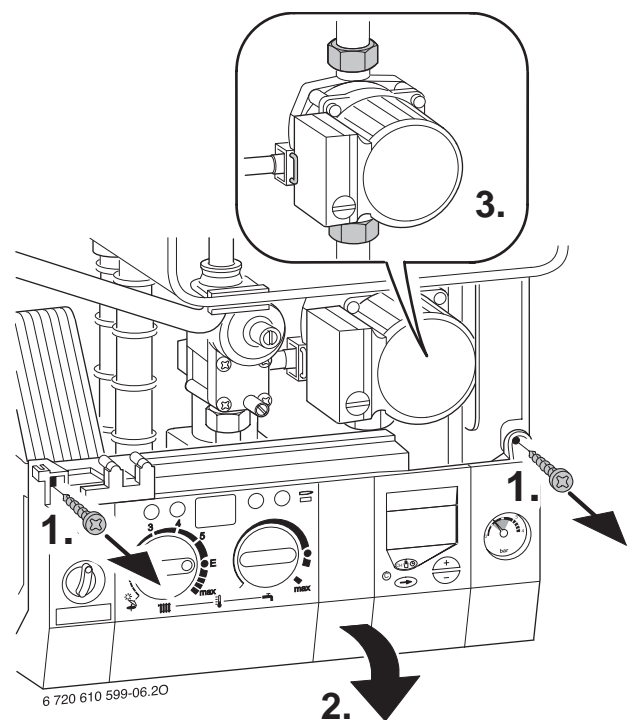
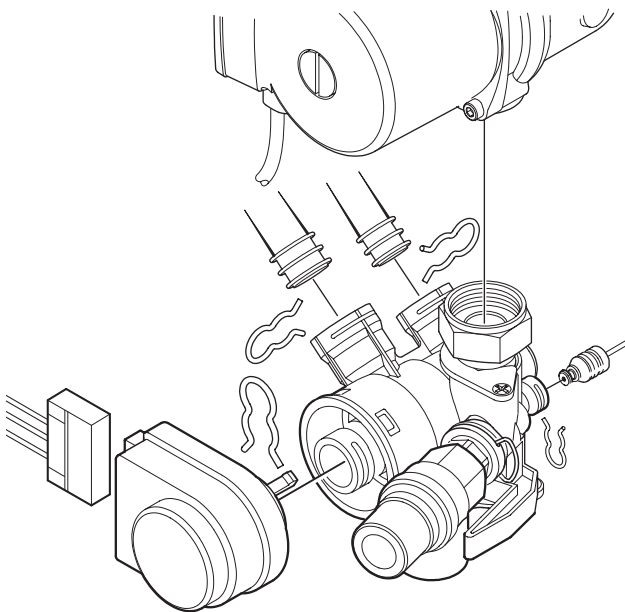

Fig. 59

### 8.3.3 Optional 3-way diverter valve

- ▶ Switch off the appliance.
- ▶ Disconnect appliance from the power supply.
- ▶ Turn off service cocks.
- ▶ Unplug connector from 3-way valve motor. Refer to fig. 60.
- ▶ Pull out retaining clip.
- ▶ Remove motor.
- ▶ Disconnect the relief valve drain.
- ▶ Disconnect the pressure gauge by withdrawing the clip and pulling out the capillary head.
- ▶ Undo pipe unions by withdrawing the clips.
- ▶ Remove 3-way valve.



7 181 465 330-12.1R

Fig. 60

After refitting:

- ▶ Fill system, bleed and re-pressurise (see Installation Instructions).

### 8.3.4 3-way diverter valve motor

- ▶ Switch off the appliance.
- ▶ Turn off the service cocks.
- ▶ Unplug connector from 3-way valve motor. Refer to fig. 60.
- ▶ Pull out retaining clip.
- ▶ Remove motor.

### 8.3.5 Sensors

- ▶ Check that the appliance is electrically isolated.

#### Central Heating Flow Temperature Sensor – Item 36, fig. 2, 57

- ▶ Pull-off the connector.
- ▶ Release the sensor clip and withdraw the sensor.
- ▶ Apply heat transfer paste to the replacement sensor.

#### Safety Temperature Limiter – Item 6, fig. 2, 57

- ▶ Pull-off the connectors.
- ▶ Unscrew the sensor.

#### Flue Temperature Limiter – Item 9, fig. 2, 57

- ▶ Pull-off the connectors.
- ▶ Unscrew the sensor.

### 8.3.6 Gas Valve

- ▶ Check that the gas cock is turned off.
- ▶ Lower the control panel. Refer to fig. 59.
- ▶ Pull off the solenoid connections at the rear of the valve.
- ▶ Undo the union, within the inner casing, securing the valve to the gas/air tube. Refer to fig. 61.
- ▶ Remove the white plastic cap from the gas valve.
- ▶ Release the gas inlet union at the manifold assembly.
- ▶ Unscrew the two screws securing the gas valve assembly bracket to the back panel and withdraw the assembly.
- ▶ Transfer the bracket and inlet pipe assembly to the new gas valve.
- ▶ Check for gas soundness when the new gas valve has been fitted.
- ▶ Recheck the combustion performance as described in section 7.1.

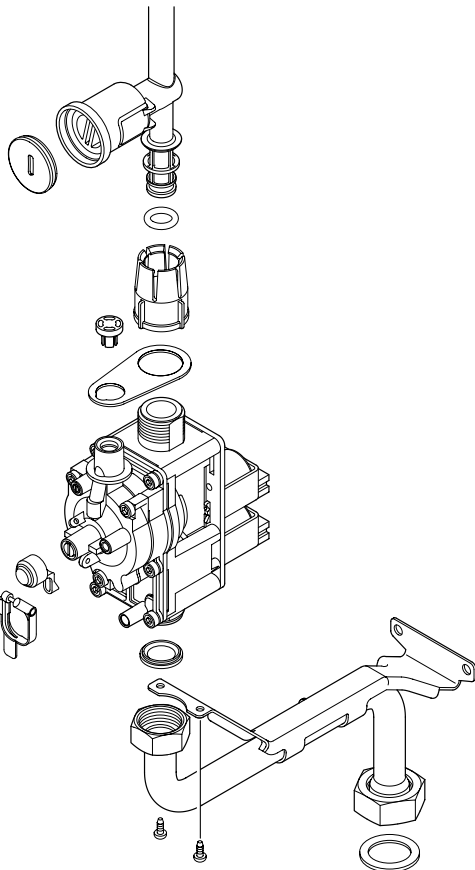

6 720 610 602 - 04.10

Fig. 61

### 8.3.7 Electrode assembly

- ▶ Refer to section 8.2.
- ▶ Use a new seal if the existing seal is damaged.

### 8.3.8 Pressure gauge

- ▶ Drain the appliance.
- ▶ Lower the fascia. Refer to fig. 59.
- ▶ Twist the pressure gauge head anti-clockwise to release it from the casing. Refer to fig. 2.
- ▶ Disconnect the capillary head from the rear of the diverter valve by withdrawing the clip and pulling out the head. Refer to fig. 60.

### 8.3.9 Expansion vessel

- ▶ Drain the appliance.
- ▶ Undo the union connection at the base of the vessel. Refer to fig. 2.
- ▶ Unscrew the top and bottom fixing screws and remove the vessel.
- ▶ Set the pressure of the new vessel to that required by the system.

### 8.3.10 Pressure Relief Valve

- ▶ Drain the appliance.
- ▶ Disconnect the drain pipe from the valve. Refer to fig. 29.
- ▶ Pull-out the clip securing the valve.
- ▶ Pull-out the valve.
- ▶ Ensure that the replacement valve is fully entered before fitting the clip.

### 8.3.11 Burner

- ▶ Refer to section 8.2.

### 8.3.12 Primary Heat Exchanger

- ▶ Drain the appliance.
- ▶ Check that the gas supply is turned off.
- ▶ Check that the appliance is electrically isolated.
- ▶ Remove the fan assembly complete with the gas/air tube and mixer assembly. Refer to section Bild 48.
- ▶ Remove the burner. Refer to section 8.2.
- ▶ Disconnect the sensors. Refer to section 8.3.5.
- ▶ Undo the central heating flow union.
- ▶ Undo the top connection of the pump. Refer to fig. 59.
- ▶ Undo the grey plastic cap, next to the top pump connection at the base of the heat exchanger.
- ▶ Unscrew and remove the condensate trap. Refer to section 8.2.
- ▶ Unscrew and remove the two screws securing the heat exchanger top bracket to the rear panel.
- ▶ Lift up the flue duct, item 271, refer to fig. 2.
- ▶ Pull forward from the top and lift the heat exchanger from the casing.
- ▶ Transfer components, as necessary, to the new heat exchanger.

- ▶ Ensure that all the seals are in place and all of the connections are tight before re-commissioning the appliance.

*Fig. 62*

## 9 Appendix

### 9.1 Fault Codes

More detailed fault finding procedures are described in the Service booklet for the Engineer number 7 181 465 346.

Display code	Description	Remedy
<b>A8</b>	Break in communication	Check connecting lead to programmer
<b>AC</b>	Module not detected.	Check connecting lead between TA211E/ TR212E and Heatronic
<b>b1</b>	Keyed plug not detected.	Insert keyed plug correctly, test and replace if necessary.
<b>C1</b>	Fan speed too low.	Check fan lead and connector, and fan; replace as necessary.
<b>d3</b>	Jumper 8-9 not detected.	Connector not connected, link missing, under-floor heating limiter tripped.
<b>E2</b>	CH flow NTC sensor defective	Check CH flow NTC sensor and connecting lead.
<b>E9</b>	Safety temp. limiter in CH flow has tripped.	Check system pressure, check safety temp. limiters, check pump operation, check fuse on pcb, bleed appliance.
<b>EA</b>	Flame not detected.	Is gas cock turned on? Check gas supply pressure, power supply, igniter electrode and lead, ionisation sensing electrode and lead, flue duct and CO2 level.
<b>F0</b>	Internal error.	Check electrical connector contacts, programmer interface module ignition leads are not loose; replace pcb if necessary.
<b>F7</b>	Flame detected even though appliance switched off.	Check electrode assembly, dry pcb. Flue clear?
<b>FA</b>	Flame detected after gas shut off.	Check gas valve and wiring to gas valve. Clean condensation trap and check electrode assembly. Flue clear?
<b>Fd</b>	Reset button pressed by mistake.	Press reset button again
<b>P1, P2, P3, P1...</b>	Please wait, initialisation in progress.	24 V fuse blown. Replace fuse.

Table 17

## 9.2 Short parts list

Key	Description	Qty GC	Spare part number
1	Sensor - Flue gas temp.	1	8 722 963 858 0
2	Sensor - CH flow temp.	1	8 714 500 087 0
4	Control board	1	8 748 300 498 0
5	Gas valve	1	8 747 003 508 0
6	Fan assembly	1	8 717 204 411 0
8	Expansion vessel	1	8 715 407 260 0
9	Relief valve	1	8 717 401 012 0
10	Electrode assembly	1	8 718 107 087 0
11	Electrode lead	1	8 714 401 999 0
12	Pump	1	8 717 204 384 0
13	Pressure gauge	1	8 717 208 079 0
14	Burner skin seal	1	8 711 004 325 0
15	Transformer - facia	1	8 747 201 358 0
19	Washer set Condensation Trap	1	8 710 103 154 0
20	Fuse set	1	8 744 503 010 0
23	Primary heat exchanger	1	8 715 406 920 0

Table 18

### 9.3 Heating/hot water output settings (N.G)

Display code	Natural gas G20		
	Heat output kW	Heat input kW	Gas vol. flow rate (l/min at $t_V/t_R = 80/60^\circ\text{C}$ )
30			
40			
50			
60			
70			
80			
90			
100			

Table 19

### 9.4 Heating/hot water output settings (L.P.G)

Display code	Propane	
	Heat output kW	Heat input kW
40		
50		
60		
70		
80		
90		
100		

Table 20

## 9.5 Operational Flow diagrams

### 9.5.1 Central heating function

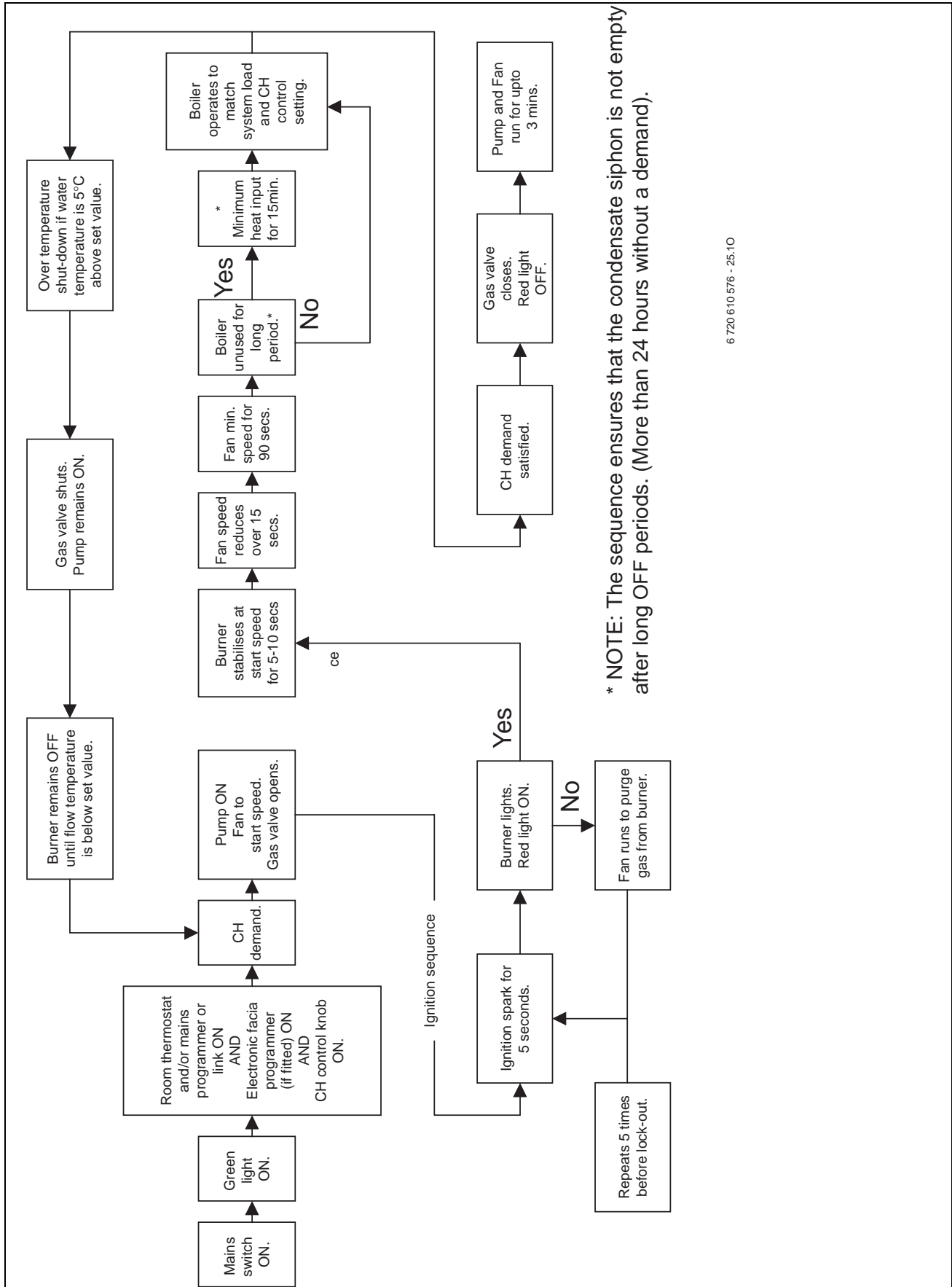

6 720 610 576 - 25.10

Fig. 63



EXCELLENCE COMES AS STANDARD

Worcester Bosch, Cotswold Way, Warndon, Worcester WR4 9SW.

Telephone: (01905) 754624 Fax: (01905) 754619